



# Installation Manual Sample Stream Multiplexer

## ShipCEMS Continuous Emission Measurement System



This page is intentionally left blank!



# Installation Manual

## Sample Stream Multiplexer

*The purpose of this installation manual is to provide the information required to install the Sample Stream Multiplexer for Analyser Systems e.g. ShipCEMS Compact in a safe and efficient manner.*

*This manual is intended for personnel performing the installation. The information supplied shall be used as basis for the installation contractor's own drawings applicable to the ship. On completion of the installation, this manual must be kept on the ship for reference purposes during system maintenance.*

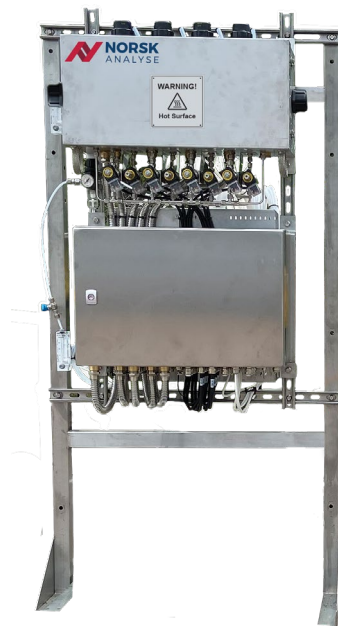

**Revision status**

Revision	Date	Prepared	Checked	Approved
Rev. 01	06.02.2025	ALI	CRA	MBA

**Document history**

Revision	Reason for issue
Rev. 01	First issue.

**Copyright**

© Norsk Analyse

No part of this document may be reproduced, copied, modified, or translated in any form or by any means, without the prior written approval from Norsk Analyse.

**Important**

Before using the equipment, read all instructions thoroughly and follow all precautions and warnings contained within this document. Improper use may cause personal injury and/or damage to the equipment and may void the warranty. Norsk Analyse disclaims any responsibility for damage or injury caused by improper installation, use or maintenance of the equipment.

## Table of contents

<b>1</b>	<b>INTRODUCTION.....</b>	<b>8</b>
1.1	Purpose.....	8
1.2	Scope conditions.....	8
1.3	Contact details.....	9
<b>2</b>	<b>GENERAL SAFETY RULES .....</b>	<b>10</b>
2.1	High voltage.....	10
2.2	Hazardous components.....	10
2.3	Heavy equipment.....	10
<b>3</b>	<b>SYSTEM DESCRIPTION .....</b>	<b>11</b>
3.1	System overview.....	11
3.2	Example of layout.....	13
3.3	Sample and calibration gas flow.....	14
3.4	Power distribution.....	15
3.5	Signal distribution.....	16
<b>4</b>	<b>EQUIPMENT HANDLING .....</b>	<b>17</b>
4.1	Transportation.....	17
4.2	Inspection at receipt.....	18
4.3	Lifting.....	18
4.4	Pre-installation storage.....	19
4.5	Unpacking.....	20
<b>5</b>	<b>TECHNICAL SPECIFICATIONS.....</b>	<b>21</b>
5.1	Environmental requirements.....	21
5.2	Physical dimensions.....	21
5.3	Ingress protection.....	22
5.4	Materials.....	22
5.5	Power supply.....	22
5.6	Power consumption.....	22
5.7	Instrument air.....	23
<b>6</b>	<b>INSTALLATION GUIDELINES .....</b>	<b>24</b>

<b>7</b>	<b>INSTALLATION PROCEDURES .....</b>	<b>25</b>
7.1	Installation sequence.....	25
7.2	Mount the Multiplexer and the junction box, JB2.....	25
7.3	Mount the sample probe .....	27
7.4	Heated sample line, HSL (wet).....	28
7.4.1	Preparation.....	28
7.5	Strip and mark heated sample line .....	31
7.6	Heated sample line connection in the probe .....	36
7.6.1	End termination of tracer cable on probe type 1.....	36
7.6.2	End termination of tracer cable on probe type 2.....	40
7.6.3	Heated sample line connection on probe.....	41
7.6.3.1	Probe type 1.....	42
7.6.3.2	Probe type 2.....	45
7.7	Connect power cables to Multiplexer JB2.....	47
7.8	Heated sample line connection in the Multiplexer.....	49
7.8.1.1	From probe.....	49
7.8.1.2	Between Multiplexer and Analyser cabinet (e.g. SCC).....	62
7.8.1.3	Adding a Multiplexer (Slave) Option.....	69
7.9	Finalising the installation.....	71
7.9.1	Connection.....	71
7.9.2	Field bus specification .....	72
<b>8</b>	<b>INSTALLATION CHECKLIST .....</b>	<b>73</b>
<b>9</b>	<b>REFERENCES .....</b>	<b>77</b>
9.1	Drawings .....	77
9.2	Documents.....	78
<b>10</b>	<b>INSTALLATION OVERVIEW .....</b>	<b>79</b>

## Acronyms and abbreviations

Back-purge	Cleaning of probe by flushing instrument air
CEMS	Continuous Emissions Monitoring System
DWG	Drawing
GA	General Arrangement (Drawing)
HSL	Heated Sample Line
PFA	Perfluoroalkoxy alkane (plastic tube material)
PLC	Programmable Logic Controller
PTFE	Polytetrafluoroethylene (plastic tube material)
SP	Sample probe
SSM	Sample Stream Multiplexer (short: Multiplexer)
SCC	ShipCEMS Compact

## Admonitions

---

<i>Note</i>	<i>Text set off in this manner presents clarifying information or specific instructions relevant to the immediate instruction.</i>
<i>Caution</i>	<i>Text set off in this manner provides a warning notice that failure to follow the directions in this caution can result in damage to equipment.</i>
<b>Warning</b>	<b>Text set off in this manner provides a warning notice that failure to follow the directions in this warning can result in bodily harm or loss of life and/or extensive damage to equipment.</b>
<b>DANGER</b>	<b>TEXT SET OFF IN THIS MANNER PROVIDES A WARNING NOTICE THAT FAILURE TO FOLLOW THE DIRECTIONS IN THIS WARNING WILL RESULT IN BODILY HARM OR LOSS OF LIFE AND/OR EXTENSIVE DAMAGE TO EQUIPMENT.</b>

---

# 1 Introduction

## 1.1 Purpose

The purpose of this installation manual is to provide the information required to install the Sample Stream Multiplexer (hereafter called Multiplexer or SSM) for analyser systems e.g. ShipCEMS Compact in a safe and efficient manner.

This manual is intended for personnel performing the installation. The information supplied shall be used as basis for the installation contractor's own drawings applicable to the ship.

Chapter 7 Installation procedures go through the steps of the installation from mounting the sample probe to internet connection.

On completion of the installation, this manual must be kept on the ship for reference purposes during system maintenance.

In addition to this installation manual, a drawing package is prepared for your system to facilitates installation of power and signal. Request the drawing package or support at: [support@norskanalyse.com](mailto:support@norskanalyse.com)

## 1.2 Scope conditions

The installer performing the installation becomes fully responsible for the ShipCEMS equipment upon receipt unless otherwise stated in the contract. The duration of responsibility includes:

- The time the equipment is stored locally before installation.
- During the entire installation process.
- While commissioning the equipment.
- The time between commissioning and the final acceptance of the equipment by the ship owner.

---

*Note*                      *Prior to installation, check all units for damage as described in the chapter 4.*

*Note*                      *Installation check list needs to be signed and sent to Norsk Analyse in order to obtain warranty of the Multiplexer. Refer to chapter 8.*

---

## 1.3 Contact details

For enquiries related to sales, service, support, maintenance, and spare parts, please contact us at:

Norsk Analyse  
P.O. Box 2313, 3103 Tønsberg, Norway  
[www.shipcems.com](http://www.shipcems.com)

Phone: +47 3337 5100

Fax: +47 3337 5149

Support: [support@norskanalyse.com](mailto:support@norskanalyse.com)

Service: [service@norskanalyse.com](mailto:service@norskanalyse.com)

Spare parts: [marine@norskanalyse.com](mailto:marine@norskanalyse.com)

## 2 General safety rules

Safety precautions must always be followed during installation, operation, and maintenance of the system. Personnel shall be sufficiently qualified, and proper caution shall be taken to avoid injuries or damage to life, health, environment, equipment, and property.

### 2.1 High voltage

---

**Warning**     *The Multiplexer operates at a potentially lethal AC voltage.*

---

Always switch off all power before installation or maintenance. Adhere to safety precautions and instructions as directed by company policy. For safety reasons during troubleshooting on the equipment with power ON, two persons must always be present. Whenever installation or maintenance is carried out, it is essential that a first aid kit is available, and that personnel are familiar with the first aid instructions for electrical shock.

### 2.2 Hazardous components

---

**Warning**     *Many toxic gases are colourless, odourless, and non-irritating, and may overcome exposed persons without notice.*

---

The sample gas may contain trace amounts of hazardous components. Personnel should have a thorough knowledge and understanding of the physical properties and safety precautions for the relevant gas samples before operating the system. Gas inlets and outlets are hot in heated analyser systems. Skin contact may result in serious burns even for a long period after the equipment has been switched off. Make sure the ventilation is good especially if the SCC/SSM is in a small room. Ensure that gas has access to free air.

### 2.3 Heavy equipment

The Multiplexer is a heavy unit. Do not open the lids while in rough seas. Lids may suddenly swing open and cause damage or injury. Use appropriate safety clothing and certified lifting equipment during installation or replacement of larger units!

# 3 System description

## 3.1 System overview

The Multiplexer consists of a

- 1) Hot box (top) which is a sample handling unit
  - Solenoids (middle). Used for calibration and stream switching.
  - Electrical junction box, JB1 (bottom) Control unit with PLC and fuses.
- 2) Heat trace junction box JB2 (upper right corner). Electrical connection points for heated sample lines (HSL).

The main purpose of the Multiplexer (for raw gas applications) is to give multiple streams to a single stream system by stream switching. It provides one sample stream at the time to the analyser system from two to four sample points. Refer to Figure 1. Several Multiplexers can be connected and for each extra Multiplexer there will be three more streams.

The sample from the probe (via a heated sample line, HSL) enters from the top of the Multiplexer through large entry seals. The sample leaving the Multiplexer exits either from the left or the right side, depending on site preferences.

When using the Multiplexer, the sampling time is longer than for only one stream analyser system as there is no fast loop. The Multiplexer is designed for raw gas applications.

The Multiplexer is designed and manufactured for the marine environment; hence ship movements, vibrations and temperature loadings are attended to during design of the system. The sample treatment technology selected is optimised for this specific trace analysis.

The Multiplexer is designed for unmonitored, continuous operation, but all system units may also be manually operated via service PC or the HMI in SCC. The user interface is simple and intuitive, with a limited number of operations necessary to use the system.

Old SCC installations can also be equipped with a multiplexer. Refer to illustration below.

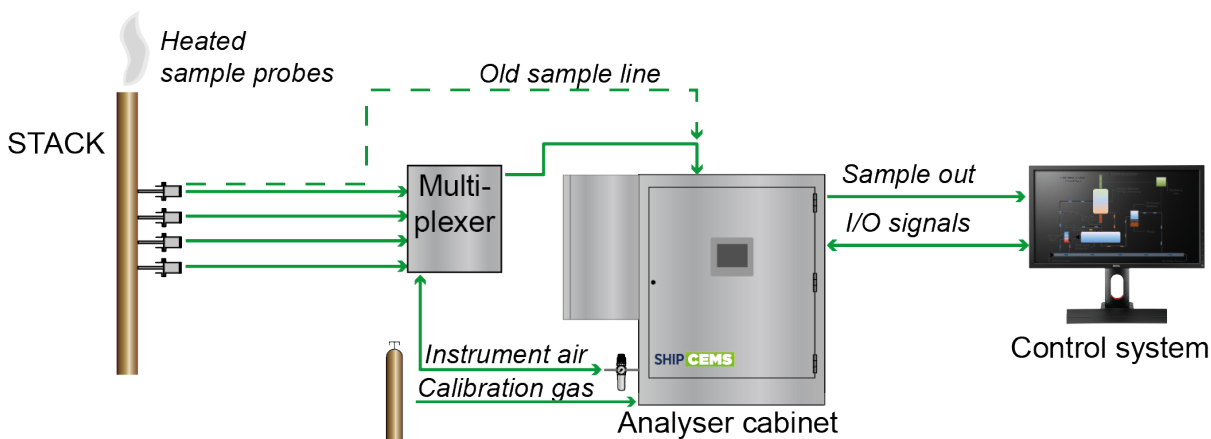

Figure 1 Block diagram for analyser system

The Multiplexer consists of the following main units:

- Multiplexer cabinet
- Multiplexer heat trace junction box
- Wire rope dampers on Unistrut (incl. fasteners)

Optional available equipment:

- Air filter station
- Air dryer unit and mounting kit
- Air compressor

External tubing and electrical interface cables as well as instrument air to be provided by the installer.

---

*Note*                      *Equipment provided locally by the installation contractor or by local dealers is not described in this manual.*

---

### 3.2 Example of layout

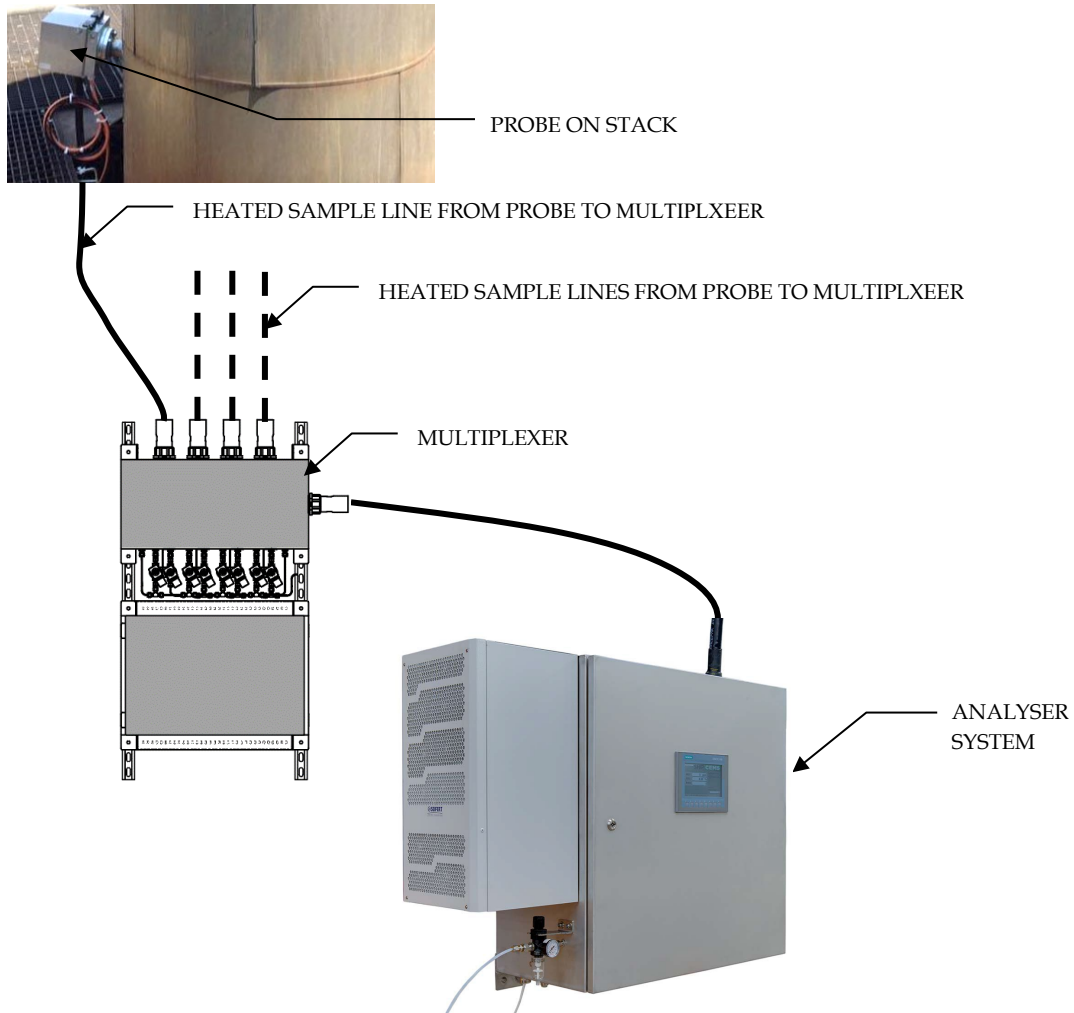

Figure 2 Analyser system with multiplexer

### 3.3 Sample and calibration gas flow

Instrument air supply is provided by the ship. The tube is provided and installed by the installation contractor (refer to A in Figure 3 and to utility requirements ShipCEMS). Calibration gas is only connected to SCC.

**Warning** *D: Outlet gas and calibration gas from SMM needs to be vented to free air. If SMM is installed in a small room, the outlet gas level will increase unless it is vented. For personal safety, ensure the outlet gas has access to free air.*

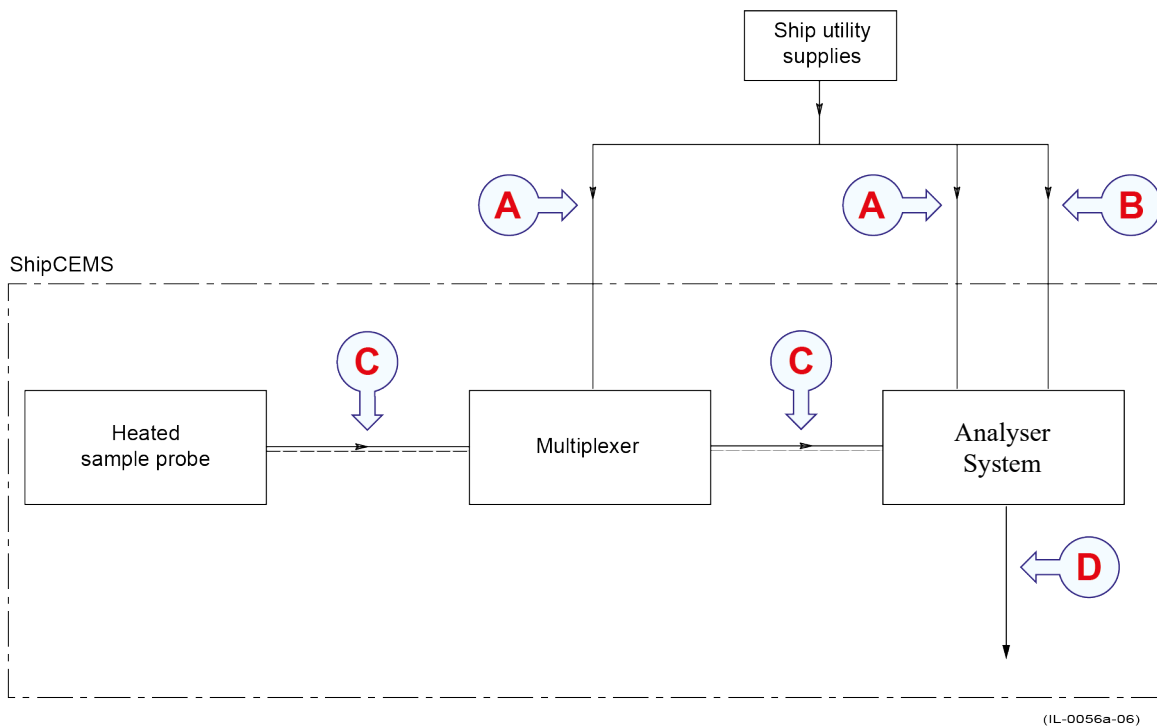

Figure 3 Block diagram – sample and calibration gas flow

- A: Instrument air supply, 10 mm o.d. tube, SS316 compression tube fitting
- B: Calibration gas, 6 mm o. d. tube, SS316 compression tube fitting
- C: Heated sample line (wet), 37 mm o. d. PFA/PTFE tube, with calibration gas to Sample probe.
- D: Analyser Atm. vent

### 3.4 Power distribution

The Multiplexer requires continuous power supply 230V, 50/60 Hz to operate (contact Norsk Analyse for 120VAC systems). The minimum requirement for the power feed cables is:

1. 230V: 2 x 10 mm<sup>2</sup> + PE (protective earth)

All system units must be connected to a local On/Off two-pole power switch located within a radius of 1.5 metres. All switches must be provided by the installation contractor.

---

**Warning**     *Use the appropriate circuit breaker in the ship's switchboard and label the breaker with a warning sign informing that installation work is being carried out. Inform installer before connecting the external power.*

---

The circuit breaker label can only be removed after all power and signal interfaces have been connected.

The multiplexer is powered separately from the analyser system e.g. SCC.

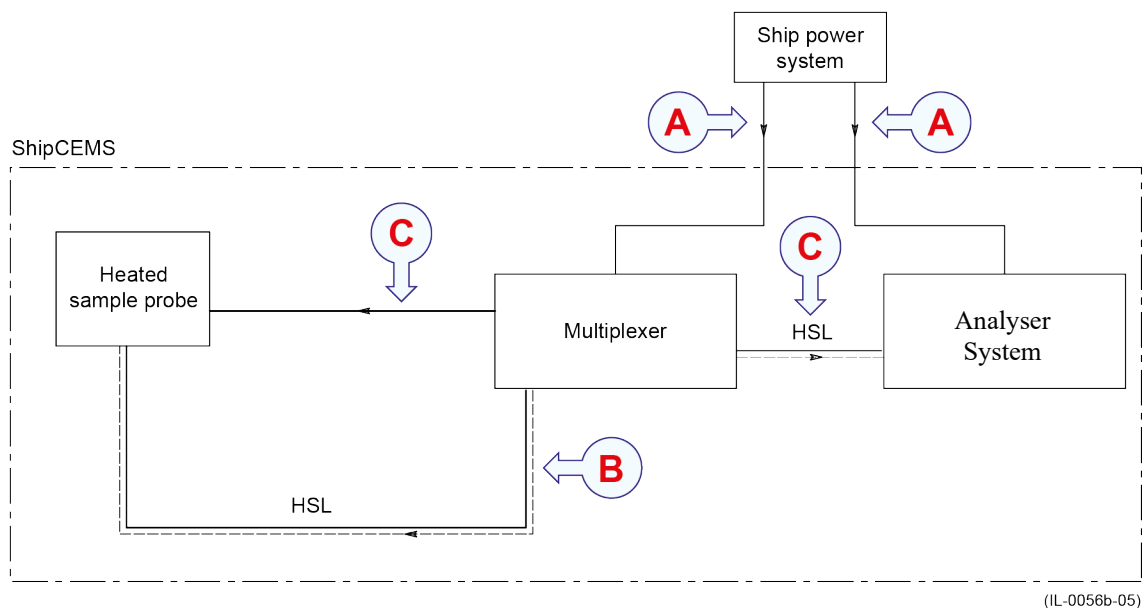

**Figure 4**     Block diagram – power distribution  
 A: Power supply, 2-phase  
 B: Heated sample line from Multiplexer  
 C: Power feed from Multiplexer

### 3.5 Signal distribution

Refer to the following block diagrams for overview:

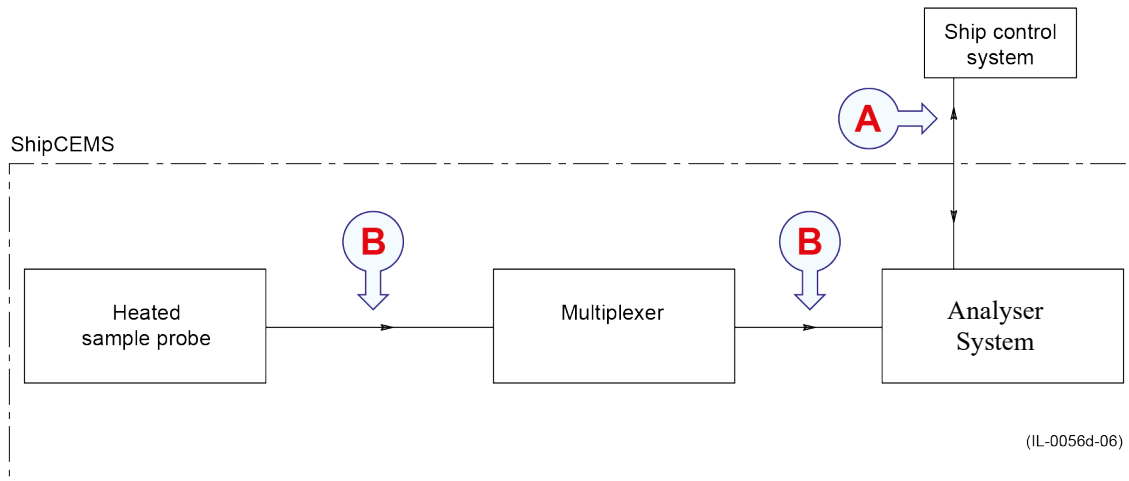

Figure 5 Block diagram – signal distribution  
A: Fieldbus communication  
B: Alarm signal (digital)

# 4 Equipment handling

This chapter describes the equipment handling procedures needed for the installation contractor to evaluate the equipment dispatch and to make plans for receipt, storage, and installation of the equipment.

---

*Note*            *Failure to adhere to instructions given may render the warranty void.*

*Caution*        *During all stages of equipment handling, including installation, use adequate protective covers to shelter the equipment from falling objects from overhead work or similar.*

---

## 4.1 Transportation

Unless otherwise stated in the accompanying documentation, equipment supplied by Norsk Analyse can be transported using all methods approved for fragile equipment. The units must be transported in accordance with general or specific instructions for the appropriate units, using pallets, transport cases or carton boxes as appropriate.

- 1) Always keep the equipment dry and ensure it is sheltered from weather.  
All equipment shall therefore be transported below deck for sea transport, and preferably under a canopy for road transport.
- 2) When equipment is marked with text and symbols indicating which way it is to be placed, follow the instructions given.
- 3) Ensure that ambient conditions, such as temperature and humidity, are always within the equipment's specifications.
- 4) Securely restrain the equipment to avoid mechanical damage and injury to the equipment and to personnel.
- 5) Ensure that the equipment will not be subject to shock, excessive vibrations or other rough handling.
- 6) Handle equipment containing fragile electronic components, such as analyser model, with special care.

## 4.2 Inspection at receipt

A visual inspection must be carried out immediately after the equipment has arrived at its destination to check for any transport or unloading damages.

- 1) Check all pallets, wooden boxes, plastic bags and other packing media for physical damage. Look for signs of dropping, immersion in water or other mishandling.
- 2) If damage is detected externally, open the packaging to check the contents. Request a representative of the carrier to be present while opening, so any transportation damage to single units can be identified.
- 3) If any unit is damaged, prepare an inspection report stating the condition of the unit and actions taken. The report shall be sent promptly to Norsk Analyse.

## 4.3 Lifting

The equipment is heavy approx. 75 kg. Make sure to select the correct lifting equipment before lifting the Multiplexer.

---

**Caution**      *Please handle all equipment with care to avoid damage due to sudden shock or impact.*

---

- 1) The Multiplexer is mounted onto a pallet and can be lifted by a forklift or a pallet truck.
- 2) The Multiplexer is equipped with lifting lugs (Ø15 mm in 4 mm SS316 plate) and can be lifted by a crane or a winch. Refer to the picture to the right.
- 3) The heat trace junction box, JB2 can be removed from pallets by hand.

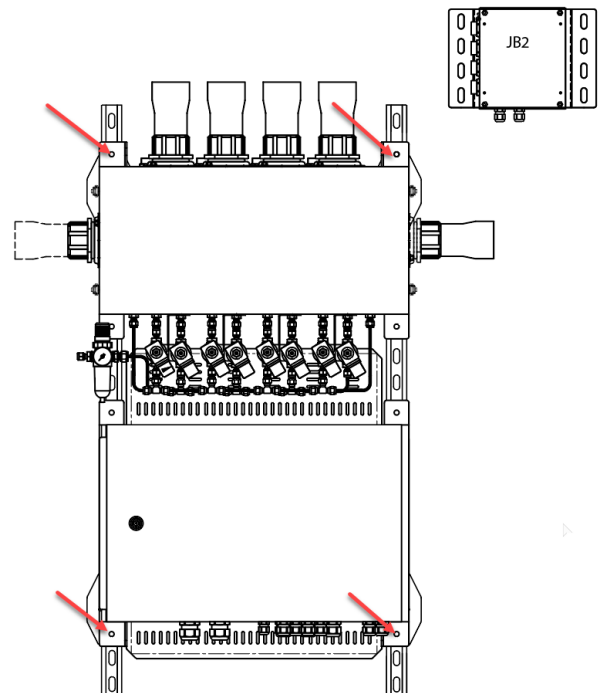

## 4.4 Pre-installation storage

The equipment should be stored in its original transport case until ready for installation. Transport cases must not be used for any purpose for which they were not intended.

It is recommended that the equipment is stored indoors until placed in its intended operating position.

If stored outdoors and exposed to ambient conditions, additional heaters provided by the installation contractor must be used inside the Multiplexer to avoid any vapour to condense in electronic and electrical equipment prior to commissioning and start-up.

- 1) Keep the equipment in a dry, non-condensing atmosphere, free from corrosive agents and isolated from sources of vibration.
- 2) Ensure that the temperature at the storage location is at least +15°C (+59°F) with a relative humidity of 0 to 95 % (non-condensing).
- 3) Carefully unload the Multiplexer onto their foundation or at levelled foundations at the site's storage facilities.
- 4) If stored in a humid environment, ensure that the Multiplexer are heated to avoid failure of built-in sensitive instrumentation, such as analysers. Note that sample probes and similar equipment may be stored in an unheated environment.
- 5) Close all doors and other openings to prevent ingress of dust, dirt and moisture.
- 6) Always lock the Multiplexer to prevent unauthorised personnel accessing the equipment.

## 4.5 Unpacking

Normal precautions must be undertaken during unpacking to prevent damage to equipment or to personnel.

It is recommended to store equipment (unless equipment is prepared for immediate use) in its original packing.

Equipment must be installed in its intended operating position as soon as possible after unpacking.

- 1) Place the transport case to be unpacked on the floor or on a stable work bench.
- 2) When equipment is marked with text and symbols indicating which way it is to be placed, follow the instructions given.

---

**Caution**      *Use certified lifting equipment when handling heavy units.*

**Caution**      *Be careful when working with pallets and wooden boxes. The metal edges of such units may be sharp.*

---

- 3) Check the transport case for signs of dropping, immersion in water or other mishandling.
- 4) Open the transport case using appropriate tools. Open the case carefully to ensure the contents are not damaged.

---

**Caution**      *If a wooden box has been closed using screws, always remove them using a screwdriver. Do not attempt to force the lid off with a crowbar or similar.*

**Caution**      *Do not use a knife to open cardboard cartons, as the contents may lie close to the surface, and may therefore be damaged by the blade.*

---

- 5) Once the transport case is open, carefully remove all loose packing and insulation material before lifting out and installing the equipment contained.

---

**Caution**      *Tubing and cable must never be used as carrying handles or lifting points.*

---

- 6) Also check the transport case for additional equipment that may have been added to the cradle during packing such as manuals, special tools, door keys etc.

# 5 Technical specifications

## 5.1 Environmental requirements

The Multiplexer is designed to comply with IACS E10 - Test Specification for Type Approval

## 5.2 Physical dimensions

Item	Specification
Multiplexer Cabinet Dimensions (W x D x H) Service area: Weight	700 x 400 x 1200 mm Heated sample line: extra 400 mm on the side of the SSM cabinet (right or left). In front of the cabinet an extra 600 mm is required for opening the lid/ door. To save space, the heat trace junction box is mounted on the upper right corner (same side as the HSL exits the analyser cabinet). Approx 75 kg
Heated sample probe Probe length Quill length Flange diameter Weight	254 mm (10") 500 mm (20") (or other customer specific) 160 mm (DN65 PN6) or 175 mm (JIS flange 10K DN65) (or other customer specific) 10 kg (22 lbs.)
Sample probe counter flange Dimensions	160 mm (DN65 PN6) or 175 mm (JIS flange 10K DN65) (or other customer specific)
Heated sample line (wet) Diameter (OD) Weight	37 mm (1.45") 1.2 kg/ m (0.4 lbs)

## 5.3 Ingress protection

- IP44

## 5.4 Materials

Item	Specification
Multiplexer Cabinet	SS316L
Tubing	PTFE
Fittings	SS316L
Heated sample probe quill	SS316L or Hastelloy
Heated sample probe counter flange	SS316L (or customer specific)

## 5.5 Power supply

Item	Specification
Multiplexer: Power from ship switchboard	230V, 2-phase, 50/60 Hz
Power cable specifications	230V: 2 x 10 mm <sup>2</sup> + PE

## 5.6 Power consumption

Item	Specification
Multiplexer	2100 W
Sample probe	300 W
Heated sample line (wet)	67 W/m (Example 1: one stream á 5m between probe and Multiplexer requires 700 W. Example 2: four streams á 20m between probe and Multiplexer requires 5400 W.)

## 5.7 Instrument air

Item	Specification
Quality	Dry, oil-free according to <b>ISO 8573-1:2010 class [4: 3: 4]:</b> Dew point: $\leq -17^{\circ}\text{C}$ Particles per $\text{m}^3$ (1-5 $\mu\text{m}$ ): $\leq 10$ Total oil: $0.01 \text{ mg}/\text{m}^3$
Consumption	Maximum 10 $\text{NI}/\text{month}$ (0.6 $\text{Nm}^3/\text{month}$ ) @ atmospheric pressure
Pressure range	6 to 8 barg (90 to 120 psig)
Dew Point	$<+3^{\circ}\text{C}$ @ 8 barg minimum outlet pressure (lower than $-17^{\circ}\text{C}$ @ atmospheric pressure)

## 6 Installation guidelines

The Multiplexer is subject for approvals by classification societies. The approval design and verification are obtained according to the latest IACS E10 revision.

Best practice proven over many years of experience by the installation contractor can be used to implement other installation solutions than what Norsk Analyse recommends. As the installation contractor has the final EMC responsibility, the installation contractor must ensure that the installation complies with classification rules. The classification society may also enforce additional requirements influencing the installation. The installation contractor must ensure that the Multiplexer installation complies with any additional requirement defined by the classification society.

The Multiplexer must be installed by skilled personnel and be supervised by a technician with relevant experience. Recommendations and requirements for installation of main system items are listed in the following.

---

*Note*            *Failure to adhere to instructions given may render the warranty void.*

---

All work must be carried out in accordance with approved drawings. Therefore, prior to installation, the drawing file prepared by Norsk Analyse must be consulted.

---

*Note*            *Detailed plant specific mechanical drawings for the installation must be provided by the installation contractor, or any contractor performing the installation. Norsk Analyse may, on special order, provide assistance to these drawings.*

*Note*            *All physical dimensions in this manual are given in millimetres (metric).*

**Caution**      *Instruments, cables, and other electrical equipment must be protected against mechanical damage during installation.*

---

Observe that the Multiplexer framework structure is of stainless-steel material SS316L. Plan your installation procedures accordingly. Install Multiplexer on reinforced floor/wall or structural beams.

---

**Caution**      *As instruments are sensitive devices, do not weld onto the Multiplexer framework.*

---

If planning to install any Multiplexer units outdoors, weatherproof protection must be provided. Also avoid installing in open areas with heavy winds, sea splash zones and other areas not suitable for service and maintenance activities.

# 7 Installation procedures

The installation procedures are listed in the preferred installation order.

---

*Note*            *The installation procedures are for a new installation of probe, Multiplexer and analyser systems.  
If the Multiplexer is added to an old installation, the probe connection in the analyser systems must be moved to the Multiplexer. Contact Norsk Analyse for more information.*

---

## 7.1 Installation sequence

To install the Multiplexer the following steps must be performed.

- Analyser system e.g. ShipCEMS Compact is installed.  
Refer to analyser installation manual.
- Mount the Multiplexer and the junction box JB2 on the Vessels structural beams.
- Mount the probe and the heated sample line (HSL).
- Mount the HSL to the Multiplexer.
- Mount the HSL to the analyser system e.g. ShipCEMS Compact.

## 7.2 Mount the Multiplexer and the junction box, JB2

Drawing references:

→ [50118-1101] -HOOK-UP LOCATIONS

→ [50118-3101] - SYSTEM DIAGRAM SAMPLE STREAM MULTIPLEXER (SSM)

To avoid vibrations the Multiplexer cabinet is mounted onto wire dampers.

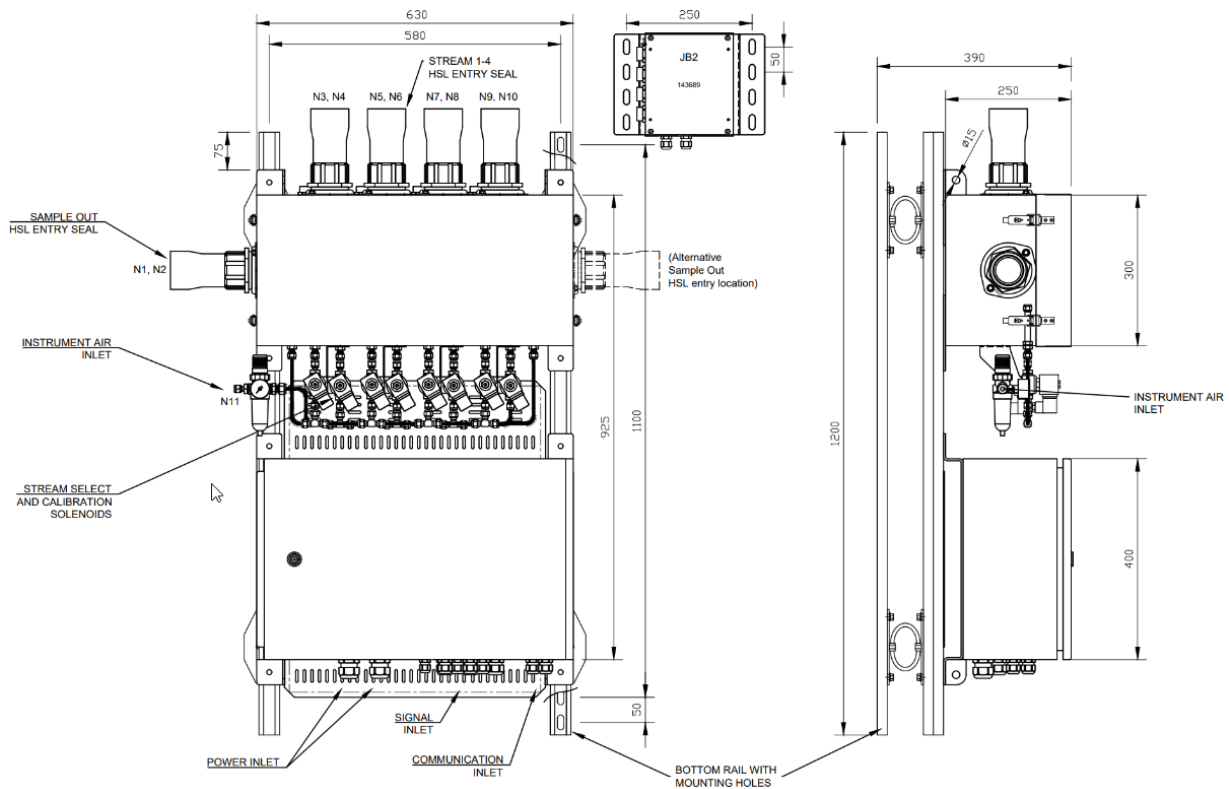

Figure 6 Multiplexer, junction box and anchor rails with dampers, outline dimensions

<p>Installation kit containing nuts for connecting tubing for air supply and sample line connection.</p> <p>Picture shows a set for a 4-stream system (for fewer streams there are fewer nuts).</p>	
---	--

Figure 7 Installation kit located in the Multiplexer electrical junction box JB1

Find a suitable and stable location for the Multiplexer. The Multiplexer must be mounted on ship's structural beams. To ensure maintenance access, make sure that the Multiplexer is installed with adequate spacing in all directions. It is recommended to have 1.0 meters from the mounting wall (minimum 650 mm) to be able to open the hatches when the system is running. On the right-side min. 400 mm and on the left side 400 when HSL to the analyser system is on the left side (otherwise only 150 mm). Above the Multiplexer 400 mm (on top of the box).

**Caution** Do not install the Multiplexer onto the stack!

- 1) Prepare the installation framework (not NAAS supply) by welding steel support for the Multiplexer on the ship's casing.
- 2) Mount Multiplexer to the wall by attaching the two rear anchor rails to the framework. It is recommended to use minimum 6 x M10 bolts (not included) with nuts, three on each of the vertical support frame bars. The upper bolt on each support bar must be mounted above the top wire dampers. The arrangement should be fixed using flat washers and external tooth locks.



---

*Note*                      *The Multiplexer requires instrument air supply to operate. The air supply pressure must be 6 to 8 barg (90 to 120 psig). Air supply is provided by the ship. Refer to technical specifications on instrument air in section 5.7.*

---

- 3) Mount the heat trace junction box on the installation framework on the top right side of the Multiplexer. Mount using 4 x M6-M8 bolts and fender washers (not supplied).

### 7.3 Mount the sample probe

- 4) Refer to Sample probe Operating Manual – Appendix A. for the Multiplexer on the ship's casing.
- 5) Mount the quill on sample probe. Use the small gasket.



- 6) Check inclination on counter flange. The quill should point 5-20° towards the stack.

---

*Note*                      *For installations where water droplets are present at sample point inlet it is recommended to install the probe with inclination 20 degrees.*

---

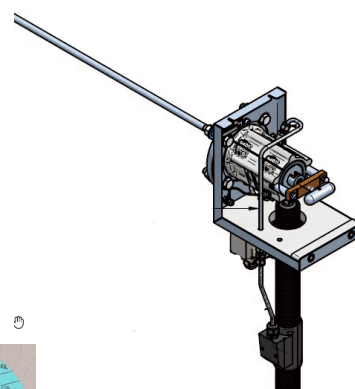

- 7) Mount sample probe on the counter flange (that is welded onto the stack). Use the large gasket.



## 7.4 Heated sample line, HSL (wet)

The heated sample line is supplied on a reel or similar. We recommend that the heated sample line is installed downward towards the Multiplexer and from the Multiplexer downward towards the analyser system unless other options are better suited for the installation. Refer to Figure 6.

The heated sample line must be cut to actual length. Refer to chapter 7.3.1.

Avoid areas where the ambient temperature may exceed +45°C (+113°F).

The heated sample line is an insulated tube bundle consisting of two lines (one for sample, one for calibration) and a tracer cable (heating element). Refer to Figure 8.

The figure below with the electric end termination is connected to the probe. The other end of the heated sample line is connected inside the Multiplexer. Refer to Figure 7.



Figure 8 Heated sample line, HSL to be connected to probe

---

**Caution** *All electrical connections and installations must comply with the requirements of all applicable national and local codes. If there is a conflict between these instructions and the requirements of applicable codes, the requirements of the codes must be followed.*

---

### 7.4.1 Preparation

- 1) Roll out the heated sample line on a flat surface.
- 2) Route the HSL along existing structures such as cable trays and beams to provide enough support.

---

**Caution** *Observe the minimum bending radius of 200 mm when installing the heated sample line to avoid breakage of the internal tubing and heat tracer cable.*

---

- 3) Make sure that there will not be any water traps in the heated sample line.

---

**Caution** *Water trap will interfere with the sample and cause flow alarms! Refer to Figure 7.*

---

- 4) Do not cut heated sample line yet.

- 5) Measure against probe and the Multiplexer. Calculate distance between probe and the Multiplexer + 300 mm for the probe and 1.2 m for the Multiplexer. Mark splicing points on the HSL with tape.

The picture below shows the preferred installations. The red dashed line represents the total heated sample line to be cut. Refer to Figure 7.

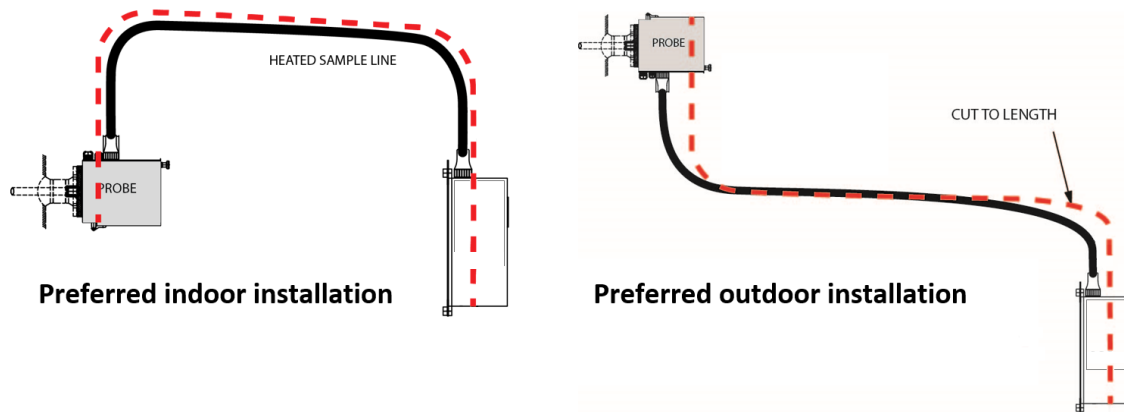

Figure 9 Measure heated sample line length

- 6) Permanently secure the heated sample line using metal clamps. Make sure to use enough support points along the route, typically every meter to avoid water traps. Exception is above the Multiplexer as it must be able to move freely on the wire dampers. It is not recommended to have any rigid support closer than 1.5 meter from entering the Multiplexer. (The HSL can be clamped together as long as they can still move with the system.)
- 7) Cut the heated sample line.

- 8) Find the adapters for flexible conduit. They are in junction box JB2. (The quantity may vary due to configuration.)



- 9) Remove the cap for flexible conduit on top of the Multiplexer and mount the adapter (one adapter per stream to be installed).



- 10) Save the washer and the rubber seal for later installation of the flexible conduit.

## 7.5 Strip and mark heated sample line

---

*Note*            *The tracer cable shall have a length that allows the sample to be heated throughout.*

---

*Caution*            *Take care not to damage the internal tracer cable and sample tube.*

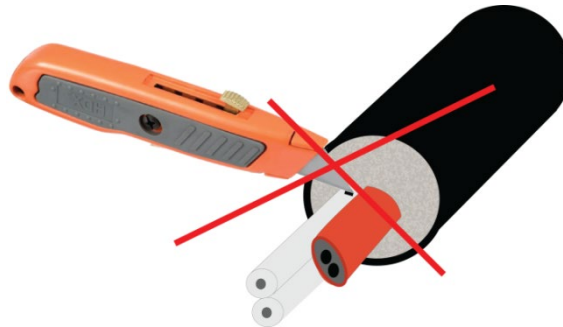

*Caution*            *If the tubes are damaged the whole heated sample line must be replaced.*

---

The tracer cable will be connected to the power in the heat trace junction box.

- 1) Make sure there are no water traps, and that the length is long enough.

*Caution*            *Take care not to damage the internal tracer cable, sample tube and calibration tube.*

---

- 2) **On the probe side:** Strip the heated sample line at the tape mark. Refer to picture below.
- 3) **On the SSM side:** Strip the heated sample line at the tape mark (here yellow).



- 4) Cut the outer black rubber sheet of the HSL using a short knife to not penetrate too deep.



- 5) Once the outer rubber sheet is cut all the way around, bend the HSL slightly to expose the white insulation. Use a longer knife and push it into the insulation with a rocking movement – do not saw! Check regularly when approaching the inner core.



- 6) Bend the HSL in the other direction and repeat the process until the insulation is cut all the way around.

- 7) Pinch firmly at the separation line and pull apart the HSL approx. 10 mm. Make sure the insulation is fully cut all the way through.

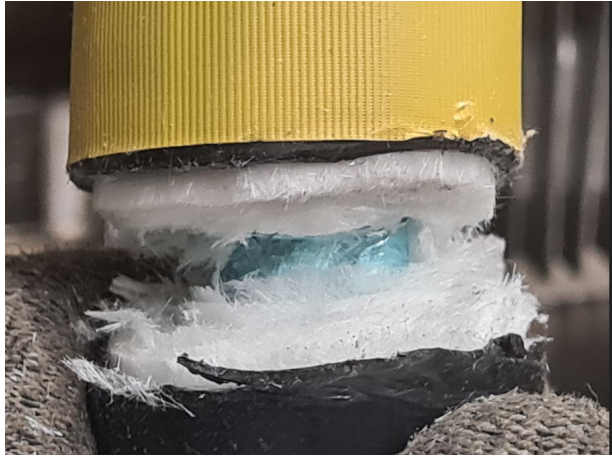

- 8) Pinch firmly at the separation line and pull off the whole black sheet incl. the insulation.

**Caution** *If not pinching at the separation line or if any insulation is not fully cut, when pulling off the outer sheet, the insulation will tighten itself around the core making it impossible to pull off. If this happens the rubber sheet must be cut (lengthwise) all the way and the insulation removed layer by layer.*



- 9) Remove the foil and the tape around the tubing.



- 10) Remove additional 30 mm off the black rubber sheet above the cut to expose the insulation. Use a short knife. If the insulation is expanding a piece of high temperature tape can be used to keep the insulation in place. (tape is not included).

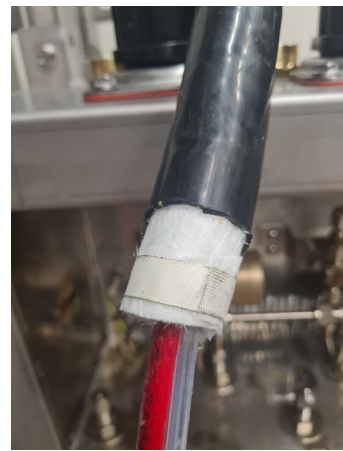
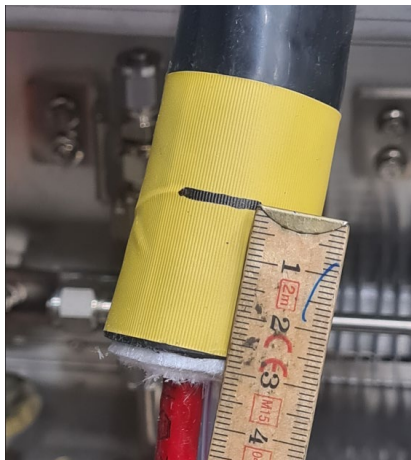

- 11) Select the sample tube and mark it e.g. with a yellow tape. Use compressed air in the calibration tubing to verify the correct tubing on the probe side. Mark the calibration tubing on the probe side as well.

**PROBE SIDE**



**SSM SIDE**

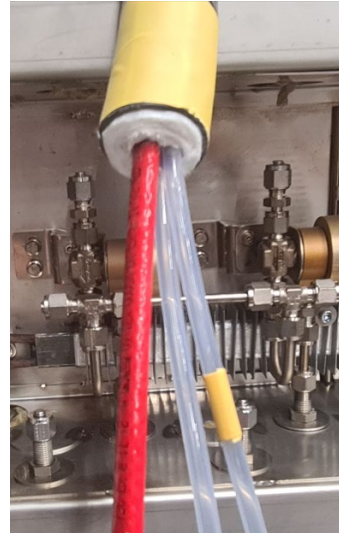

- 12) Tape the ends of the tube to protect them and tape the tubes and the heat tracer together to facilitate installation in the probe/Multiplexer.

## 7.6 Heated sample line connection in the probe

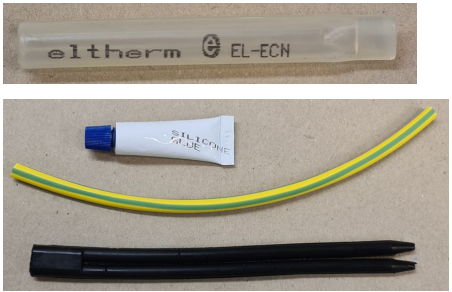
<p><b>Heat trace kit (together with the heated sample line)</b>  <b>Appearance might be different depending on heated sample line.</b></p>	
<p>Heat tracer end termination</p> <p>Silicon</p> <p>Double sleeve (power connection)</p> <p>PE protection sleeve</p>	 

### 7.6.1 End termination of tracer cable on probe type 1

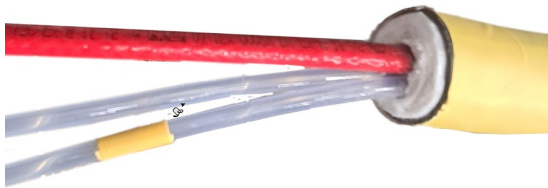
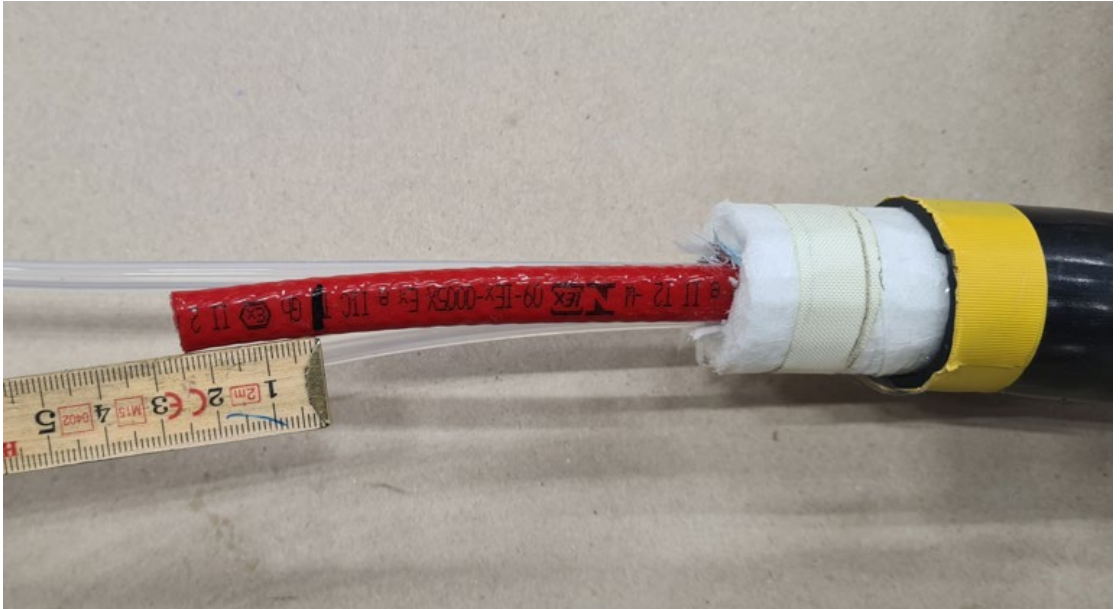

Figure 10 HSL stripped and marked

- 1) Mark cutting location on the heated sample line, minimum 300 mm.



- 2) Splice the end of the heated sample line, incl. the 30 mm extra on the black rubber sheet.
- 3) Perform the end termination of the heat tracer. Shorten the heat trace to 100 mm and mark off 25 mm from the edge.



- 4) Remove the insulation and cut off the shield.



- 5) Make a new mark, 19 mm off the edge and remove insulation.

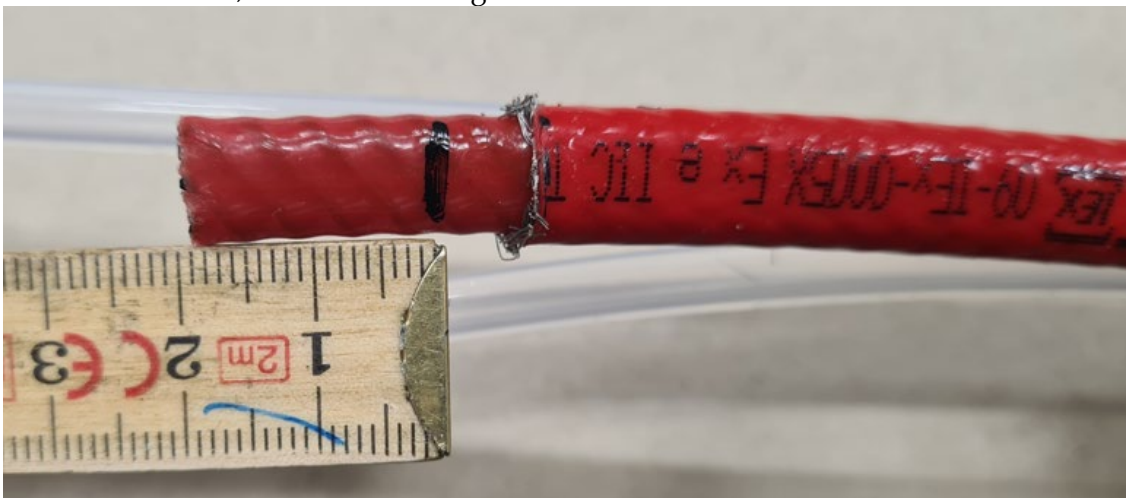

- 6) Cut off the black heat carriers.

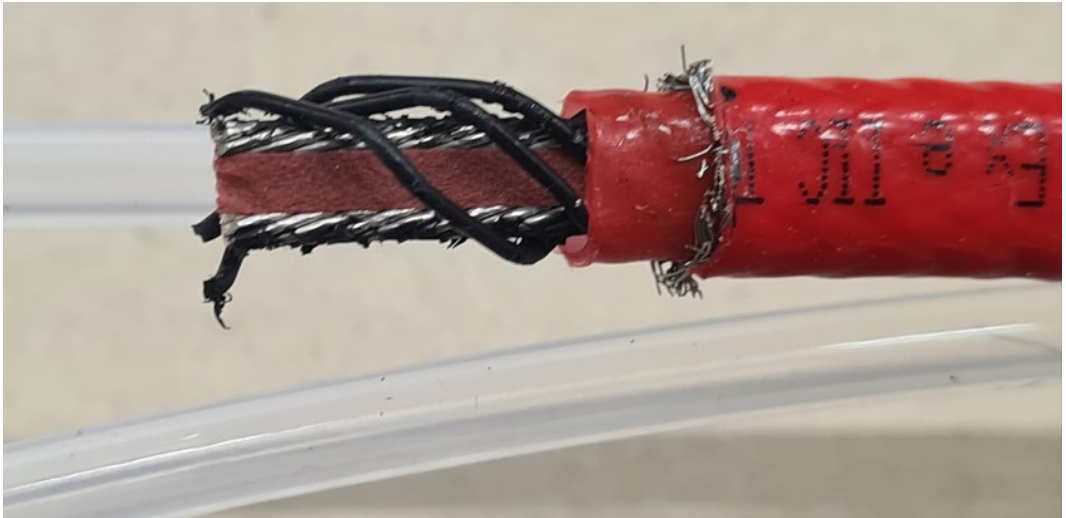

- 7) Cut off one of the power leads as short as possible.

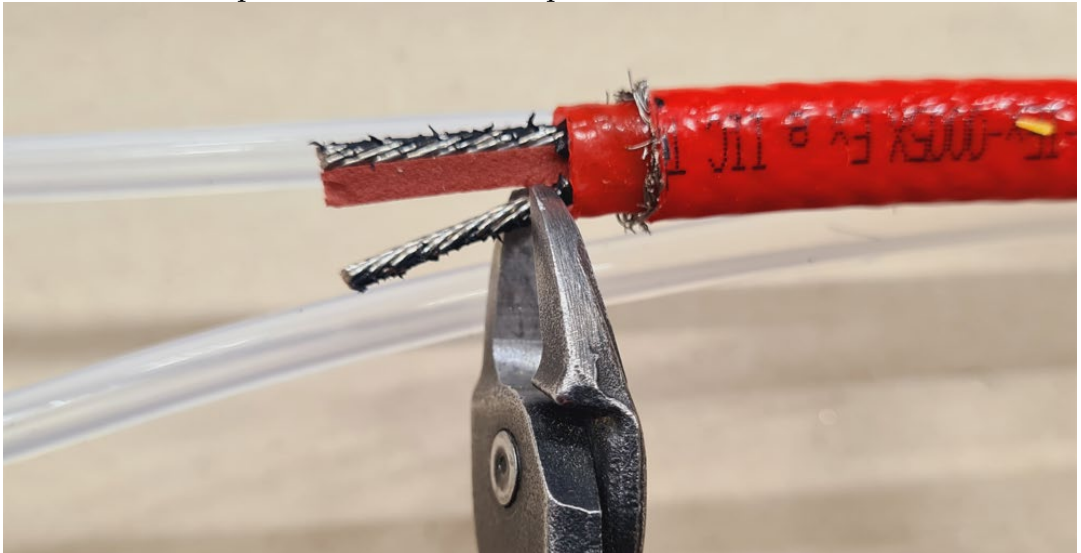

- 8) Shorten the other power lead to half.



- 9) Apply silicone to end cap. Fill it to half and apply silicone to the end of the heat trace.



- 10) Apply silicone to the end of the heat trace and push on the end cap.

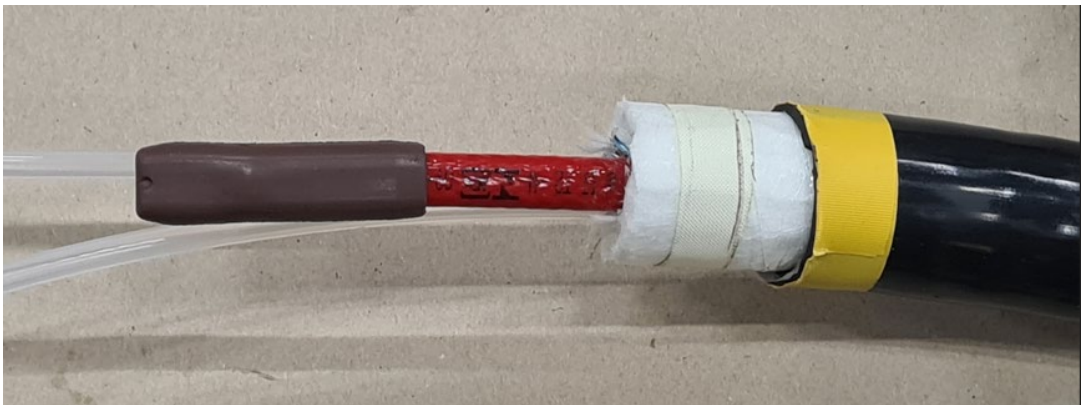

## 7.6.2 End termination of tracer cable on probe type 2

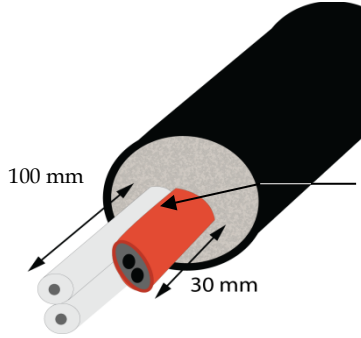
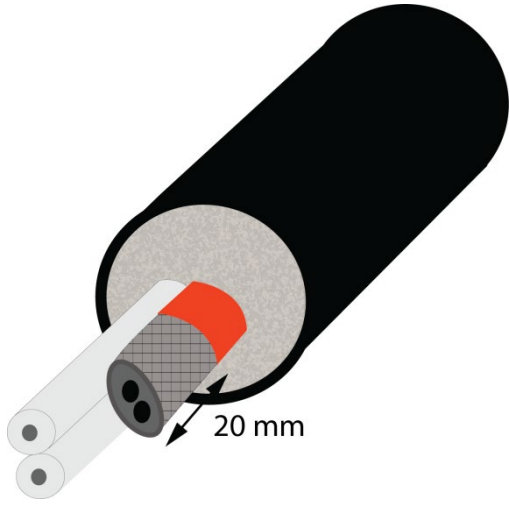
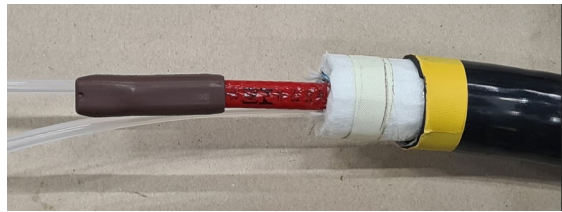
<p>a)</p>	<ul style="list-style-type: none"> <li>• Cut off 100 mm of the heated sample line insulation to expose sample lines and tracer cable.</li> <li>• Cut the heat tracer cable to 30 mm above the insulation</li> <li>• Let the sample lines be 100 mm above insulation.</li> <li>• Make sure there is no contact between electric leaders and shield.</li> </ul>	
<p>b)</p>	<p>Cut off 20 mm of the red insulation to make the screen (metallic threads) visible.</p>	
<p>c)</p>	<p>Perform steps □ in the previous section □ to finish the end termination.</p>	

### 7.6.3 Heated sample line connection on probe



There are different types of probes.

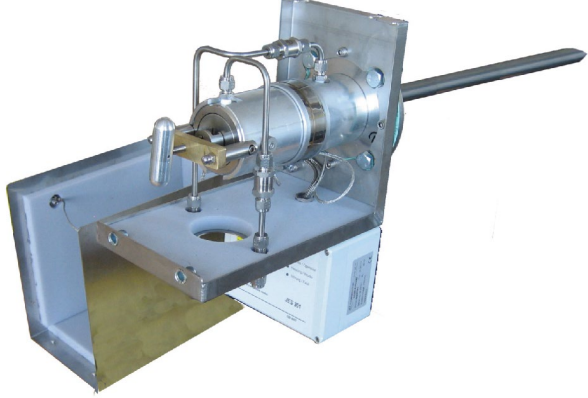
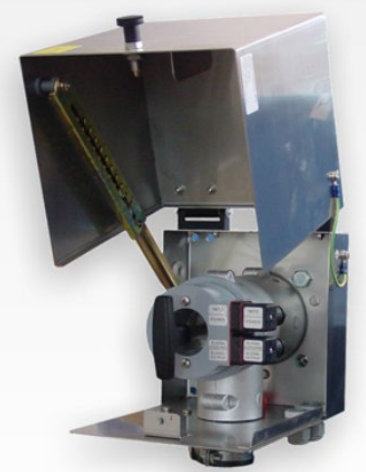

Type 1 use used together with Analyser systems that needs purge e.g. measures Raw Gas when purging is necessary.

For other systems type 2 can be used for e.g. ShipCEMS.

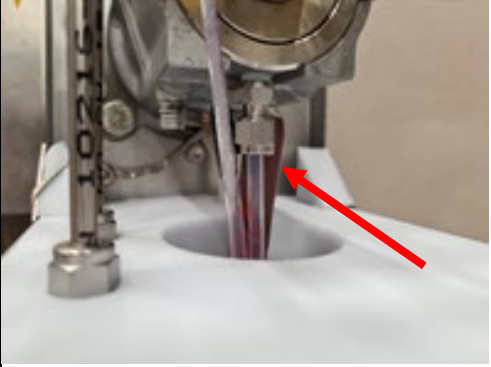
Probe type 1 with purge function	Probe type 2 without purge function
 <p>A photograph of a probe assembly (Type 1) with a purge function. It features a complex arrangement of stainless steel pipes, valves, and a cylindrical component, all mounted on a metal base. A long, thin probe tube extends from the right side. The entire assembly is housed within a partially open metal enclosure.</p>	 <p>A photograph of a probe assembly (Type 2) without a purge function. It shows a more compact design with a stainless steel probe tube extending from a metal housing. The housing is open, revealing the internal components, including a cylindrical sensor or filter unit. The base of the unit is mounted on a small metal platform.</p>

7.6.3.1 Probe type 1

<p>1.</p>	<p>Ready for heated sample line connection.</p>	
<p>2.</p>	<p>Push the heated sample line through the cylinder.</p> <p>From cabinet blow instrument air through the teflon sample line to verify that correct tubing is installed in the probe.</p> <p>While holding the HSL in place, connect the active sample line to the probe.</p> <p>Fasten the active sample line using 14mm or 9/16 open wrench.</p>	  

<p>3.</p>	<p>Mount the calibration line to the calibration nozzle using 14 mm or 9/16 open wrench.</p>	
<p>4.</p>	<p>Mount the first insert and tap it gently inside the cylinder using a small hammer.</p> <p>Mount the second insert, outside the first insert to get it started by hand, but do not push it all the way in. Pushing can cause a kinked sample line inside the probe!</p> <p>When slightly inserted, tap it gently inside the cylinder using a small hammer. Do not overlap gaps.</p>	

Tighten the clamp to hold the HSL in place.



### 7.6.3.2 Probe type 2

The mounting bracket and heat-shrinkable nose are already attached to the probe at delivery. Prior to this procedure, install the analyser cabinet because instrument air is required.

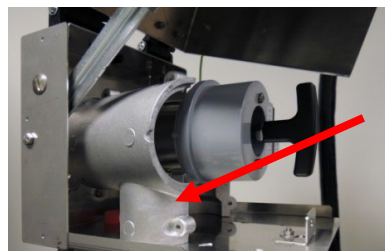
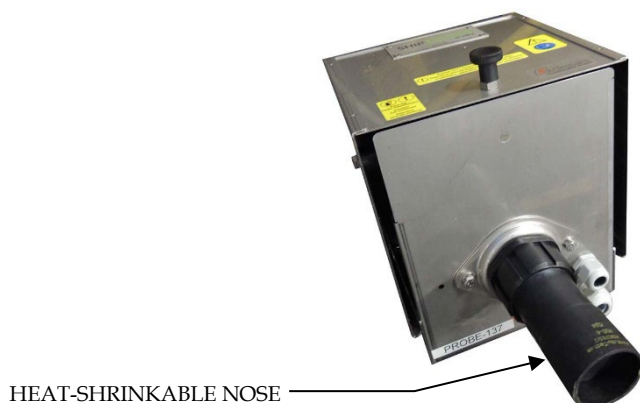
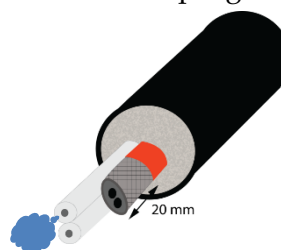

Figure 11 Heat-shrinkable nose

- 1) Remove the plastic cover for connection of the sample line.
- 2) Make sure that the ball valve for instrument air is open. Activate back-purge (analyser cabinet user manual) and check from which sample line the air is coming. This sample line is connected to the probe. The other line will be spare. Inactivate back-purge afterwards.
- 3) Cut the spare sample line to 70 mm and seal it.
- 4) Cut the active sample line to 50 mm.



- 5) Insert the heated sample line into the heat shrinkable nose and connect the sample tube to the sample outlet of the probe using the fitting supplied. Make sure the sample line is pressed correctly into the fitting before tightening with wrench.

Hand-tighten first and then use an open 14 mm wrench to hold the counter nut and another 14 mm wrench to tighten one revolution. Refer to Figure 12 and Figure to the right.

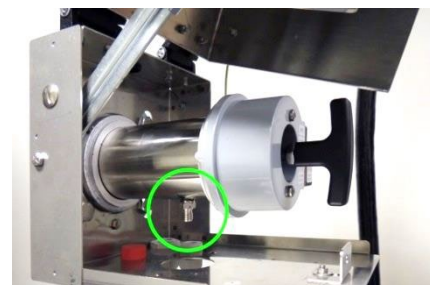

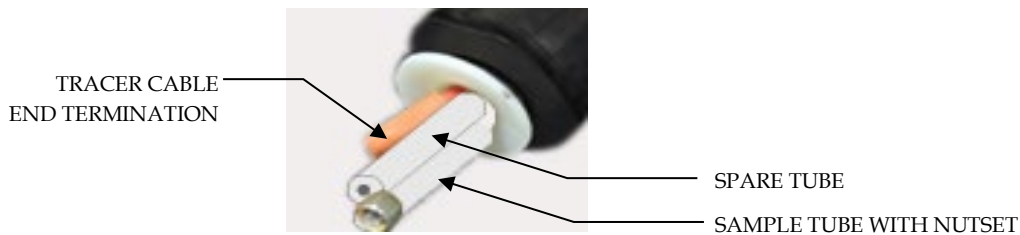
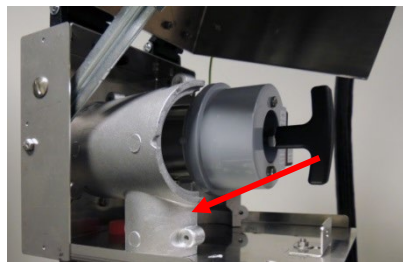

Figure 12 Entry seal assembly including mounting bracket

- 6) Shrink the expanded nose by applying heat with a heat gun. Move the heat gun back and forth to apply heat evenly. Stop heating when the nose has assumed the shape of the heated sample line.

**Caution** Hold the heated sample line approx. 5 minutes while the heat-shrinkable nose and glue sets. Otherwise, the heated sample line will "slide" inside the nose prior to the glue setting, causing the heated sample line to be dislocated. Apply instrument air to speed up the process.

- 7) Fasten the plastic covers, one on each side of the sample probe.



- 8) Cable entrances to the sample probe are through M25 and M20 cable gland at the bottom of the protection shield for the power and signal cables respectively. Connect the power supply cable to the sample probe. The power feed is taken from the adjacent SCS.

Connect the low temperature alarm signal cable at the sample probe end.  
Both interface connections are standard 3-pole DIN plugs.

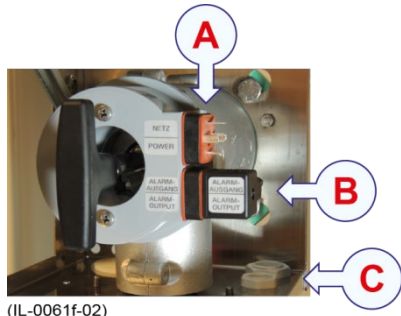
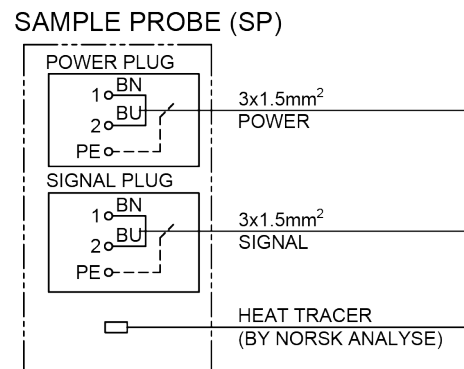

A: Power plug  
B: Alarm signal plug  
C: Cable glands

Figure 13 Heated sample probe, electrical interfaces

## 7.7 Connect power cables to Multiplexer JB2

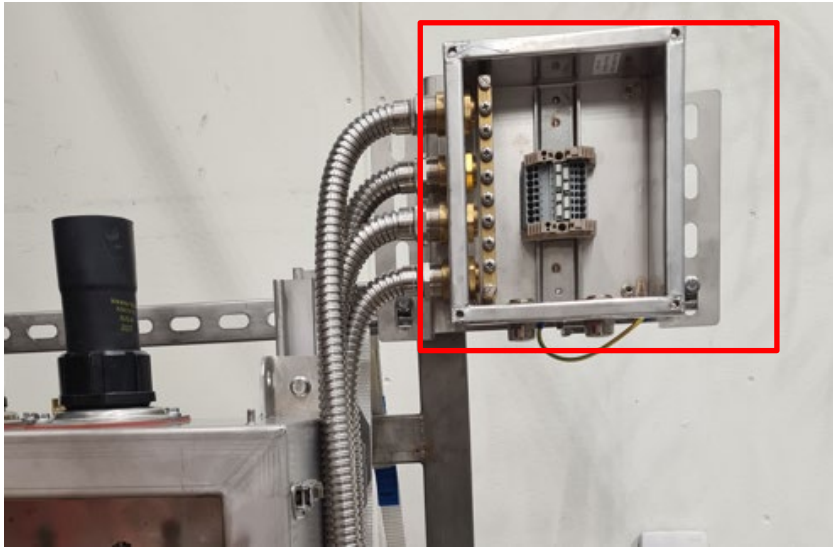

- 1) Mount suitable vertical cable support below the junction box JB2 (not incl. in delivery).

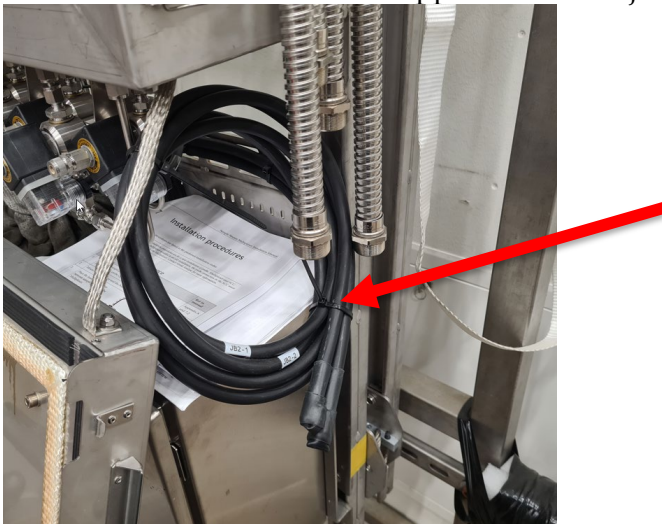

- 2) Unbundle the cables labelled JB2-1 and JB2-2 below the solenoid valves.
- 3) Route the cables to the JB2 box and strap it to the cable support.
- 4) Splice and connect the cables according to terminal drawings 5001, 5002.

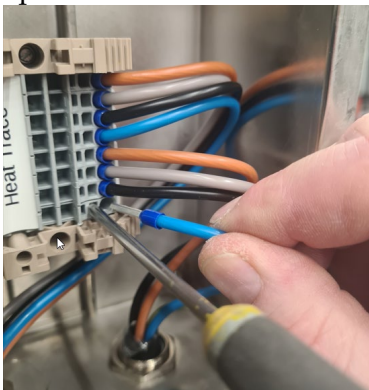

- 5) Mount ring terminals on the PE wires and connect to the PE bar.

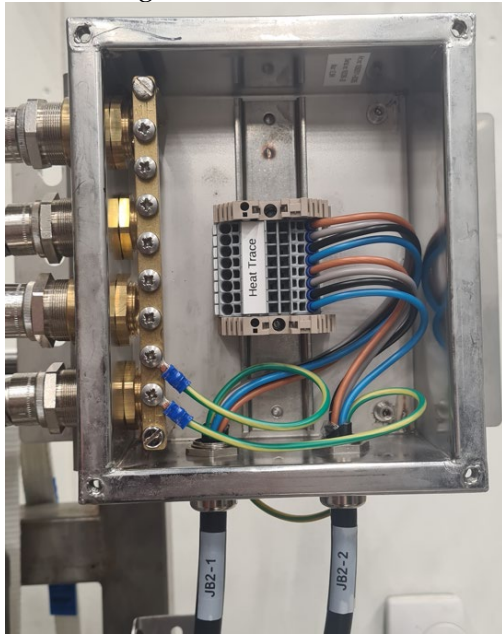

- 6) Mount new cable tags if needed (tags on delivery might not be in optimal location).  
7) In the electrical cabinet JB1:  
Connect the other end of the cables JB2-1 and JB2-2.

---

*Note*                      *Cables are delivered disconnected and isolated for safety.*

---

- 8) Remove the splicing connectors and connect the wires to R21, R22, R23, R24 according to the termination drawing 5001/5002.

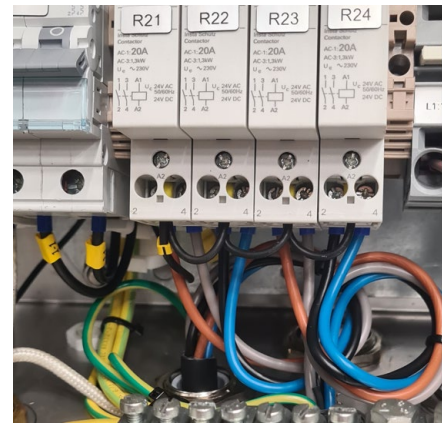
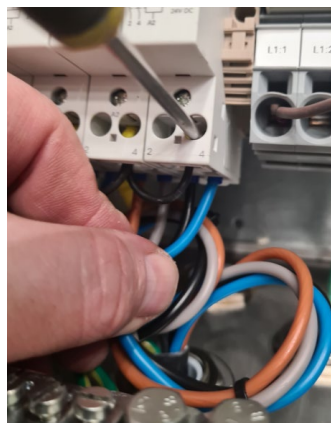
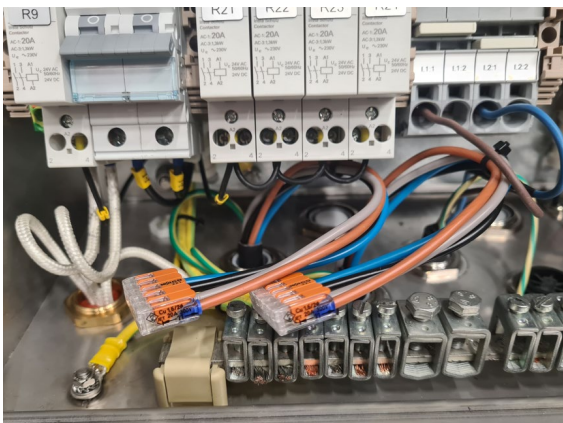

## 7.8 Heated sample line connection in the Multiplexer

### 7.8.1.1 From probe

- 1) Disconnect the entry seal from the top (2 x M6 bolts) and thread it on the HSL.



- 2) Make a hole in the entries with a small screwdriver, just big enough for the hoses and heat trace of the HSL (approx.  $\text{Ø}13 \text{ mm } 1/2''$ ).

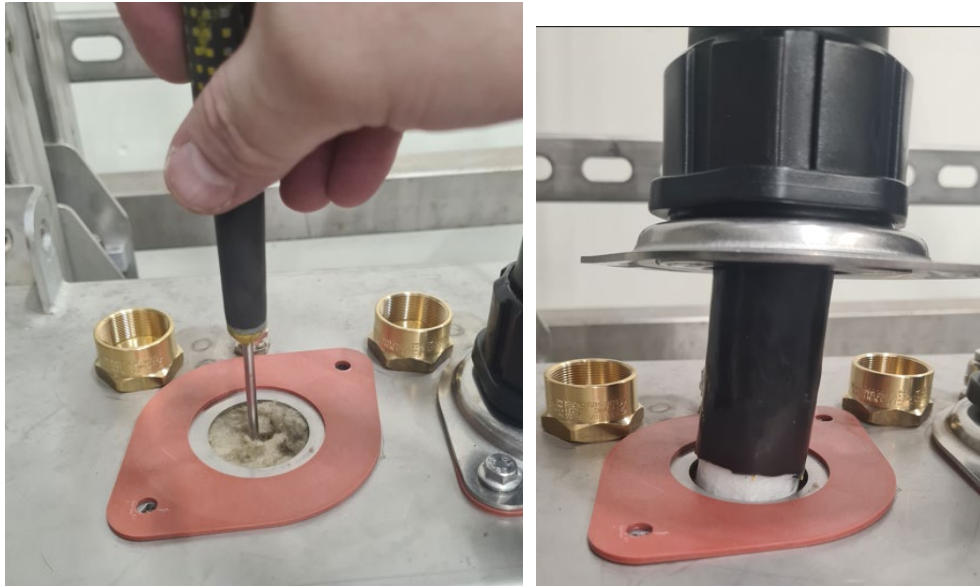

- 3) Insert the tubes and heat trace into the Multiplexer until white insulation is fully inserted in the hole (the black rubber sheet is levelled with the cabinet top).
- 4) Connect the entry seal to the cabinet (2 x M6 bolts). Tighten until the seal protrudes slightly.



- 5)
  - a) Make a hole in the insulation through the conduit adapter for the heat tracer.
  - b) Thread the heat tracer up through the conduit adapter.
  - c) Adjust the heat tracer inside the cabinet to a small bend. Make sure that the heat tracer does not rub against any sharp edges.

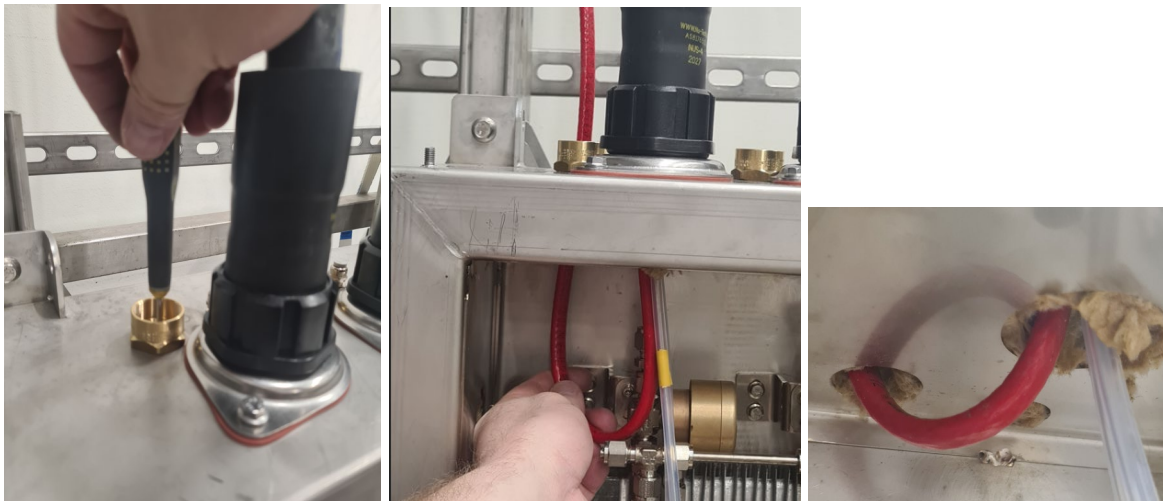

- 6) Mount the rubber seal and the washer into the conduit adapter. Push below the threads.



- 7) Disconnect the flexible conduit from the JB2 box. Save the washer and the rubber seal for later installation of the flexible conduit.

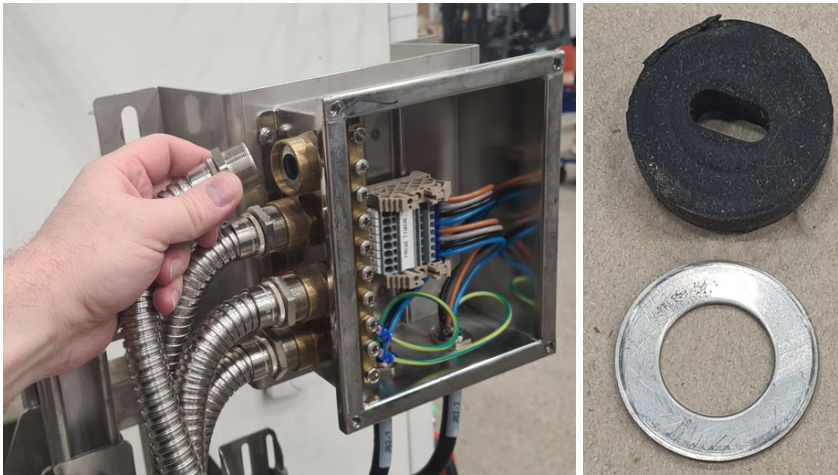

- 8) Thread the flexible conduit over the heat tracer and fasten the flexible conduit in the adapter and tighten with a spanner. Note that approx. 3-4 mm of the threads are visible.



- 9) Adjust the bend of the flexible conduit by holding the end of the conduit at the side of the junction box and pulling/pushing the heat tracer in or out. There must be a minimum of 240

mm of the heat tracer.

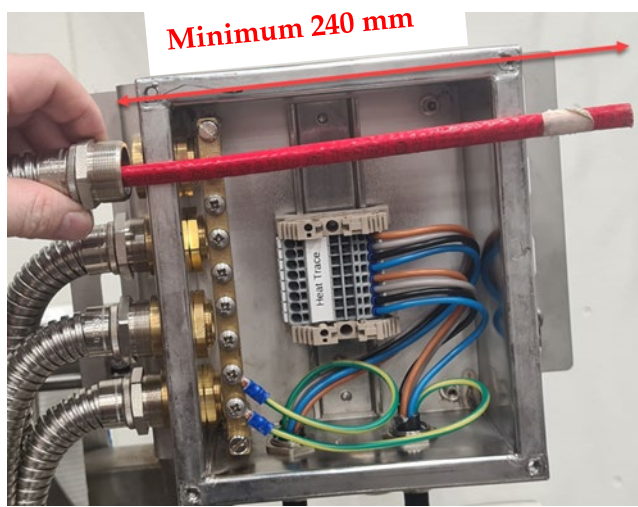

10) Mount the rubber seal and the washer onto the heat tracer.





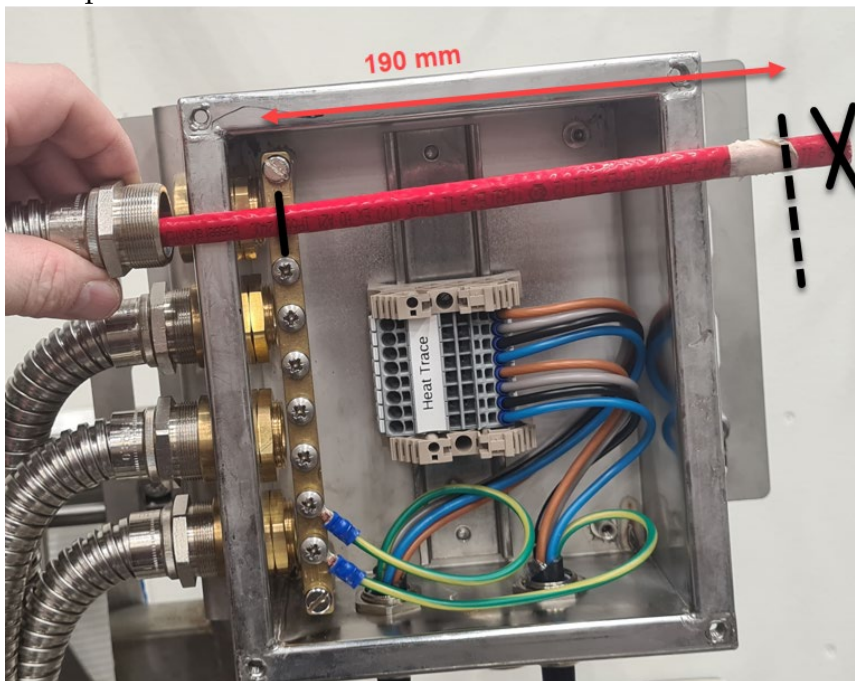

11) Use a pen and mark the heat tracer 30-40 mm from the conduit adapter.

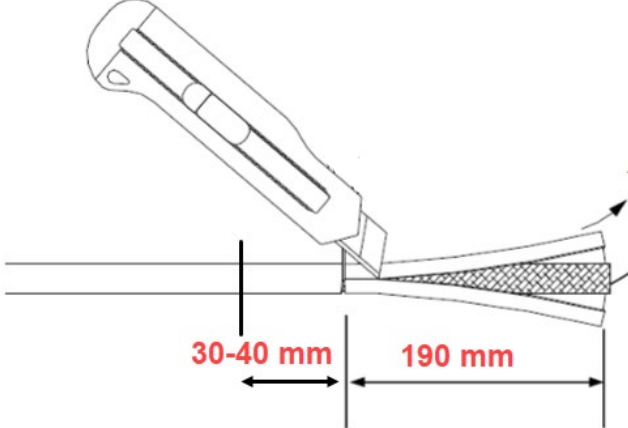

12) From that mark measure 190 mm and cut off the excess.

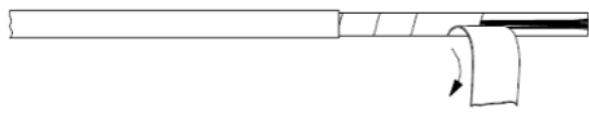
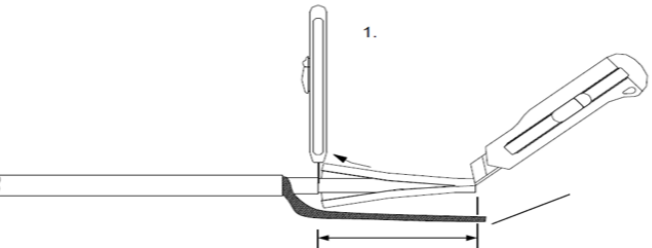
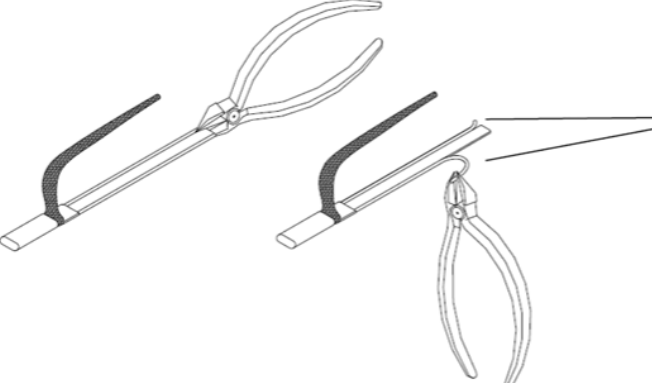
13) Heat trace termination kit is included with the heat tracer.

<p>a) Cut the outer insulation of the heat tracer, approx. 150 mm from the mark.</p>	
<p>b) Expand the braid and pull heat tracer cable through.</p>	
<p>c) Remove foil.</p>	
<p>d) Straighten braid/wire. Do not twist!</p>	
<p>e) Carefully expose the wires.</p>	

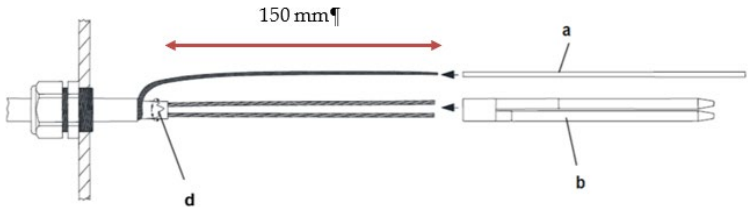
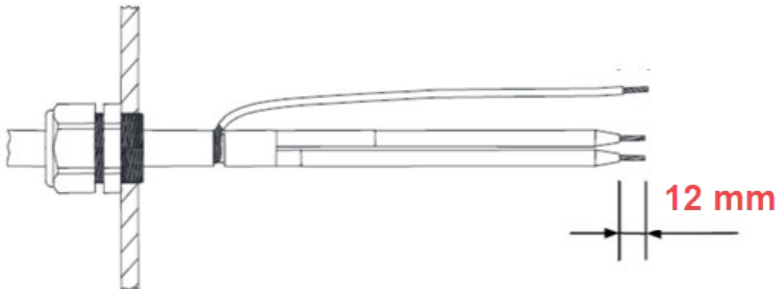
<p>f) Add silicon to the sleeves and carefully thread the PE sleeve and the double heat tracer sleeve.</p> <p>g) Leave the cables until the silicon is set.</p>	 
<p><i>Note</i> The colour of the sleeves can vary depending on brand.</p>	
<p>h) Let the wires protrude 12 mm.</p> <p>i) Remove any insulation from the protruding wires.</p>	

- 14) When the heat tracer end termination is on, attach the flexible conduit incl. the rubber seal and the washer to the junction box JB2 using a spanner. (3-4 mm of the threads are visible.)

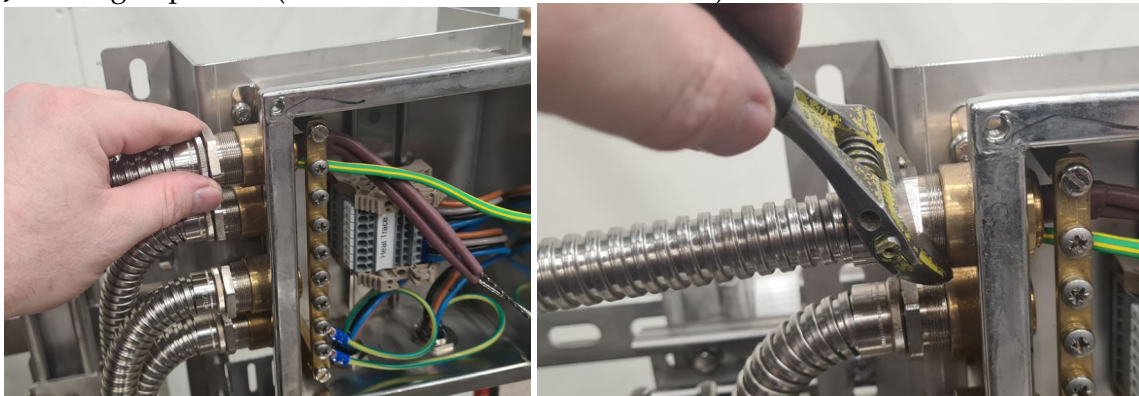

- 15) Attach an insulated or un-insulated ring terminal, 6 mm<sup>2</sup> - M5 (not incl.) to the PE wire and connect it to the PE bar.

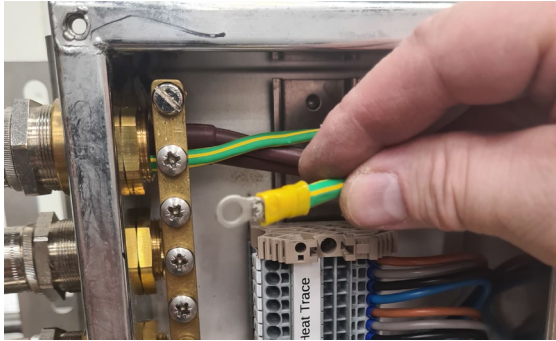

- 16) Shorten the un-insulated wires to 10 mm. Connect them to corresponding terminals. Refer to installation drawing 5001/5002.

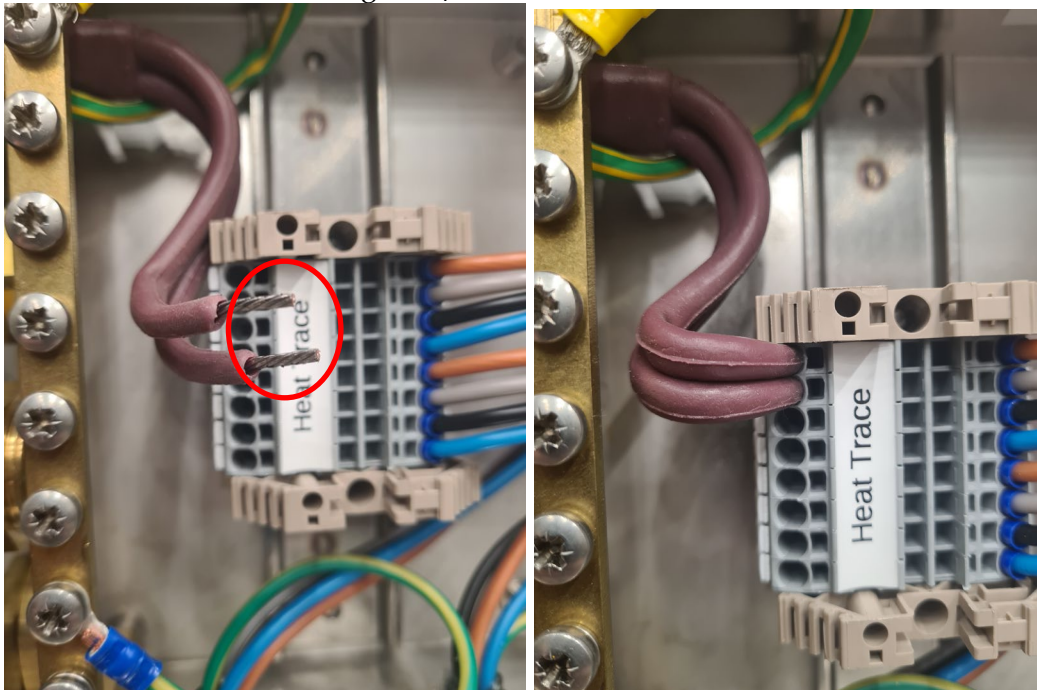

17) Locate sample inlet nozzle N3, N5, N7, N9.

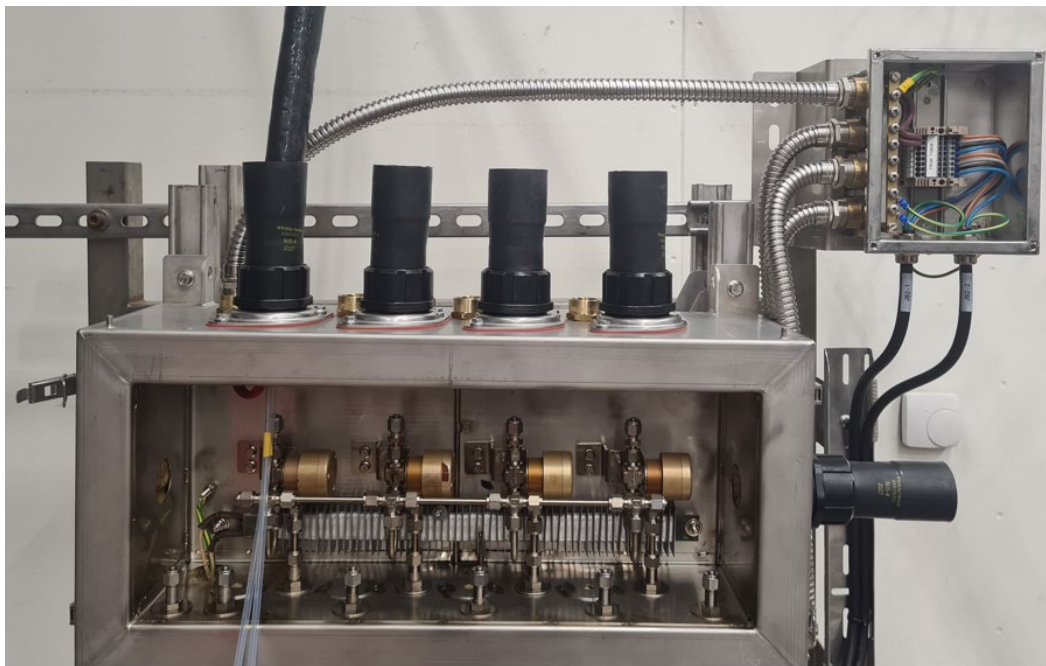
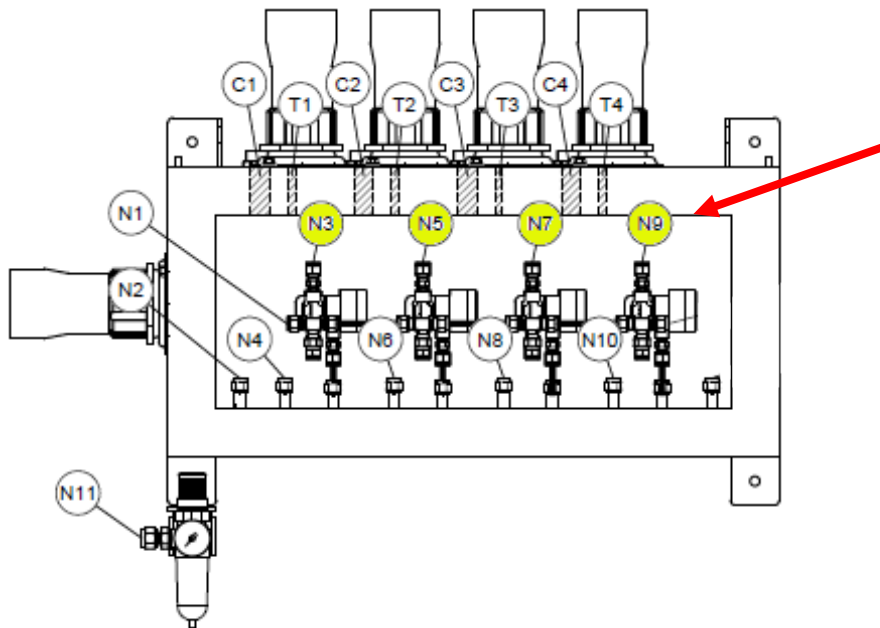

- 18) Place the marked 6 mm **sample** tube at the connection point N3. Use a marker and draw a line 3 mm below the cap. Always cut longer than needed and then adjust.

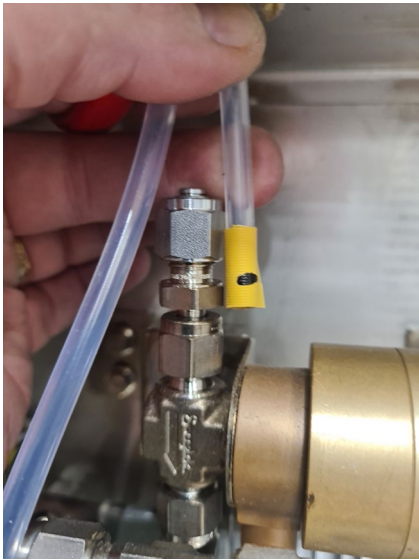

- 19) When tube is adjusted to correct length, remove dust cap from the fitting and mount nuts and ferrules (fasteners are in the JB1 box) to the tube. Make sure the ferrules are in right order and orientation.

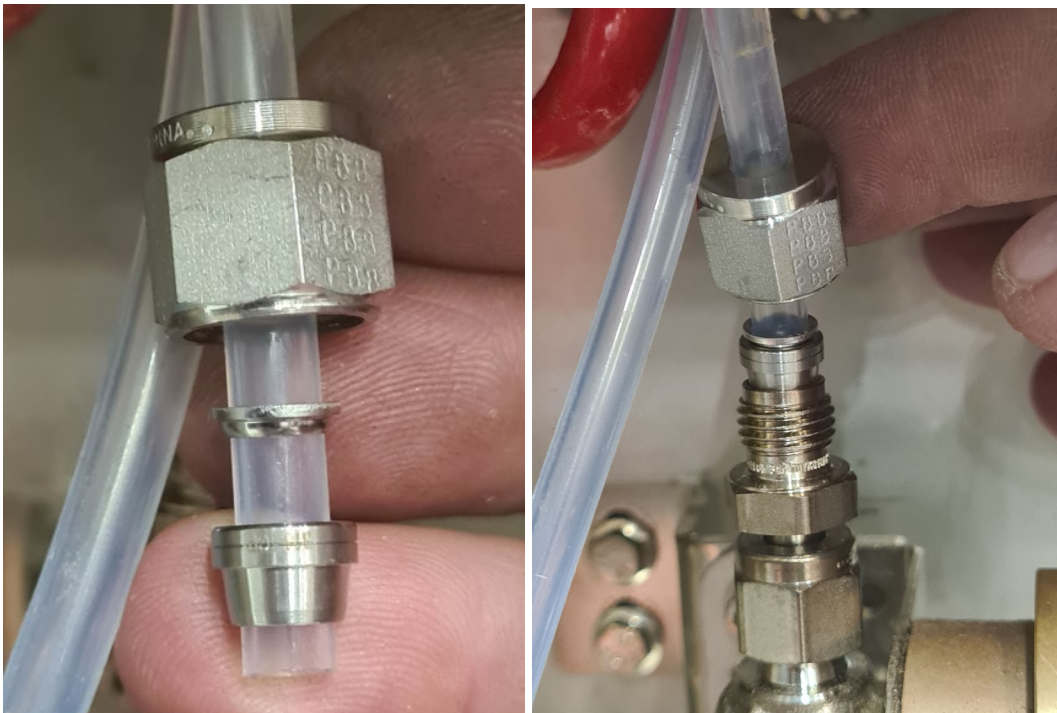

- 20) Hand tighten the nut and then use spanners to tighten the nut 1 ¼ turn.  
(Tip! Mark the nut to count the turns.)



- 21) Locate calibration nozzle N4, N6, N8, N10.

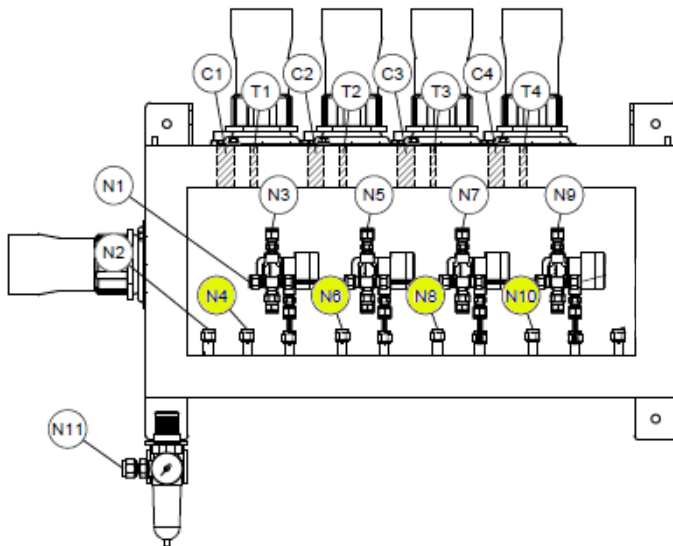

- 22) Place the unmarked 6 mm **calibration** tube at the connection point N4. Use a marker and draw a line 3 mm below the cap. Always cut longer than needed and then adjust.

Mount nuts and ferrules like with the sample line and tighten finally with spanners.



- 23) Sample line and calibration lines are connected.

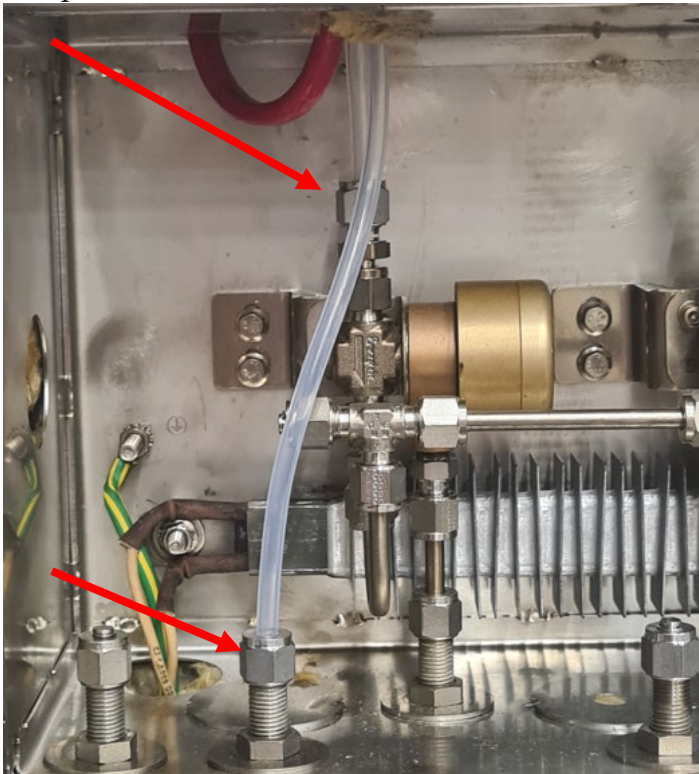

- 24) Before using the heat gun, inspect the insulation in the top of the multiplexer. Add more insulation if needed (e.g. rockwool or glass fibre wool min. 200°C) (not included).



- 25) Shrink the expanded nose by applying heat with a heat gun. Move the heat gun back and forth to apply heat evenly. Stop heating when the nose has assumed the shape of the heated sample line and glue has started to squeeze out of the joints.

---

**Caution** *Hold the heated sample line approx. 5 minutes while the heat-shrinkable nose and glue sets. Otherwise, the heated sample line will "slide" inside the nose prior to the glue setting, causing the heated sample line to be dislocated. Apply instrument air to speed up the process.*

---



- 26) Repeat the steps 7.3 to 7.8.1.1 for the installation of the remaining sample streams.
- 27) Strap the flexible conduits according to picture. They must be able to move and may not be installed to the bulkhead.

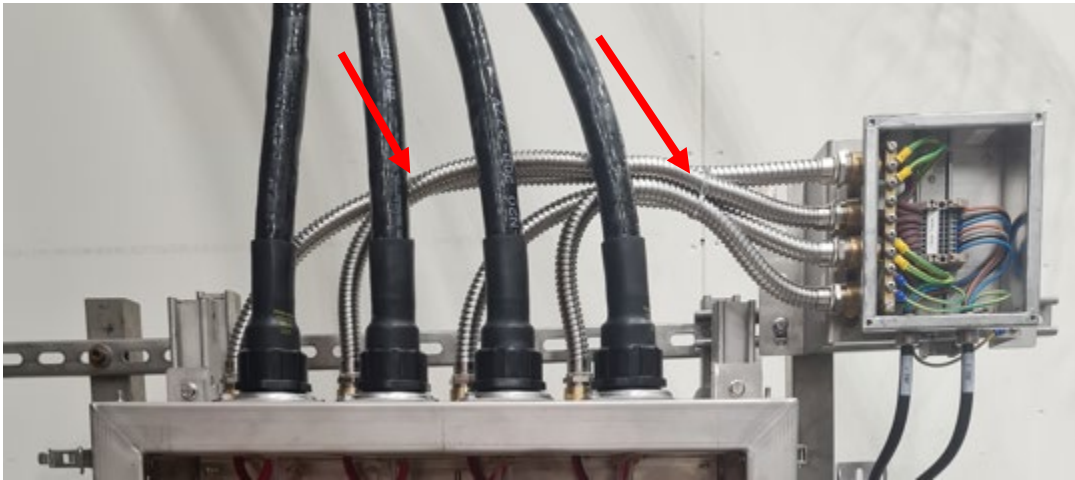

### 7.8.1.2 Between Multiplexer and Analyser cabinet (e.g. SCC)

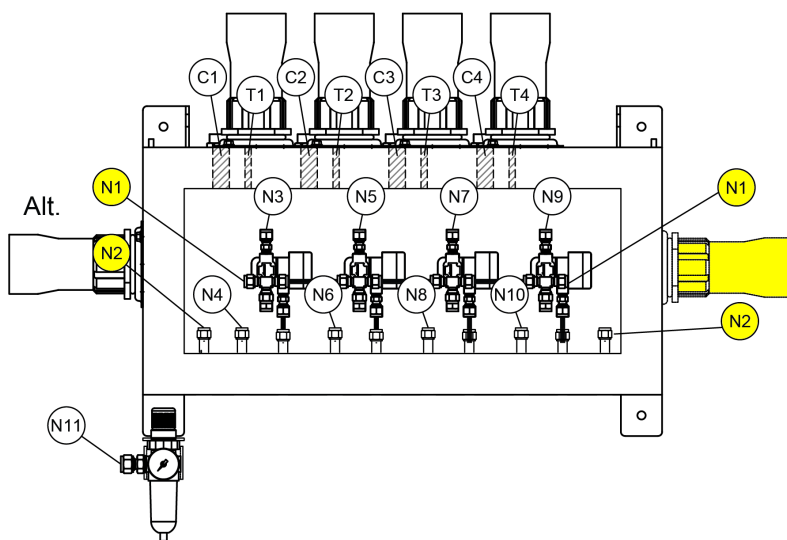

- 1) Locate Sample rail nozzle N1, and calibration connection N2.
- 2) Connect the heated sample line from the analyser cabinet to the Multiplexer left or right side depending on access. Make sure there is no water traps.

- 3) Mark cutting location on the heated sample line, minimum 300 mm.

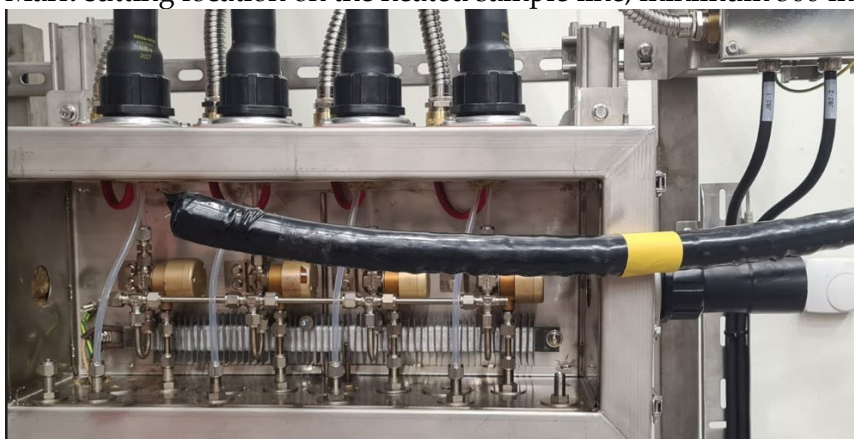

---

*Note*                    *The entry seal can also be mounted on the left side. The pictures below show right side.*

---

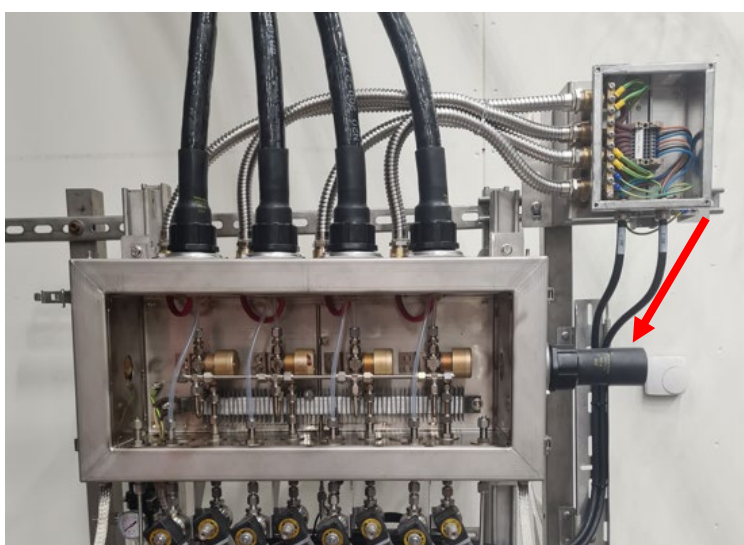

- 4) Splice the end of the heated sample line, incl. the 30 mm extra on the black rubber sheet.

- 5) Perform the end termination of the heat tracer. Shorten the heat trace to 100 mm and mark off 25 mm from the edge.



- 6) Remove the insulation and cut off the shield.



- 7) Make a new mark, 19 mm off the edge and remove insulation.

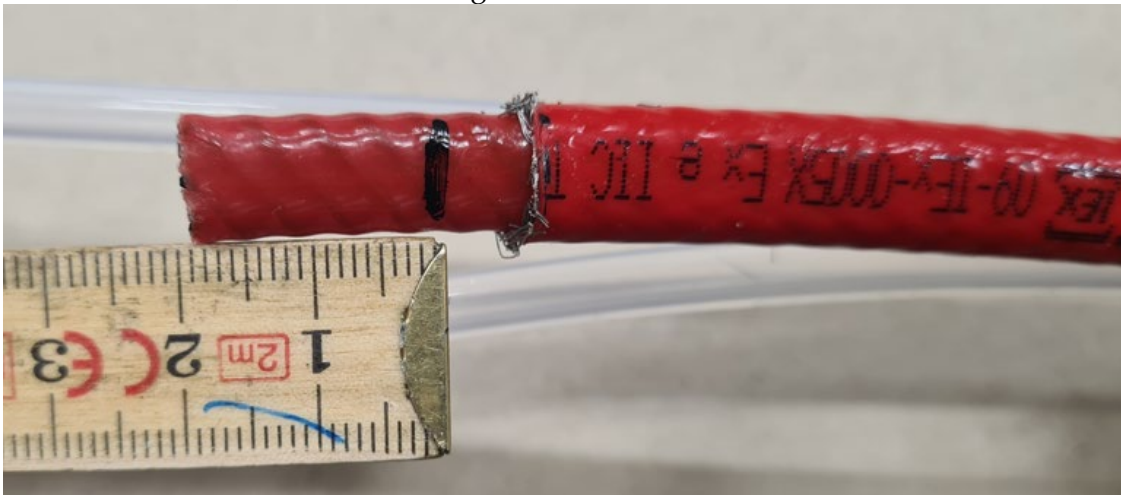

- 8) Cut off the black heat carriers.

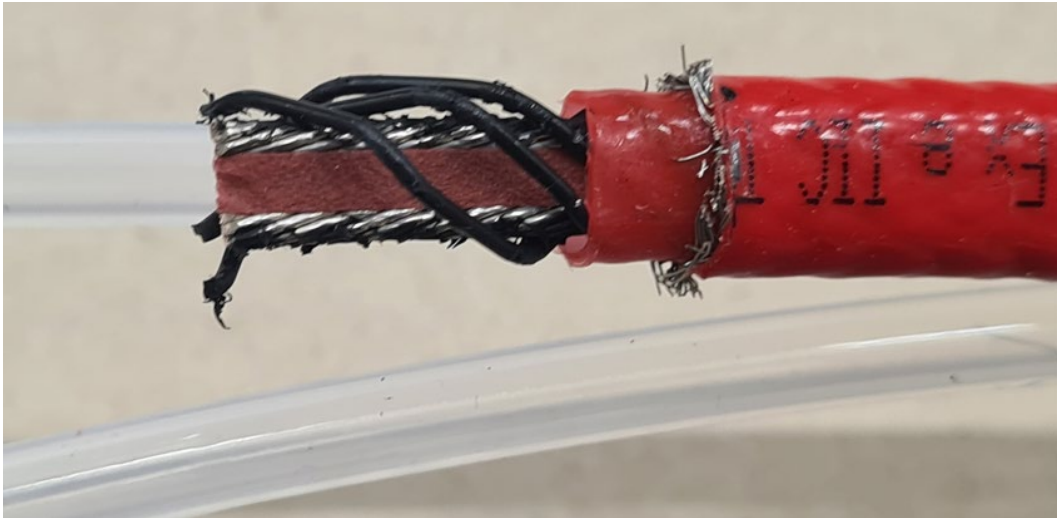

- 9) Cut off one of the power leads as short as possible.

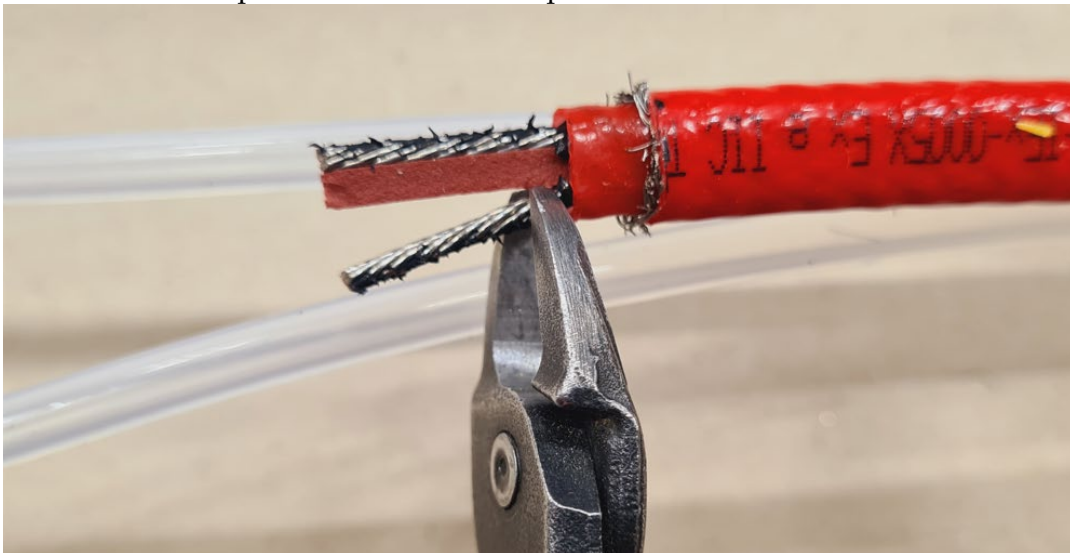

- 10) Shorten the other power lead to half.



- 11) Apply silicone to end cap. Fill it to half and apply silicone to the end of the heat trace.



- 12) Apply silicone to the end of the heat trace and push on the end cap.

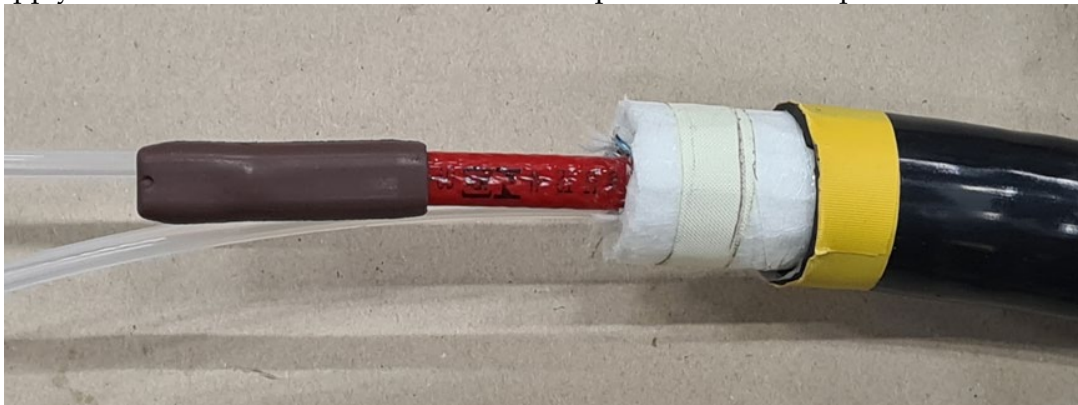

- 13) Disconnect the entry seal on the side (2 x M6 bolts) and thread it on the HSL.
- 14) Make a hole in the entries with a small screwdriver, just big enough for the hoses and heat trace of the HSL (approx. Ø13 mm 1/2"). (For the following three steps also refer to section 7.3 for illustrations.)
- 15) Insert the tubes and heat trace into the Multiplexer until white insulation is fully inserted in the hole (the black rubber sheet is levelled with the cabinet side).

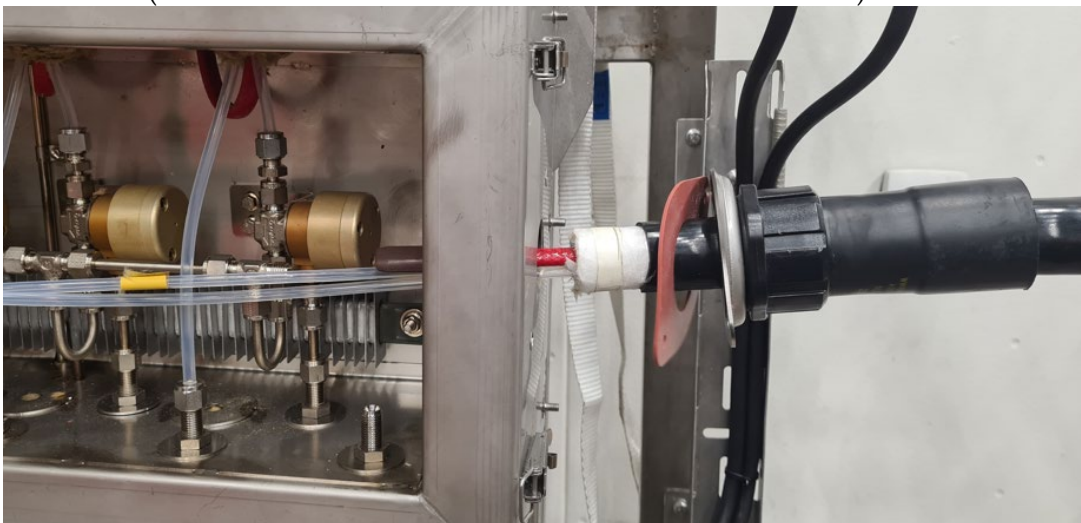

---

**Caution**      *Protect the end cap while inserting the heated sample line.  
The silicon is not set, and the end cap can fall off.*

---

- 16) Connect the entry seal to the cabinet (2 x M6 bolts). Tighten until the seal protrudes slightly.
- 17) When connected to the multiplexer, use compressed air to determine which tube from the analyser cabinet is the sample tube. Mark it with a tape.

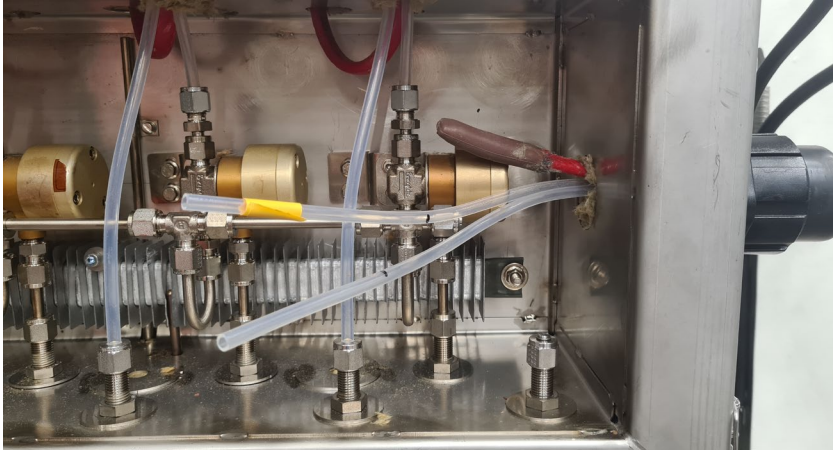

- 18) Take the unmarked tube and mark off cutting location N2. Remove dust cap and ferrules and tighten 1 ¼ turns.

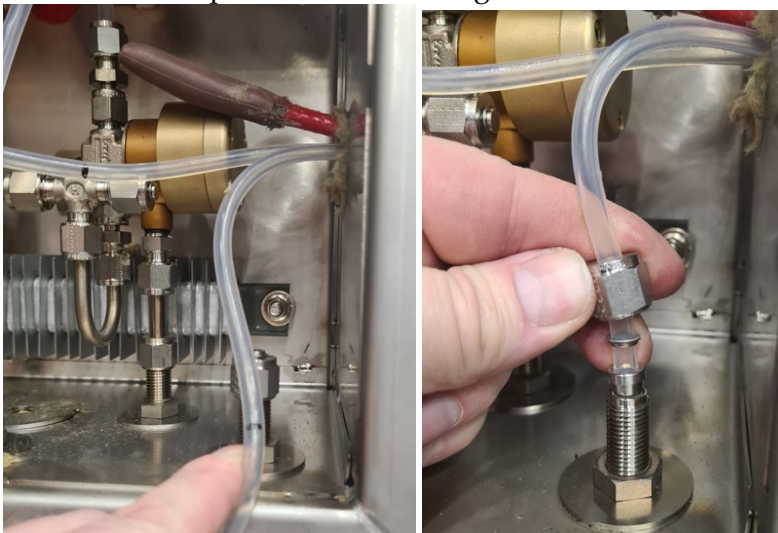

- 19) Take the marked sample tube and mark off cutting location N1. Remove dust cap and mount ferrules and tighten 1 ¼ turns.

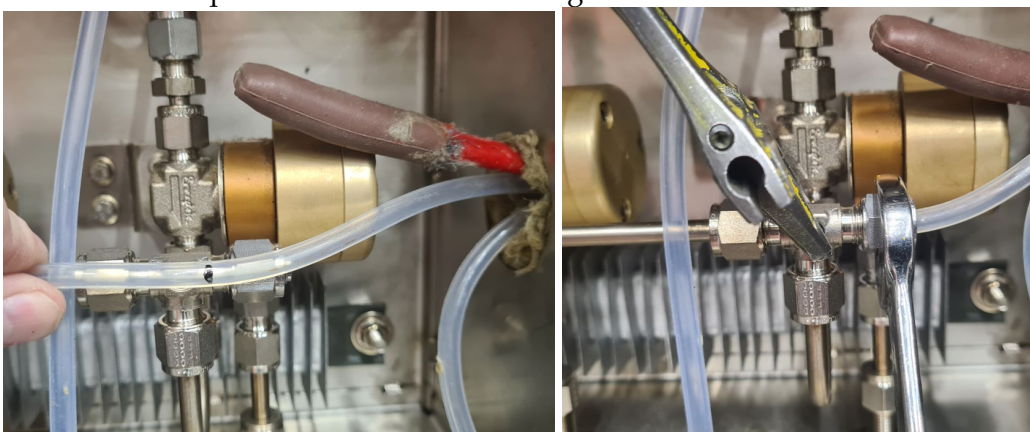

- 20) Make sure that all tubing, heat trace and end termination have distance to the heater as the radiant heat can be very high during start up. End termination must be free hanging.

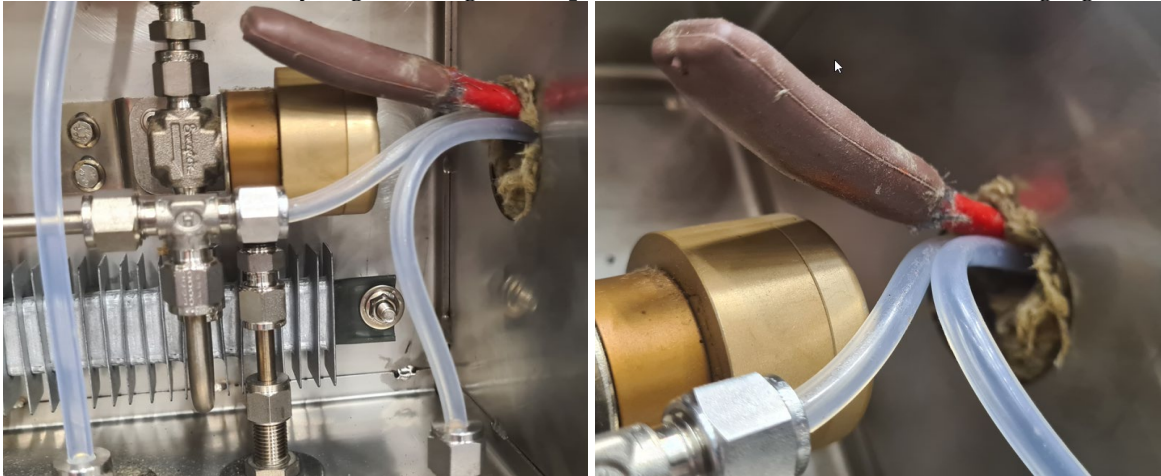

- 21) Shrink the expanded nose by applying heat with a heat gun. Move the heat gun back and forth to apply heat evenly. Stop heating when the nose has assumed the shape of the heated sample line and glue have started to squeeze out of the joints.



---

*Note*                    *The HSL is powered from the SCC.*

---

### 7.8.1.3 Adding a Multiplexer (Slave) Option

Several Multiplexers can be connected in series to increase the total number of streams. Each additional Multiplexer adds three streams as one of the power connections is used for the link. In the steps below the link is connected to the left side of the Multiplexer.

The Master Multiplexer is installed according to previous steps in this installation manual.

Three different installations of the Slave Multiplexer are presented on below.

#### Standard 5-7 Stream Config:

- Analyser HSL feeds from Analyser System.
- SSM Master have 3-streams and feeds power to LINK HSL.
- Additional streams (#4 - #7) from SSM Slave

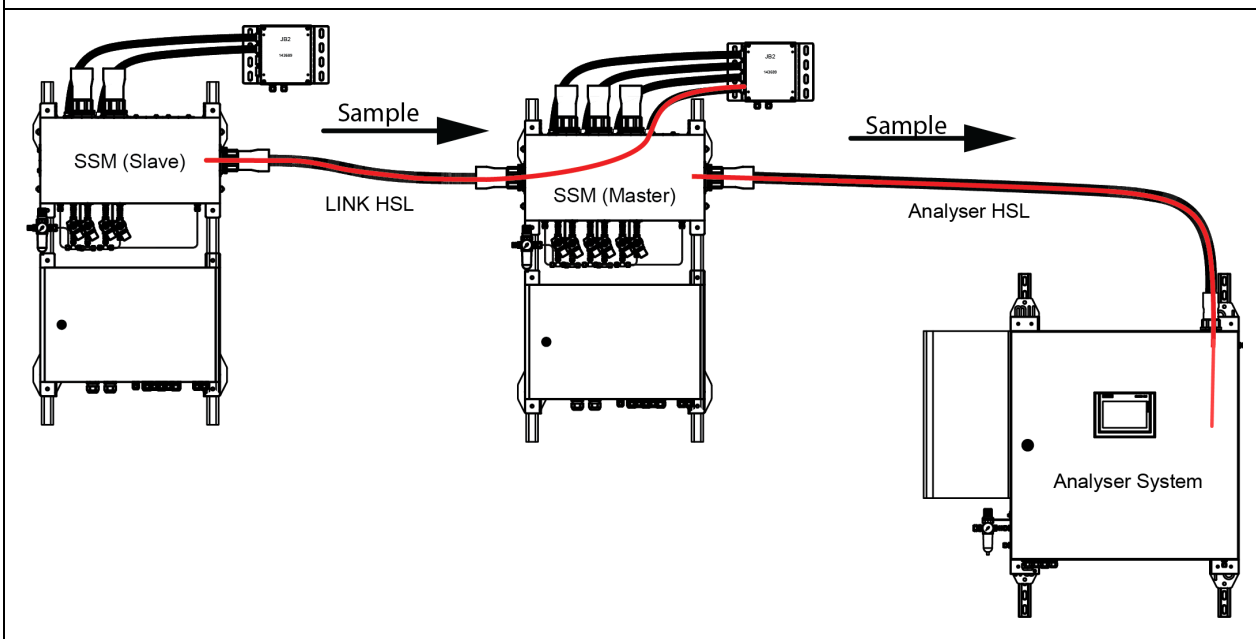

**Special Config (on PO request):**

- Analyser HSL feeds from Analyser System.
- SSM Master has 4-streams.
- Additional streams (#5 - #7) from SSM Slave that feeds power to LINK HSL

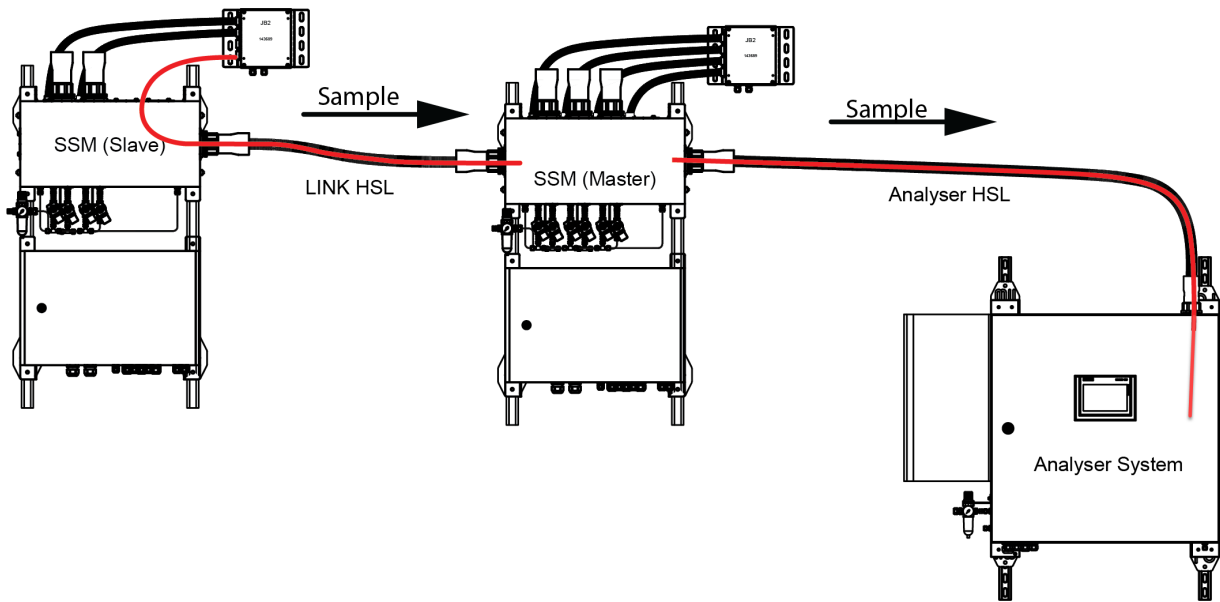

**Special Config (on PO request):**

- Analyser System have no extra power.
- SSM Master has 3-streams and feeds power to Analyser HSL.
- Additional streams (#4 - #6) from SSM Slave that feeds power to LINK HSL.

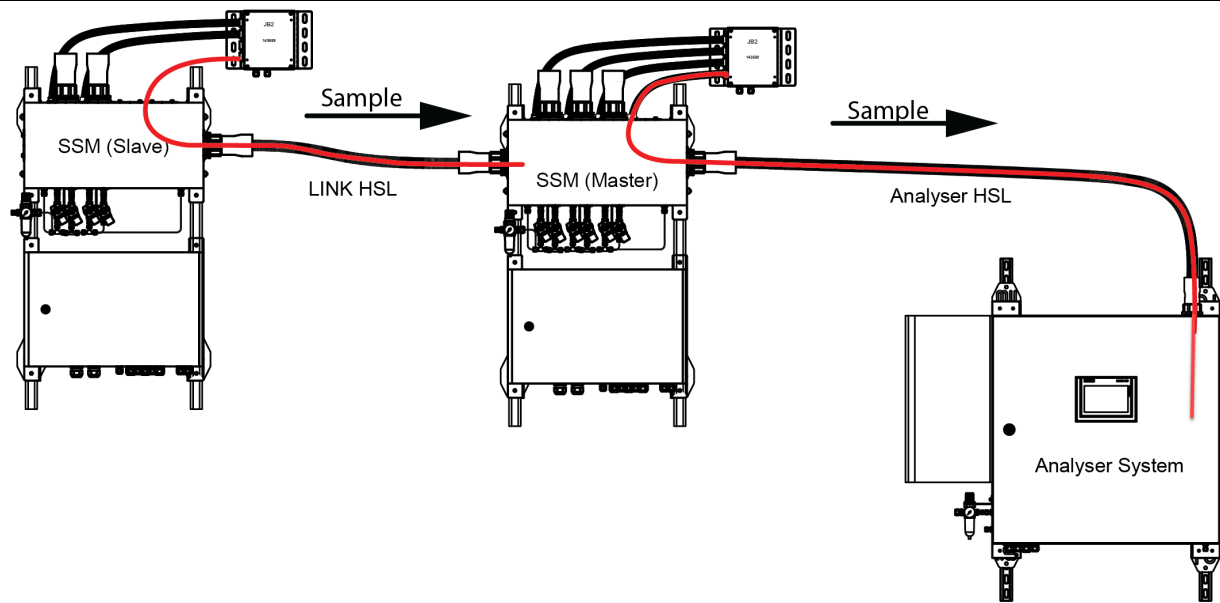

## 7.9 Finalising the installation

### 7.9.1 Connection

For HSL connection to the Analyser System refer to the installation manual e.g. 50118-D22 ShipCEMS Compact Installation Manual.

- 1) Connect instrument air supplied by the ship to nozzle N11 using a 10 mm outer diameter flexible tube or hose. **DO NOT USE A RIDGID PIPE CONNECTION.**  
The cabinet must be able to move freely on the wire dampers. Use the 10 mm nut set included in the Multiplexer installation kit. The instrument air supply must be oil-free and free of particulate matter. The dew point must be less than  $-17^{\circ}\text{C}$  ( $-1.4^{\circ}\text{F}$ ).

---

*Note*                      *If required, install an absorbing chemical unit to the instrument air header upstream the Multiplexer. This will prevent traces of oil entering the system.*

*Note*                      *If the air supply contains moisture, install an air dryer unit to the instrument air header upstream the Multiplexer.*

---

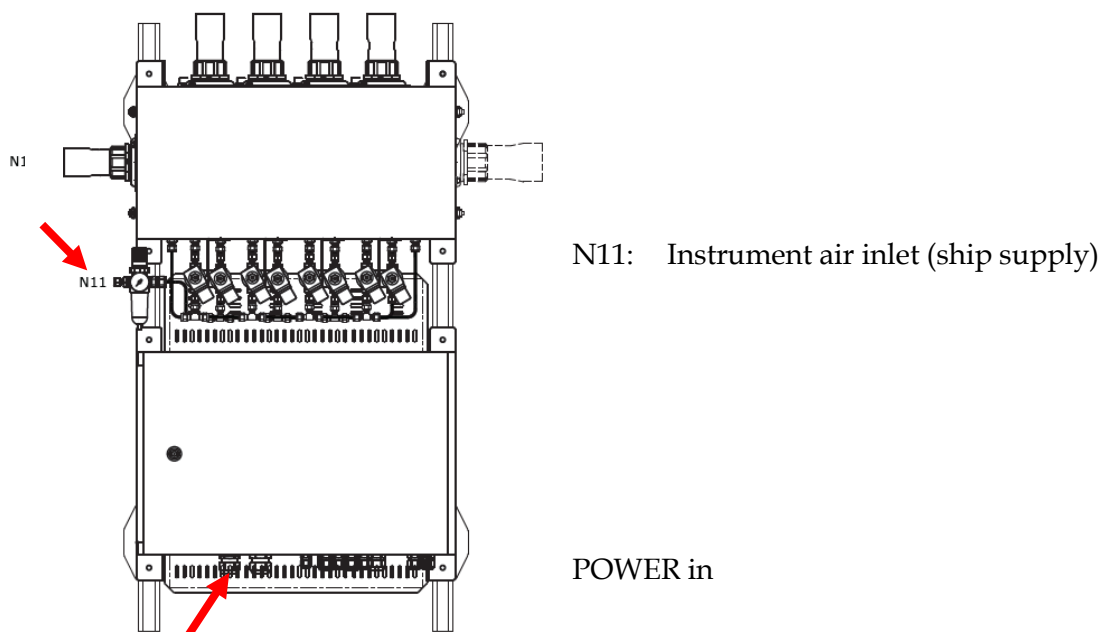

Figure 14 Multiplexer instrument air in and power

#### Power:

- 2) Power cable entrances are through cable glands at the left-hand bottom of the Multiplexer. Connect power supply at the dedicated terminals inside the electrical junction box (to the power terminals). Refer to drawing 50118-5102.

**TCP/IP (LAN:**

**First Multiplexer, Master:**

- 3) LAN cable entrances are through cable glands at the right-hand bottom of the Multiplexer. Connect a LAN cable to the PLC X1 port and route it to the SCC cabinet (switch).

**Added Multiplexer, Slave:**

- 4) Connect a LAN cable to the PLC X1 port and route it to the Master Multiplexer PLC X2 port.

## 7.9.2 Field bus specification

Request the following document:

→ *50118-D212 Field bus specification*

# 8 Installation checklist

After the installation has been performed and before the Multiplexer is brought into operation for the first time, the checklist described in this chapter must be completed to confirm a correct installation.

It is recommended to set aside time at the end of the installation phase specifically for these tests.

All results from the tests and any remarks to the product or the test results shall be recorded by hand in the accompanying tables.

The installation checklist shall be signed by the installation contractor when completed. This chapter shall then be printed or scanned and be returned to Norsk Analyse prior to commissioning.

---

*Note*                      *Return a scanned copy of the Installation checklist with results and if applicable remarks to Norsk Analyse after installation. Send to [service@norskanalyse.com](mailto:service@norskanalyse.com) and write the following in the subject field:*

***Multiplexer installation checklist, Project number:*** \_\_\_\_\_

*Warranty does not apply unless the scanned copy of the Installation checklist is returned to Norsk Analyse.*

---

	<b>Action</b>	<b>Acceptance criteria</b>	<b>Result</b>	<b>Remark</b>
1.	Check that all units have been delivered. Units shall be handled and installed in accordance with GA and details drawings	All units delivered and installed in accordance with GA and details drawings.	<input type="checkbox"/> Accepted <input type="checkbox"/> Not accepted	
2.	Check that the units are not damaged.	No mechanical damages, scratches or dents shall be observed.	<input type="checkbox"/> Accepted <input type="checkbox"/> Not accepted	
3.	Check that each unit is accessible for operation and maintenance work.	Verify service access (Multiplexer cabinet door can open completely, necessary access to internal modules, proper lightening etc.).	<input type="checkbox"/> Accepted <input type="checkbox"/> Not accepted	

	Action	Acceptance criteria	Result	Remark
4.	Check the Multiplexer's vibration mounting.	<p>Verify that the Multiplexer is fastened using proper mounting bolts and tighten.</p> <p>Make sure that the cabinet can move freely on the wire dampers and is not restricted by any cables, tubes etc.</p>	<input type="checkbox"/> Accepted <input type="checkbox"/> Not accepted	
5.	Check the sample probe.	<p>Verify that the spool piece/counter flange is welded to the stack as specified (50118-1202).</p> <p>Verify that the sample probe flange is fastened using proper mounting bolts and tighten.</p> <p>Verify that the probe quill is correctly inserted.</p> <p>Verify that the ceramic filter is mounted and undamaged.</p>	<input type="checkbox"/> Accepted <input type="checkbox"/> Not accepted	
6.	Check the external tubing.	<p>Verify that instrument air is connected as specified.</p> <p>Make sure that the tubing is supported and protected from breakage.</p>	<input type="checkbox"/> Accepted <input type="checkbox"/> Not accepted	
7.	Check the internal tubing.	<p>Verify that all heated sample line has been correctly installed in the Multiplexer, probe and SCC.</p> <p>Unused connection must be capped.</p>	<input type="checkbox"/> Accepted <input type="checkbox"/> Not accepted	

	Action	Acceptance criteria	Result	Remark
8.	Check for loose fittings.	Check tightness by hand.	<input type="checkbox"/> Accepted <input type="checkbox"/> Not accepted	
9.	Check instrument air.	Verify that instrument air is dry and oil free acc. to ISO 8573-1:2010 class 4.3.4.	<input type="checkbox"/> Accepted <input type="checkbox"/> Not accepted	
10.	Check the heated sample line.	Verify that the heated sample line is sufficiently supported, and that the minimum bending radius is adhered to.	<input type="checkbox"/> Accepted <input type="checkbox"/> Not accepted	
11.	Check the heated sample line.	Verify that there are no water traps.	<input type="checkbox"/> Accepted <input type="checkbox"/> Not accepted	
12.	Check the electrical cabling.	Verify that all power and signal cables are routed are terminated for Multiplexer (JB1) and JB2 according to termination and wiring diagrams.	<input type="checkbox"/> Accepted <input type="checkbox"/> Not accepted	
13.	Check for loose wires.	Verify that all connections in junction boxes and internal terminal blocks are tight and secure.	<input type="checkbox"/> Accepted <input type="checkbox"/> Not accepted	
14.	Check electrical fuses.	Verify that all equipment is connected to its correct fuse.  Verify correct current rating for all fuses.	<input type="checkbox"/> Accepted <input type="checkbox"/> Not accepted	

To be filled in by installation contractor:

Installation contractor	
-------------------------	--

Ship name / hull no.	
Ship owner	
<b>Checks performed by (date/sign)</b>	
<b>Checks verified by (date/sign)</b>	

# 9 References

## 9.1 Drawings

The Multiplexer drawings below are sent as separate files, prior to delivery.

DWG	Description	230V	120V
<b>Mechanical drawings:</b>			
50118-1101	SAMPLE STREAM MULTIPLEXER (SSM) HOOK-UP LOCATIONS	X	
50118-1102	SAMPLE STREAM MULTIPLEXER (SSM) GENERAL ARRANGEMENT	X	
50118-1106	SAMPLE STREAM MULTIPLEXER (SSM) WIRE DAMPERS ON UNISTRUT	X	X
<b>System drawings:</b>			
50118-3101	SAMPLE STREAM MULTIPLEXER (SSM) SYSTEM DIAGRAM	X	
<b>Electrical drawings:</b>			
50118-5101	TERMINATION DRAWING - OVERVIEW SAMPLE STREAM MULTIPLEXER (SSM)	X	
50118-5102	TERMINATION DIAGRAM POWER DISTRIBUTION SAMPLE STREAM MULTIPLEXER (SSM)	X	
50118-5103	TERMINATION DIAGRAM SIGNAL DISTRIBUTION SAMPLE STREAM MULTIPLEXER (SSM)	X	
50118-5005	TERMINATION DIAGRAM SAMPLE PROBE	X	

<b>Block diagrams:</b>			
50118-6101	SYSTEM BLOCK DIAGRAM P&ID DISTRIBUTION OVERVIEW SAMPLE STREAM MULTIPLEXER (SSM)	X	X
50118-6102	SYSTEM BLOCK DIAGRAM SIGNAL AND POWER DISTRIBUTION OVERVIEW SAMPLE STREAM MULTIPLEXER (SSM)	X	X
<b>Network map</b>			
50118-8201	NETWORK MAP, MULTIPLEXER NETWORK SAMPLE STREAM MULTIPLEXER (SSM)	X	X

## 9.2 Documents

DWG	Description	230V	120V
SSM-D21	USER MANUAL	X	X
SSM-D212	FIELD BUS SPECIFICATION	X	X

# 10 Installation overview

The overviews on the three following pages are extracts from the termination drawings below as well as fieldbus specification

The extracts should be considered as generic examples.

- [50118-5101] – *TERMINATION DRAWING - OVERVIEW SAMPLE STREAM MULTIPLEXER (SSM)*
- [50118-5102] – *TERMINATION DIAGRAM POWER DISTRIBUTION SAMPLE STREAM MULTIPLEXER (SSM)*
- [50118-5103] – *TERMINATION DIAGRAM SIGNAL DISTRIBUTION SAMPLE STREAM MULTIPLEXER (SSM)*
- [50118-5005] – *TERMINATION DIAGRAM SAMPLE PROBE*

---

*Note*                      *Always follow the latest revision of the drawing!*

---

© Norsk Analyse

