



Installation Manual ShipCEMS Compact

ShipCEMS Continuous Emission Measurement System



SHIP **CEMS**
COMPACT

This page is intentionally left blank!



Installation Manual ShipCEMS Compact

ShipCEMS Continuous Emission Measurement System

The purpose of this installation manual is to provide the information required to install ShipCEMS Compact in a safe and efficient manner.

This manual is intended for personnel performing the installation. The information supplied shall be used as basis for the installation contractor's own drawings applicable to the ship. On completion of the installation, this manual must be kept on the ship for reference purposes during system maintenance.

Revision status

Revision	Date	Prepared	Checked	Approved
Rev. 01	01.06.2023	ALI	CRA	JHJ
Rev. 02	22.06.2023	ALI	CRA	JHJ

Document history

Revision	Reason for issue
Rev. 01	First issue. Renamed from NA-E-INS-106
Rev. 02	Heated sample line installation in probe added. 7.1.1 and 7.2.4.

Copyright

© Norsk Analyse

No part of this document may be reproduced, copied, modified, or translated in any form or by any means, without the prior written approval from Norsk Analyse.

Important

Before using the equipment, read all instructions thoroughly and follow all precautions and warnings contained within this document. Improper use may cause personal injury and/or damage to the equipment and may void the warranty. Norsk Analyse disclaims any responsibility for damage or injury caused by improper installation, use or maintenance of the equipment.

Table of contents

1	INTRODUCTION.....	8
1.1	Purpose.....	8
1.2	Scope conditions.....	8
1.3	Contact details.....	9
2	GENERAL SAFETY RULES	10
2.1	High voltage.....	10
2.2	Hazardous components.....	10
2.3	Heavy equipment.....	10
3	SYSTEM DESCRIPTION	11
3.1	System overview.....	11
3.2	Example of layout.....	12
3.3	Sample and calibration gas flow.....	14
3.4	Power distribution.....	15
3.5	Signal distribution.....	16
4	EQUIPMENT HANDLING	17
4.1	Transportation.....	17
4.2	Inspection at receipt.....	18
4.3	Lifting.....	18
4.4	Pre-installation storage.....	19
4.5	Unpacking.....	20
5	TECHNICAL SPECIFICATIONS.....	21
5.1	Environmental requirements.....	21
5.2	Physical dimensions.....	21
5.3	Ingress protection.....	21
5.4	Materials.....	22
5.5	Power supply.....	22
5.6	Power consumption.....	22
5.7	Measuring range.....	22
5.8	Calibration gas (span).....	23
5.9	Instrument air.....	23

6	INSTALLATION GUIDELINES	24
7	INSTALLATION PROCEDURES	25
7.1	Recommended installation sequence	25
7.1.1	Sample probe	25
7.2	Heated sample line (wet)	27
7.2.1	Preparation	28
7.2.2	Heated sample line connection in SCC	29
7.2.3	End termination of tracer cable on probe side	35
7.2.4	Heated sample line connection on probe	37
7.3	Calibration gas cylinder	40
7.4	SCC	40
7.4.1	Remove plugs	44
7.4.2	Signal Exchange list	44
8	INSTALLATION CHECKLIST	45
9	REFERENCES	49
9.1	Drawings	49
9.2	Documents	50
10	INSTALLATION OVERVIEW	51

Acronyms and abbreviations

Back-purge	Cleaning of probe by flushing instrument air
CEMS	Continuous Emissions Monitoring System
CO ₂	Carbon dioxide
DWG	Drawing
EGCS	Exhaust Gas Cleaning System (scrubber)
GA	General Arrangement (Drawing)
N ₂	Nitrogen
PFA	Perfluoroalkoxy alkane (plastic tube material)
PLC	Programmable Logic Controller
PTFE	Polytetrafluoroethylene (plastic tube material)
SO ₂	Sulphur dioxide
SP	Sample probe
SCC	ShipCEMS Compact

Admonitions

<i>Note</i>	<i>Text set off in this manner presents clarifying information or specific instructions relevant to the immediate instruction.</i>
<i>Caution</i>	<i>Text set off in this manner provides a warning notice that failure to follow the directions in this caution can result in damage to equipment.</i>
<i>Warning</i>	<i>Text set off in this manner provides a warning notice that failure to follow the directions in this warning can result in bodily harm or loss of life and/or extensive damage to equipment.</i>
DANGER	TEXT SET OFF IN THIS MANNER PROVIDES A WARNING NOTICE THAT FAILURE TO FOLLOW THE DIRECTIONS IN THIS WARNING WILL RESULT IN BODILY HARM OR LOSS OF LIFE AND/OR EXTENSIVE DAMAGE TO EQUIPMENT.

1 Introduction

1.1 Purpose

The purpose of this installation manual is to provide the information required to install the Continuous Emission Monitoring System (SCC) in a safe and efficient manner.

This manual is intended for personnel performing the installation. The information supplied shall be used as basis for the installation contractor's own drawings applicable to the ship.

Chapter 7 Installation procedures goes through the steps of the installation from mounting the sample probe to internet connection.

On completion of the installation, this manual must be kept on the ship for reference purposes during system maintenance.

In addition to this installation manual, a drawing package is prepared for your system to facilitates installation of power and signal. Request the drawing package or support at: support@norskanalyse.com

1.2 Scope conditions

The installer performing the installation becomes fully responsible for the ShipCEMS equipment upon receipt unless otherwise stated in the contract. The duration of responsibility includes:

- The time the equipment is stored locally before installation.
- During the entire installation process.
- While commissioning the equipment.
- The time between commissioning and the final acceptance of the equipment by the ship owner.

Note *Prior to installation, check all units for damage as described in the chapter 4.*

Note *Installation check list needs to be signed and sent to Norsk Analyse in order to obtain warranty of the SCC. Refer to chapter 8.*

1.3 Contact details

For enquiries related to sales, service, support, maintenance, and spare parts, please contact us at:

Norsk Analyse
P.O. Box 2313, 3103 Tønsberg, Norway
www.shipcems.com

Phone: +47 3337 5100
Fax: +47 3337 5149

Support: support@norskanalyse.com
Service: service@norskanalyse.com
Spare parts: marine@norskanalyse.com

2 General safety rules

Safety precautions must always be followed during installation, operation, and maintenance of the system. Personnel shall be sufficiently qualified, and proper caution shall be taken to avoid injuries or damage to life, health, environment, equipment, and property.

2.1 High voltage

Warning *ShipCEMS operates at a potentially lethal AC voltage.*

Always switch off all power before installation or maintenance. Adhere to safety precautions and instructions as directed by company policy. For safety reasons during troubleshooting on the equipment with power ON, two persons must always be present. Whenever installation or maintenance is carried out, it is essential that a first aid kit is available, and that personnel are familiar with the first aid instructions for electrical shock.

2.2 Hazardous components

Warning *Many toxic gases are colourless, odourless, and non-irritating, and may overcome exposed persons without notice.*

The sample gas may contain trace amounts of hazardous components. Personnel should have a thorough knowledge and understanding of the physical properties and safety precautions for the relevant gas samples before operating the system. Gas inlets and outlets are hot in heated analyser systems. Skin contact may result in serious burns even for a long period after the equipment has been switched off. Make sure the ventilation is good especially if the SCC is in a small room. Ensure that gas has access to free air.

2.3 Heavy equipment

The SCC is a heavy unit. Do not open SCC door while in rough seas. Doors may suddenly swing open and cause damage or injury. Use appropriate safety clothing and certified lifting equipment during installation or replacement of larger units!

3 System description

3.1 System overview

The main purpose of the ShipCEMS Compact system is to analyse exhaust gas. sulphur dioxide and carbon dioxide in wet marine exhaust gas.

ShipCEMS compact is designed and manufactured for the marine environment, hence ship movements, vibrations and temperature loadings are attended to during design of the system. The sample treatment technology selected is optimised for this specific trace analysis.

ShipCEMS Compact is designed for unmonitored, continuous operation, but all system units may also be manually operated. The user interface is simple and intuitive, with a limited number of operations necessary to use the system.

Self-test diagnosis of analyser maintenance, analyser faults and so on are run periodically. If any test should fail, an error message will be displayed on the HMI, and an alarm signal is also sent to the customer. If a potentially harmful fault occurs, appropriate actions will automatically be taken.

The ShipCEMS consists of the following main units:

- SCC
- Analyser module
- Programmable logic control
- Heated sample probe
- Heated sample line (5 to 30 metre)
- Cabinet cooler

Optional equipment covered by this manual:

- Calibration gas (span and nitrogen)
- Air dryer unit and mounting kit
- Air compressor

Optional gas cylinders are provided by the ship owner or by Norsk Analyse as specified by contract.

External tubing and electrical interface cables to be provided by installer.

Note Equipment provided locally by the installation contractor or by local dealers is not described in this manual.

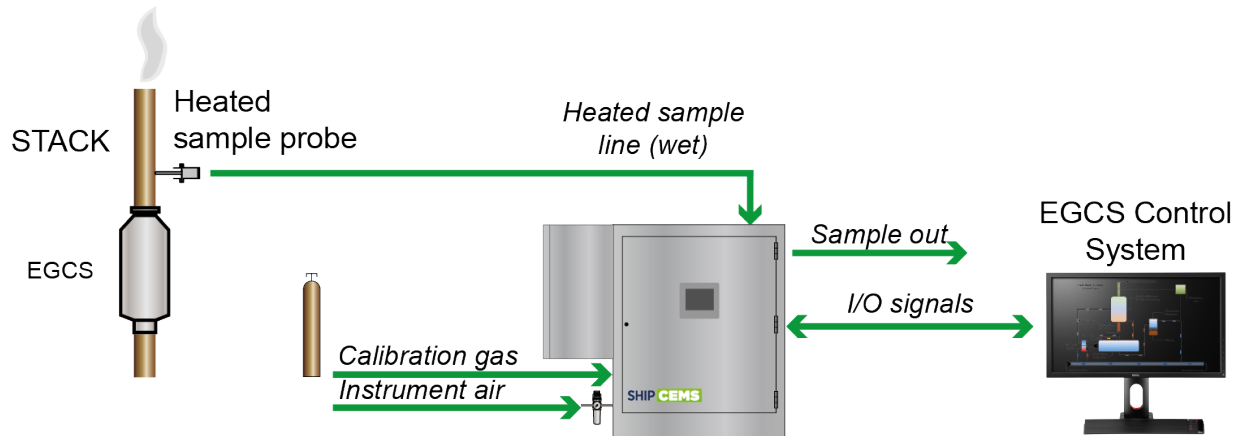

Figure 1 Block diagram for ShipCEMS Compact analyser system

3.2 Example of layout

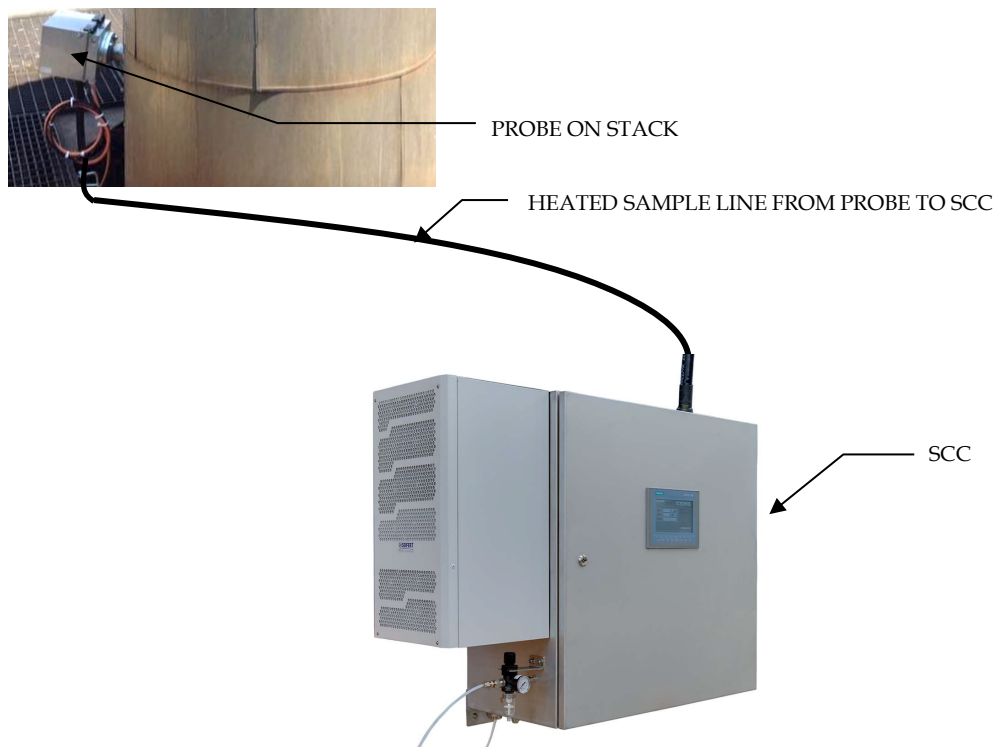

Figure 2 ShipCEMS Compact main parts

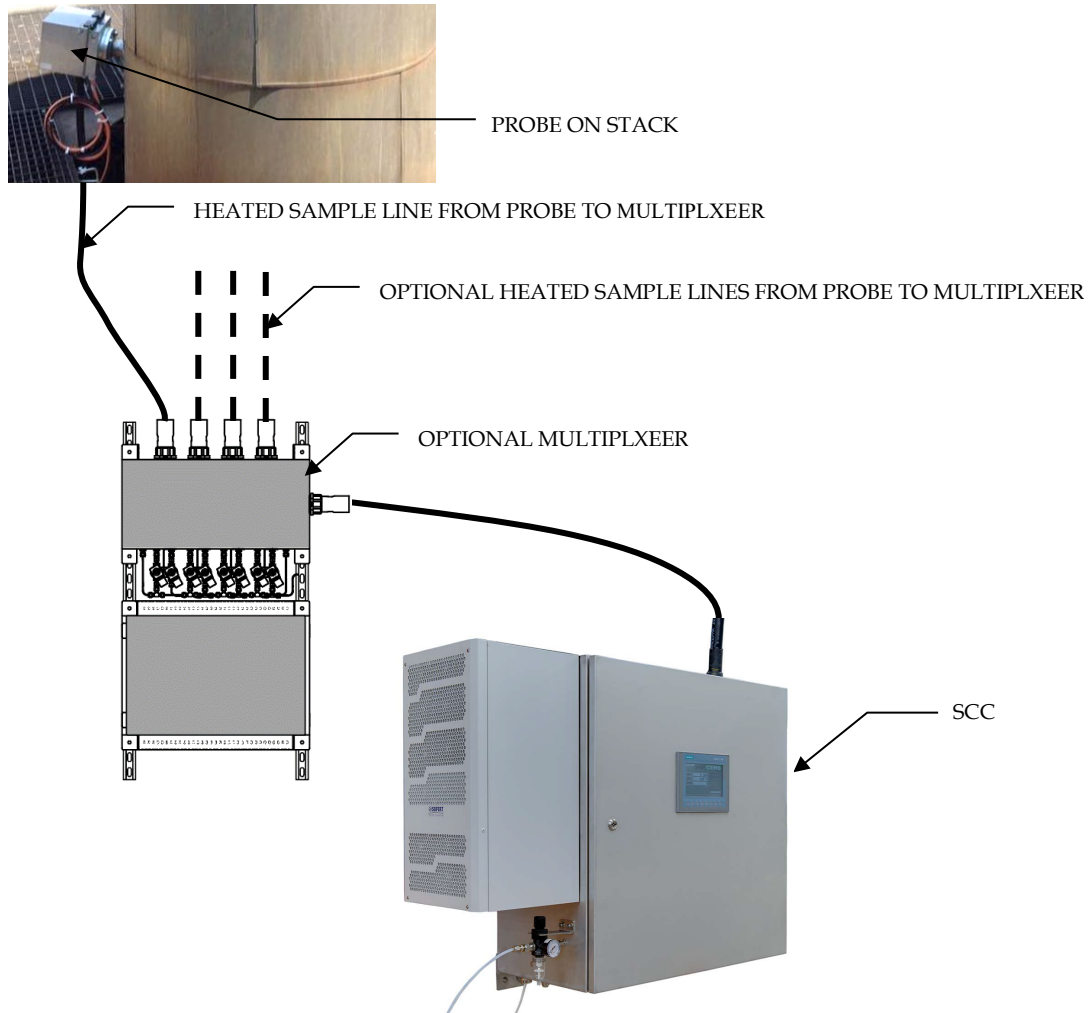

Figure 3 ShipCEMS Compact main parts with multiplexer

3.3 Sample and calibration gas flow

Instrument air supply is provided by the ship. The tube is provided and installed by the installation contractor (refer to A in Figure 3 and to utility requirements ShipCEMS). All other tubes are provided by the manufacturer but is installed by the installation contractor (refer to B-F2 in Figure 3).

Warning *F1 and F2: Outlet gas and calibration gas from SCC needs to be vented to free air. If SCC is installed in a small room, the outlet gas level will increase unless it is vented. For personal safety, ensure the outlet gas has access to free air.*

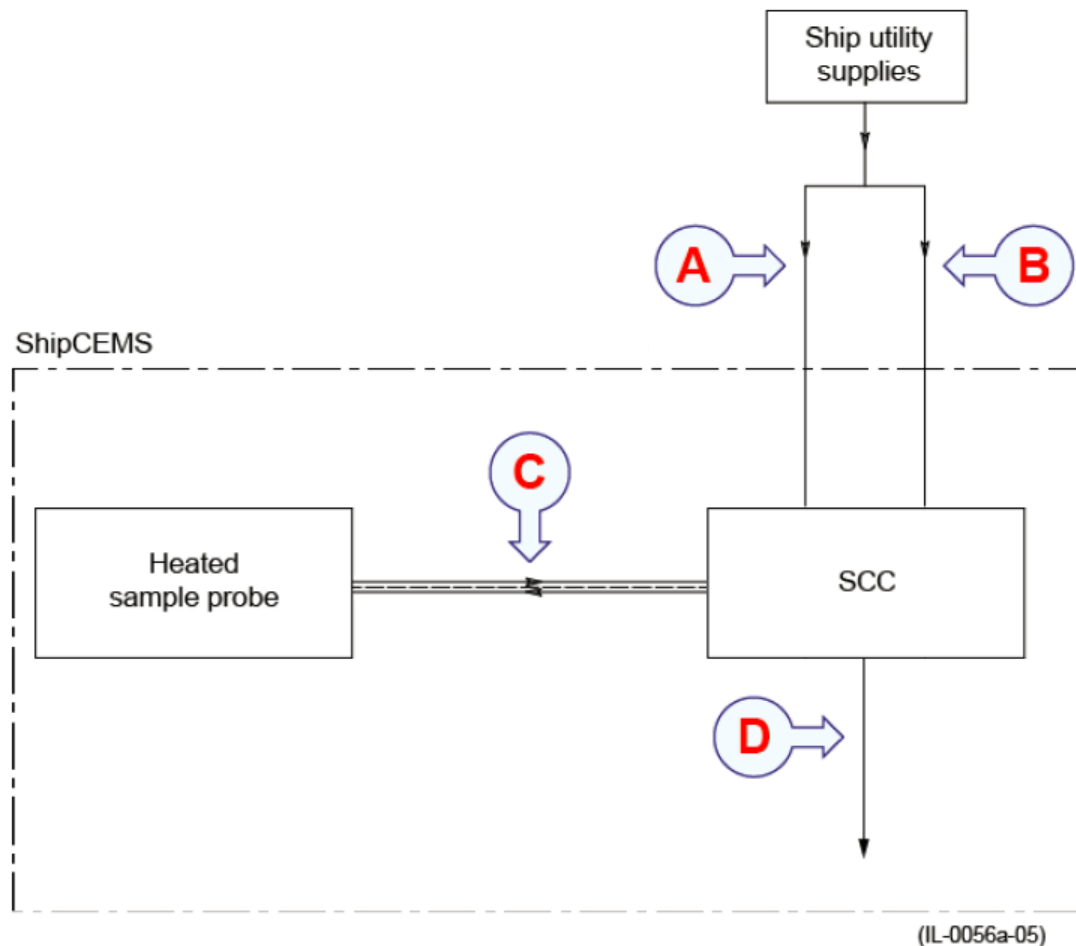

Figure 4 Block diagram – sample and calibration gas flow

- A: Instrument air supply, 10 mm o.d. tube, SS316 compression tube fitting
- B: Calibration gas, 6 mm o. d. tube, SS316 compression tube fitting
- C: Heated sample line (wet), 37 mm o. d. PFA/PTFE tube, with calibration gas to Sample probe.
- D: Analyser Atm. vent

3.4 Power distribution

ShipCEMS Compact requires continuous power supply 120V or 230V, 50/60 Hz to operate. The minimum requirement for the power feed cables is:

- 230V: 2 x 2.5 mm² + PE (protective earth)
- 120V: 2 x 2.5 mm² + PE (protective earth)

All system units must be connected to a local On/Off two-pole power switch located within a radius of 1.5 metres. All switches must be provided by the installation contractor.

Warning *Use the appropriate circuit breaker in the ship's switchboard and label the breaker with a warning sign informing that installation work is being carried out. Inform installer before connecting the external power.*

The circuit breaker label can only be removed after all power and signal interfaces have been connected.

The whole system is powered from the ShipCEMS Compact, SCC.

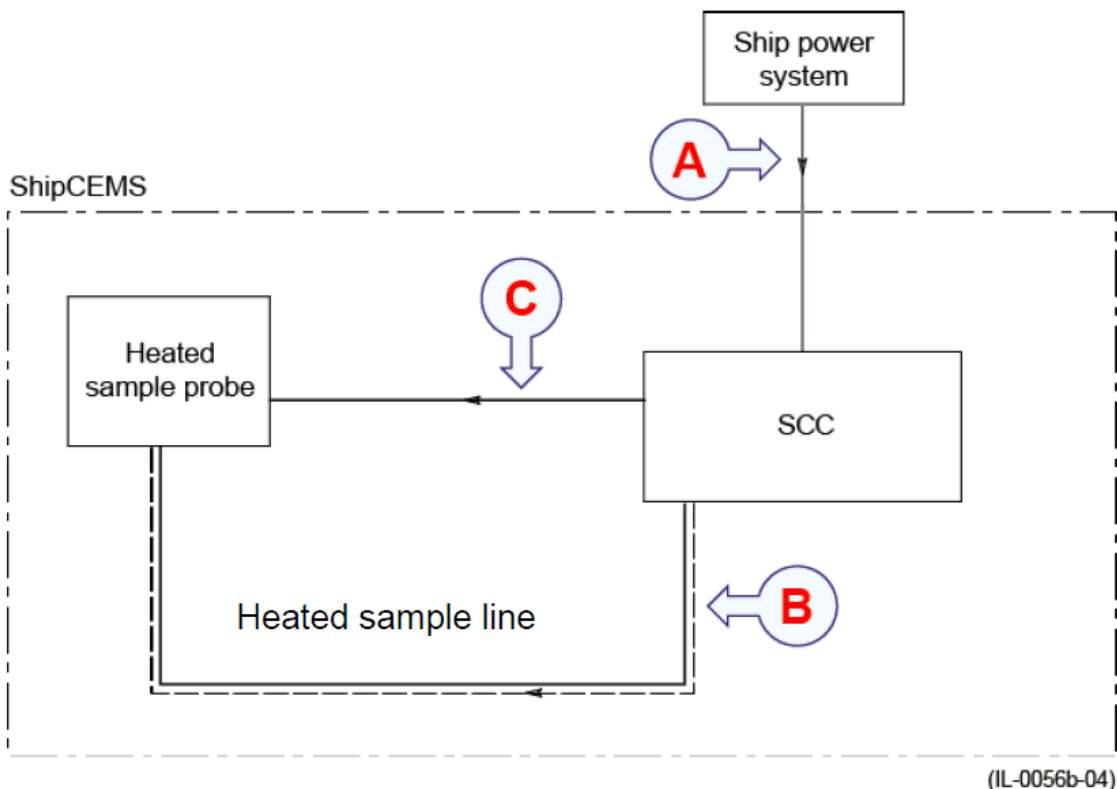

Figure 5 Block diagram – power distribution
A: Power supply, 2-phase
B: Heated sample line from SCC
C: Power feed from SCC

3.5 Signal distribution

Refer to the following block diagrams for overview:

→ [6001] System Block Diagram Pipe and Gas Distribution Overview

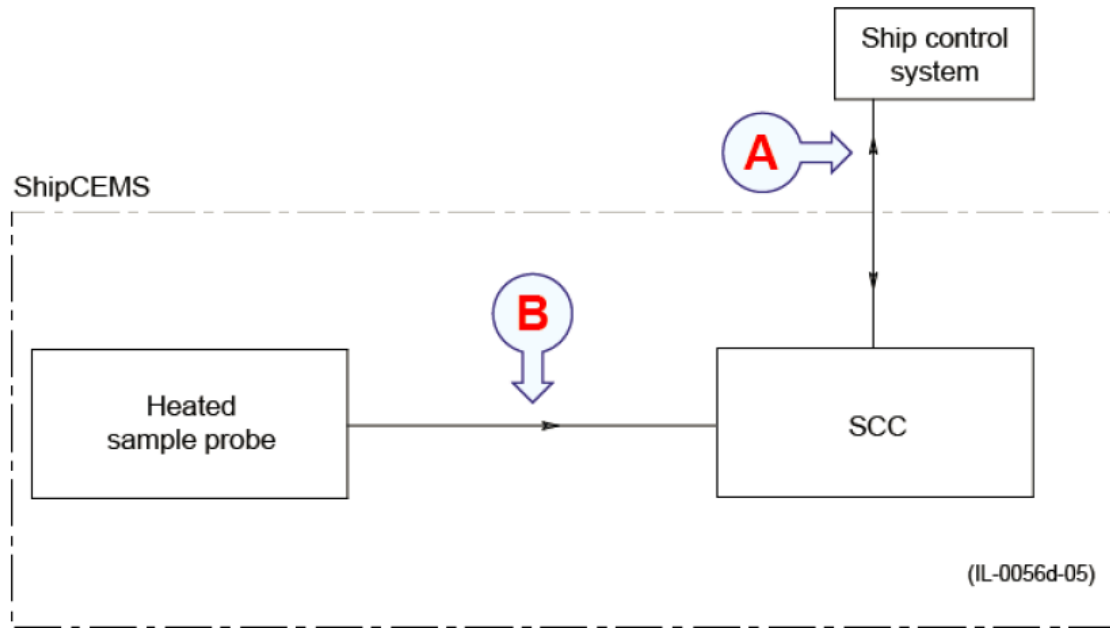

Figure 6 Block diagram – signal distribution
A: Fieldbus communication
B: Alarm signal (digital)

4 Equipment handling

This chapter describes the equipment handling procedures needed for the installation contractor to evaluate the equipment dispatch and to make plans for receipt, storage, and installation of the equipment.

Note *Failure to adhere to instructions given may render the warranty void.*

Caution *During all stages of equipment handling, including installation, use adequate protective covers to shelter the equipment from falling objects from overhead work or similar.*

4.1 Transportation

Unless otherwise stated in the accompanying documentation, equipment supplied by Norsk Analyse can be transported using all methods approved for fragile equipment. The units must be transported in accordance with general or specific instructions for the appropriate units, using pallets, transport cases or carton boxes as appropriate.

- 1) Always keep the equipment dry and ensure it is sheltered from weather.
All equipment shall therefore be transported below deck for sea transport, and preferably under a canopy for road transport.
- 2) When equipment is marked with text and symbols indicating which way it is to be placed, follow the instructions given.
- 3) Ensure that ambient conditions, such as temperature and humidity, are always within the equipment's specifications.
- 4) Securely restrain the equipment to avoid mechanical damage and injury to the equipment and to personnel.
- 5) Ensure that the equipment will not be subject to shock, excessive vibrations or other rough handling.
- 6) Handle equipment containing fragile electronic components, such as analyser model, with special care.

4.2 Inspection at receipt

A visual inspection must be carried out immediately after the equipment has arrived at its destination to check for any transport or unloading damages.

- 1) Check all pallets, wooden boxes, plastic bags and other packing media for physical damage. Look for signs of dropping, immersion in water or other mishandling.
- 2) If damage is detected externally, open the packaging to check the contents. Request a representative of the carrier to be present while opening, so any transportation damage to single units can be identified.
- 3) If any unit is damaged, prepare an inspection report stating the condition of the unit and actions taken. The report shall be sent promptly to Norsk Analyse.

4.3 Lifting

Heavy equipment will normally be marked with its weight. To ensure selecting the correct lifting apparatus, always check the weight of the equipment before attempting to lift it.

Caution *Please handle all equipment with care to avoid damage due to sudden shock or impact.*

- 1) SCC and similar equipment are mounted onto pallets and can be lifted by a forklift or a pallet truck.
- 2) The SCC is equipped with lifting lugs (Ø15 mm in 4 mm SS316 plate) and can be lifted by a crane or a winch.

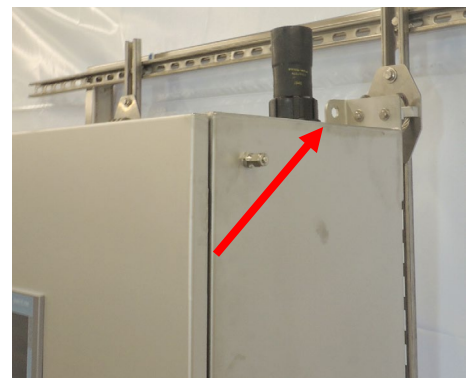

- 3) Instrument boxes, sample probes and other smaller units can be removed from pallets by hand.

4.4 Pre-installation storage

The equipment should be stored in its original transport case until ready for installation. Transport cases must not be used for any purpose for which they were not intended.

It is recommended that the equipment is stored indoors until placed in its intended operating position.

If stored outdoors and exposed to ambient conditions, additional heaters provided by the installation contractor must be used inside SCC to avoid any vapour to condense in electronic and electrical equipment prior to commissioning and start-up.

- 1) Keep the equipment in a dry, non-condensing atmosphere, free from corrosive agents and isolated from sources of vibration.
- 2) Ensure that the temperature at the storage location is at least +15°C (+59°F) with a relative humidity of 0 to 95 % (non-condensing).
- 3) Carefully unload SCC onto their foundation or at levelled foundations at the site's storage facilities.
- 4) If stored in a humid environment, ensure that SCC are heated to avoid failure of built-in sensitive instrumentation, such as analysers. Note that sample probes and similar equipment may be stored in an unheated environment.
- 5) Close all doors and other openings to prevent ingress of dust, dirt and moisture.
- 6) Always lock the SCC to prevent unauthorised personnel accessing the equipment.

4.5 Unpacking

Normal precautions must be undertaken during unpacking to prevent damage to equipment or to personnel.

It is recommended to store equipment (unless equipment is prepared for immediate use) in its original packing.

Equipment must be installed in its intended operating position as soon as possible after unpacking.

- 1) Place the transport case to be unpacked on the floor or on a stable work bench.
- 2) When equipment is marked with text and symbols indicating which way it is to be placed, follow the instructions given.

Caution *Use certified lifting apparatus when handling heavy units.*

Caution *Be careful when working with pallets and wooden boxes.
The metal edges of such units may be sharp.*

- 3) Check the transport case for signs of dropping, immersion in water or other mishandling.
- 4) Open the transport case using appropriate tools. Open the case carefully to ensure the contents are not damaged.

Caution *If a wooden box has been closed using screws, always remove them using a screwdriver. Do not attempt to force the lid off with a crowbar or similar.*

Caution *Do not use a knife to open cardboard cartons, as the contents may lie close to the surface, and may therefore be damaged by the blade.*

- 5) Once the transport case is open, carefully remove all loose packing and insulation material before lifting out and installing the equipment contained.

Caution *Tubing and cable must never be used as carrying handles or lifting points.*

- 6) Also check the transport case for additional equipment that may have been added to the cradle during packing such as manuals, special tools, door keys etc.

5 Technical specifications

5.1 Environmental requirements

SCC is designed to comply with IACS E10 - Test Specification for Type Approval

5.2 Physical dimensions

Item	Specification
SCC Cabinet	
Dimensions (W x D x H)	1105 x 475 x 1200 mm
Weight	120 kg (265 lbs.)
Heated sample probe	
Probe length	254 mm (10")
Quill length	500 mm (20") (or other customer specific)
Flange diameter	160 mm (DN65 PN6) or 175 mm (JIS flange 10K DN65) (or other customer specific)
Weight	10 kg (22 lbs.)
Sample probe counter flange	
Dimensions	160 mm (DN65 PN6) or 175 mm (JIS flange 10K DN65) (or other customer specific)
Heated sample line (wet)	
Diameter (OD)	50 mm (1 7/16")
Weight	1.2 kg/m (0.4 lbs./ft.)

5.3 Ingress protection

- IP44

5.4 Materials

Item	Specification
SCC Cabinet	SS316L
Tubing	PTFE
Fittings	SS316L
Heated sample probe quill	SS316L or hastelloy
Heated sample probe counter flange	SS316L (or customer specific)

5.5 Power supply

Item	Specification
SCC: Power from ship switchboard	230V, 2-phase, 50/60 Hz
Power cable specifications	230V: 2 x 2.5 mm ² + PE

5.6 Power consumption

Item	Specification
SCC	1350 W
Sample probe	400 W
Heated sample line (wet)	67 W/m
Sample Line (dry)	15 W/m if ambient temperature < +5°C Non heated if ambient temperature > +5°C

5.7 Measuring range

Item	Specification
SO ₂	0-200 ppm to 0-1000 ppm 0.1% Sulphur cap: 0-50 ppm 0.5% Sulphur cap: 0-200 ppm
CO ₂	0-5% to 0-15% 0.1 and 0.5%: 0-10%

Item	Specification
O ₂	0-25 mol%
NO _x	0-2000 ppm
CO	0-2000 ppm
CH ₄	0-1000 ppm

5.8 Calibration gas (span)

Item	Specification
Gas composition Standard specifications. Other gas compositions may be ordered on request.	160 ppm SO ₂ , 8 mol% CO ₂ Rest Nitrogen N ₂
Zero gas, Nitrogen	For raw gas applications.
Cylinder size	10 litre (typical)
Cylinder pressure	> 100 barg (> 1500 psig)
Cylinder pressure	5 litre / min / calibration

5.9 Instrument air

Item	Specification
Quality	Dry, oil-free according to ISO 8573-1:2010 class [4: 3: 4]: Dew point: ≤ -17°C Particles per m ³ (1-5µm): ≤ 10 Total oil: 0.01 mg/m ³
Consumption	Minimum 15 NI/min (0.9 Nm ³ /hour) @ atmospheric pressure
Pressure range	6 to 8 barg (90 to 120 psig)
Dew Point	<+3°C @ 8 barg minimum outlet pressure (lower than -17°C @ atmospheric pressure)

6 Installation guidelines

SCC is subject for approvals by classification societies. The approval design and verification are obtained according to the latest IACS E10 revision.

Best practice proven over many years of experience by the installation contractor can be used to implement other installation solutions than what Norsk Analyse recommends. As the installation contractor has the final EMC responsibility, the installation contractor must ensure that the installation complies with classification rules. The classification society may also enforce additional requirements influencing the installation. The installation contractor must ensure that the SCC installation complies with any additional requirement defined by the classification society.

SCC must be installed by skilled personnel and be supervised by a technician with relevant experience. Recommendations and requirements for installation of main system items are listed in the following.

Note *Failure to adhere to instructions given may render the warranty void.*

All work shall be carried out in accordance with approved drawings. Therefore, prior to installation, the drawing file prepared by Norsk Analyse shall be consulted.

Note *Detailed plant specific mechanical drawings for the installation must be provided by the installation contractor, or any contractor performing the installation. Norsk Analyse may, on special order, provide assistance to these drawings.*

Note *All physical dimensions in this manual are given in millimetres (metric).*

Caution ***Instruments, cables, and other electrical equipment must be protected against mechanical damage during installation.***

Observe that the SCC framework structure is of stainless-steel material SS316L. Plan your installation procedures accordingly. Install SCC on reinforced floor/wall or structural beams.

Caution ***As instruments are sensitive devices, do not weld onto the SCC framework.***



If planning to install any SCC units outdoors, weatherproof protection must be provided. Also avoid installing in open areas with heavy winds, sea splash zones and other areas not suitable for service and maintenance activities.

7 Installation procedures

7.1 Recommended installation sequence

The installation procedures are listed in the preferred installation order.

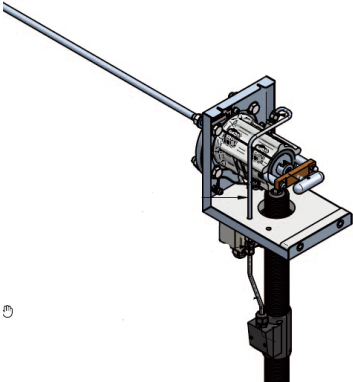
7.1.1 Sample probe

Step	Description	Ref in manual
1.	Refer to Sample probe Operating Manual – Appendix A.	
2.	Mount quill on sample probe. Use the small gasket. 	
3.	<p>Check inclination on counter flange. The quill should point 5-20° towards the stack.</p> <hr/> <p><i>Note For installations where water droplets are present at sample point inlet it is recommended to install the probe with inclination 20 degrees.</i></p> <hr/> 	
4.	Mount sample probe on the counter flange (that is welded onto the stack). Use the large gasket. 	
5.	Connect all cables between sample probe and SCC. Refer to drawings.	

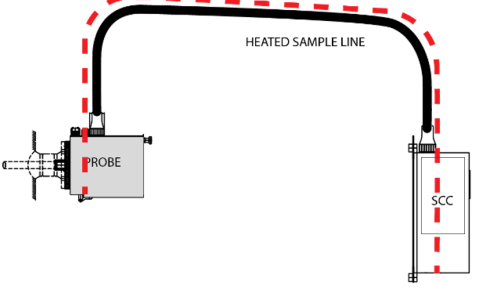
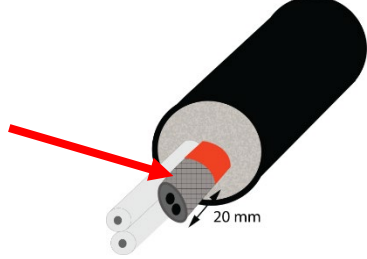
Step	Description	Ref in manual
6.	<p>Place the heated sample line between sample probe and SCC.</p> <p>Avoid water traps.</p> <p>Refer to Figure 7 for preferred indoor and outdoor installation.</p> <p>Measure length to be cut.</p> <p style="text-align: center;">- - - - -</p>	
7.	<p>Install heated sample line in SCC. It can be installed from the top or the right side.</p> <p>Terminate according to procedure.</p>	
8.	<p>Make end termination of heated sample line on the probe side – heat tracer cable only!.</p>	
9.	<p>Check that all tubing is correctly fastened.</p>	
10.	<p>Connect instrument air and optional external air dryer unit.</p>	
11.	<p>Connect calibration gas.</p>	
12.	<p>Remove plugs.</p>	
13.	<p>Go through Installation checklist when everything is installed.</p>	

7.2 Heated sample line (wet)

The heated sample line is supplied on a reel or similar. We recommend that the heated sample line is installed downward towards the SCC, unless other options are better suited for the installation. Refer to *Figure 7*.

The heated sample line must be cut to actual length. Refer to chapter 7.3.1.

Avoid areas where the ambient temperature may exceed +45°C (+113°F).

The heated sample line is an insulated tube bundle consisting of two lines (one for sample, one for calibration) and a tracer cable (heating element). Refer to figure below.

The figure below with the electric end termination is connected to the probe. The other end of the heated sample line is connected inside the SCC. Refer to Figure 7.



Figure 7 Heated sample line to be connected to probe

Caution *All electrical connections and installations must comply with the requirements of all applicable national and local codes. If there is a conflict between these instructions and the requirements of applicable codes, the requirements of the codes must be followed.*

7.2.1 Preparation

- 1) Roll out the heated sample line on a flat surface.
- 2) Route the heated sample line along existing structures such as cable trays and beams to provide enough support.

Caution *Observe the minimum bending radius of 200 mm when installing the heated sample line to avoid breakage of the internal tubing and heat tracer cable.*

- 3) Make sure that there will not be any water traps in the heated sample line.

Caution *Water trap will interfere with the sample and cause flow alarms! Refer to Figure 7.*

- 4) Do not cut heated sample line yet.
- 5) Measure against probe and SCC. Calculate distance between probe and SCC + 300 mm for the probe and 700 mm for the SCC.

The picture below shows the preferred installations. The red dashed line represents the total heated sample line to be cut. Refer to Figure 7.

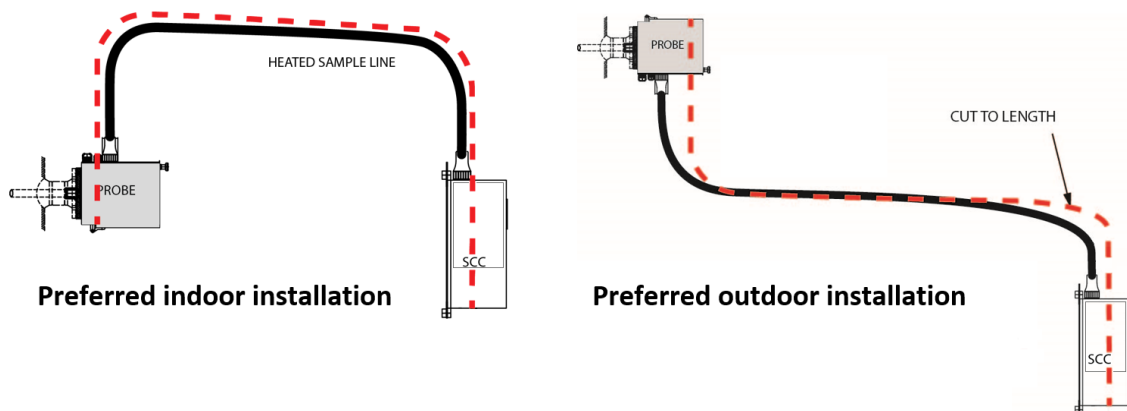

Figure 8 *Measure heated sample line length*

- 6) Permanently secure the heated sample line using metal clamps. Make sure to use a enough support points along the route, typically every meter to avoid water traps. Exception is above the SCC; as it must be able to move freely on the wire dampers. It is not recommended to have any support closer than 1.5 meter from entering the SCC.
- 7) Cut the heated sample line.
- 8) Temporarily seal both ends of the cable using a plastic bag.

7.2.2 Heated sample line connection in SCC

Strip the heated sample line at an appropriate length (700 mm) to be sure that the tracer cable can be connected to the power connection kit on the inner right side of the SCC.

Caution *Take care not to damage the internal tracer cable and sample tube.*

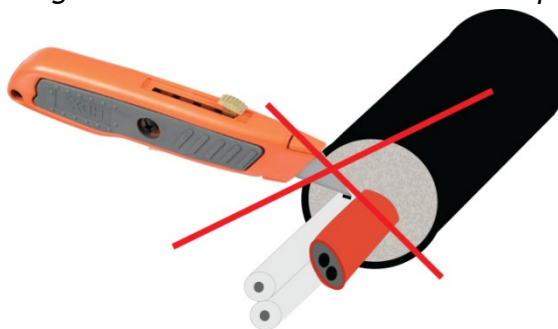

Caution *If the tubes are damaged the whole heated sample line must be replaced.*

The tracer cable will be connected to the power cable using the power connection kit supplied with the SCC.

- 9) Place the threaded nut through nozzle N5 on top of the SCC so that the flanged end is on the inside of the SCC.
- 10) Adjust and cut the 6 mm sample tube at an appropriate point and connect the end to the sample inlet using the fitting supplied with the SCC.
- 11) Also cut the 6 mm calibration tube, connect the end to the Flow Control Valve located under the analyser.
- 12) Shrink the expanded nose by applying heat with a heat gun. Move the heat gun back and forth to apply heat evenly. Stop heating when the nose has assumed the shape of the heated sample line and glue have started to squeeze out of the joints.

Caution *Hold the heated sample line approx. 5 minutes while the heat-shrinkable nose and glue sets. Otherwise, the heated sample line will "slide" inside the nose prior to the glue setting, causing the heated sample line to be dislocated. Apply instrument air to speed up the process.*

- 13) Install power connection in SCC (using low profile connection).

Caution *Do not power up yet. Heated sample line must be connected at the probe first!*

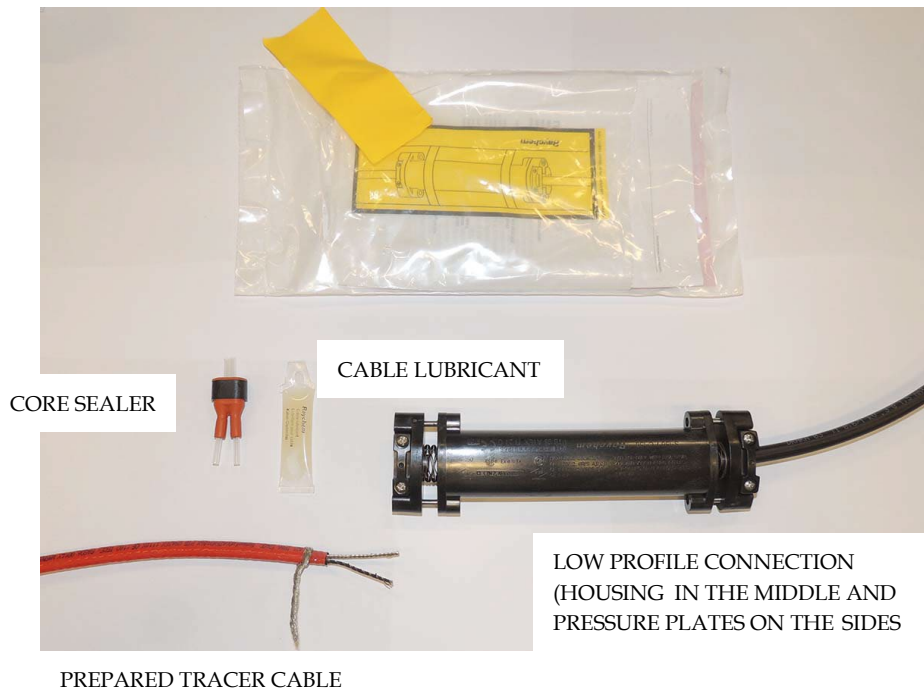
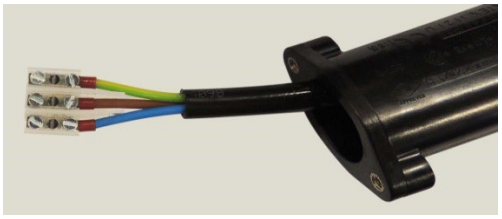

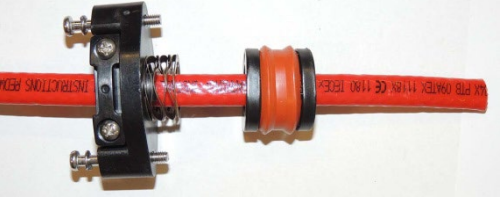

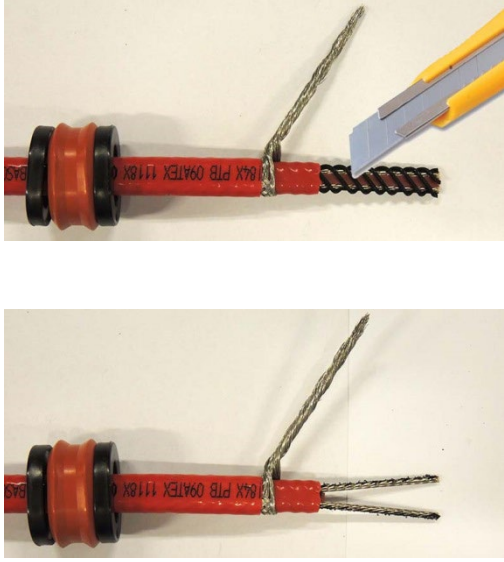
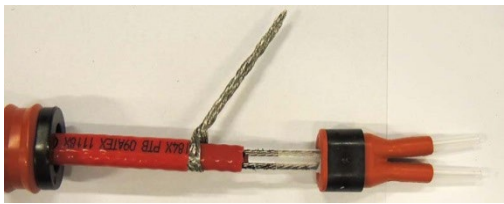
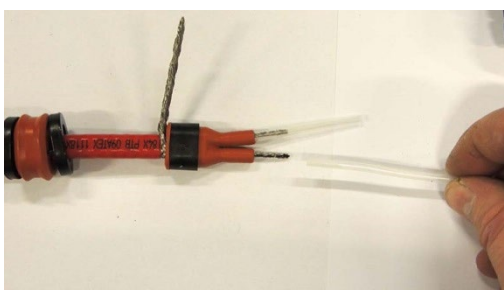
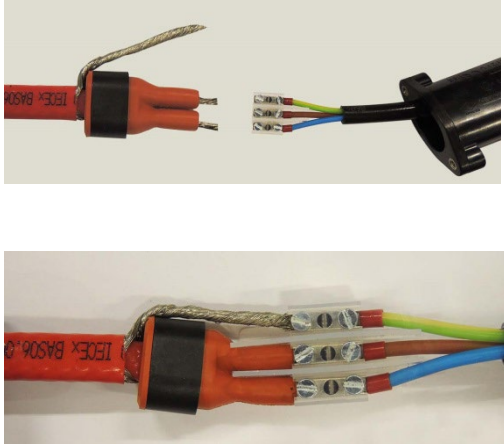
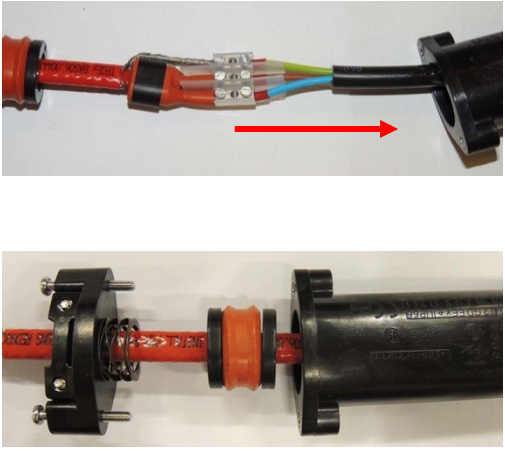

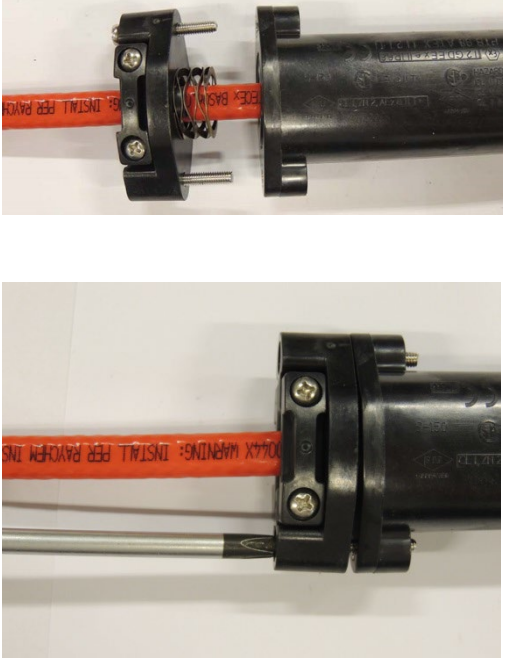

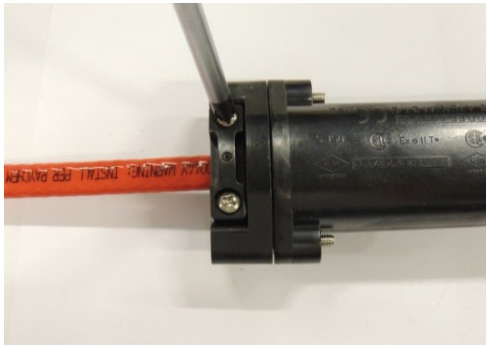

Figure 9 Power connection kit

a)	Remove the cable clip holding the power cable in the right side of the SCC.	
b)	Check that the 2 screws on the right pressure plate are loose (for cable to run freely).	
c)	Disconnect pressure plate on the left side using 4 screws.	

d)	Push/pull the power cable through the housing.	
e)	Line up the tracer cable, pressure plate and the sealing grommet.	
f)	Apply lubricant inside the connection.	
g)	Push the tracer cable through the pressure plate and the sealing grommet.	
h)	Remove 70 mm of the outer jacket.	
i)	Spread out and twist the screen (metal threads) to a single wire.	

<p>j)</p>	<p>Remove 50 mm of the inner jacket.</p> <ul style="list-style-type: none"> • Cut the heating threads with a knife and remove but be careful not to damage the electric wires. • Cut off the brown support under the heating threads using cutting pliers. Dispose. 	
<p>k)</p>	<p>Thread the electric wires into the transparent guiding tubes of the core sealer.</p> <p>Push the core sealer all the way to the braid.</p>	
<p>l)</p>	<p>Remove the 2 guiding tubes.</p>	
<p>m)</p>	<p>Connect the braid to the ground cable on the terminal block.</p> <p>Connect the other two wires to the terminal block.</p>	

<p>n)</p>	<p>Pull the connection into the housing.</p>	
<p>o)</p>	<p>Apply cable lubricant from the kit to the sealing grommet.</p>	
<p>p)</p>	<p>Attach the pressure plate to the housing using 2 screws.</p>	

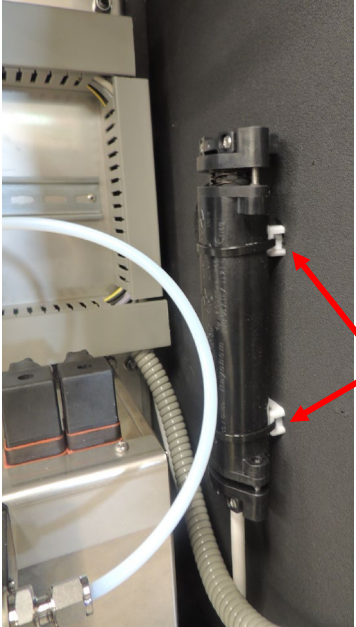
<p>q)</p>	<p>Secure the cable to the left pressure plate using 2 screws.</p>	
<p>r)</p>	<p>Secure the right pressure plate to the housing using 2 screws.</p>	
<p>s)</p>	<p>Secure the power cable to the right pressure plate using 2 screws.</p>	
<p>t)</p>	<p>Reattach the low-profile connection to the side of the SCC using the black plastic strips.</p> <hr/> <p><i>Note</i> <i>Strips are included in a strip kit at the bottom of the SCC.</i></p> <hr/>	

7.2.3 End termination of tracer cable on probe side

- 1) Place the heated sample line from the SCC (where it is connected) to the probe. Make sure there are no water traps, and that the length is long enough.
- 2) Strip the heated sample line at an appropriate length ensuring that the sample tube can be connected to the sample outlet and the calibration tube can be connected to the calibration inlet of the probe.

Caution *Take care not to damage the internal tracer cable, sample tube and calibration tube.*

The tracer cable shall have a length that allows the sample to be heated throughout.

- 3) End termination of tracer cable: Follow the steps in the table below.

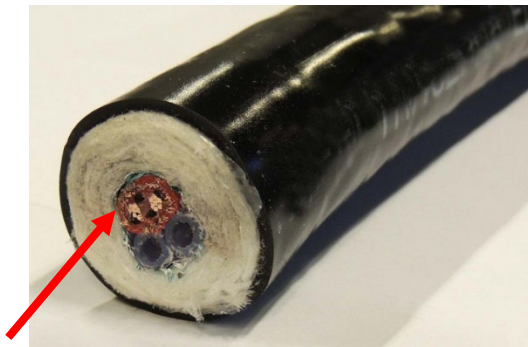
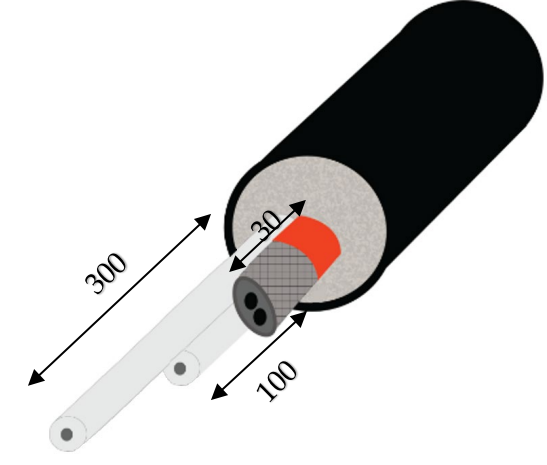
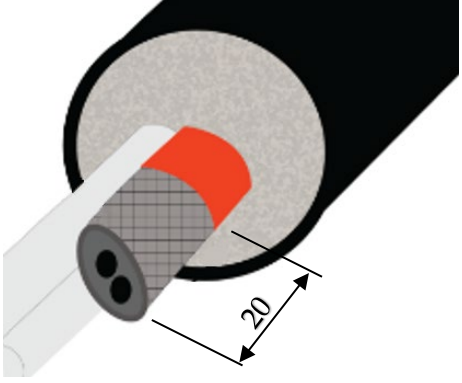

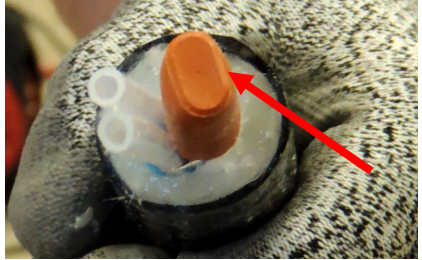

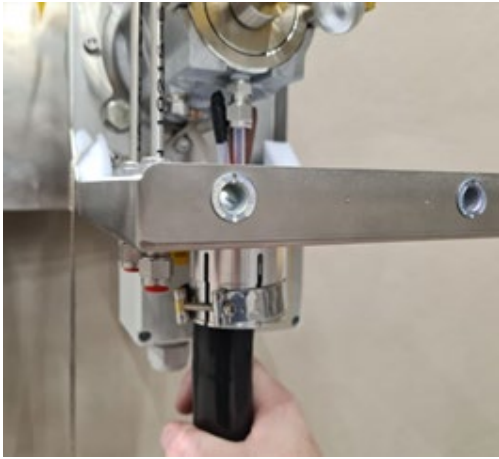
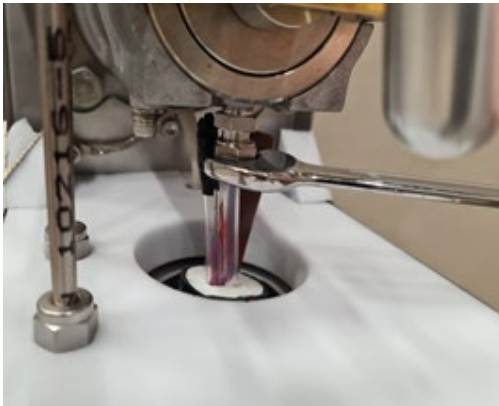

Figure 10 *Heated sample line as delivered*

T9G90-UC Kit Contents (kit is inside SCC, refer to Figure 19)	
1 pcs Silicone Tracer End Cap	
1 pcs Tube of RTV Silicone	
1 pcs Silicone Two-Leg Connection Sleeve - not used	
1 pcs Ring Terminal - not used	
1 pcs Entry Seal - not used	
1 pcs 36" (915mm) Heat Shrink Tubing - not used	

<p>a)</p>	<ul style="list-style-type: none"> • Cut off 300 mm of the heated sample line insulation to expose sample line, calibration line and tracer cable. • Cut the heat tracer cable to 30 mm above the insulation • Let the sample line be 100 mm above insulation and the calibration line be 300 mm. • Make sure there is no contact between electric leaders and shield. 	
<p>b)</p>	<p>Cut off 20 mm of the orange insulation to make the screen (metallic threads) visible.</p>	
<p>c)</p>	<p>Remove 20 mm of the screen (metallic threads).</p>	
<p>d)</p>	<p>Cut end cap to half length. Fill silicone end cap with RTV silicone and slide over end of cable. Hold while it sets. Make sure there is no contact between the two cables after the cut.</p>	
<p>e)</p>	<p>Cover the entire insulation surface with RTV silicone to prevent water and condensation from entering.</p>	

7.2.4 Heated sample line connection on probe





<p>1.</p>	<p>Ready for heated sample line connection.</p>	
<p>2.</p>	<p>Push the heated sample line through the cylinder.</p> <p>From cabinet blow instrument air through the teflon sample line to verify that correct tubing is installed in the probe.</p> <p>While holding the tube bundle in place, connect the active sample line to the probe.</p> <p>Fasten the active sample line using 14mm or 9/16 open wrench..</p>	  

3. Mount the calibration line to the calibration nozzle using 14mm or 9/16 open wrench..



On the first deliveries the calibration nozzle might be located as on picture to the right.



<p>4. Mount the first insert and tap it gently inside the cylinder using a small hammer.</p> <p>Mount the second insert, outside the first insert to get it started by hand, but do not push it all the way in. Pushing can cause a kinked sample line inside the probe!</p> <p>When slightly inserted, tap it gently inside the cylinder using a small hammer. Do not overlap gaps.</p> <p>Tighten the clamp to hold the tube bundle in place.</p>	   
---	--

7.3 Calibration gas cylinder

Analyser gas is available in different compositions depending on the range of the analyser in your specific system.

Part no: **135030**: 160 ppm SO₂, 8 mol% CO₂, Rest N₂
 125621: 40 ppm SO₂, 8 mol% CO₂, Rest N₂
 135142: 160 ppm SO₂, 12 mol% CO₂, Rest N₂
 TBA: Nitrogen (zero calibration)

Unless the order states differently, the standard calibration gas cylinder has the following dimension: Ø175 mm, height 800 mm. Volume: 10 litres.

Connector: DIN 14 (unless others specified in order)

Caution *Make sure that gas cylinders are prevented from falling.*

- 1) Connect the gas cylinder to nozzle N1. Use the coil and regulator provided in the delivery.
- 2) Refer to user manual for procedure for parameter settings in chapter "Install or replace calibration gas cylinder".
- 3) Proper support for the calibration gas must be made to ensure the bottle is securely fastened.



7.4 SCC

Warning *Outlet gas from the SCC needs to be vented to free air. If the SCC is installed in a small room, the outlet gas level will increase unless it is vented. For personal safety, ensure the outlet gas has access to free air.*

Drawing references:

- [50118-1001] -HOOK-UP LOCATIONS
- [50118-3001] - SYSTEM DIAGRAM ANALYSER CABINET

(*) Option

To avoid vibrations the SCC cabinet is mounted onto wire dampers.

Prior to mounting the SCC cabinet, anchor rails with wire dampers are mounted to the vessel's framework. Note that there are a left and a right rail. The left wire damper has two coils (due to the weight of the air conditioner) and the right wire damper just one coil.

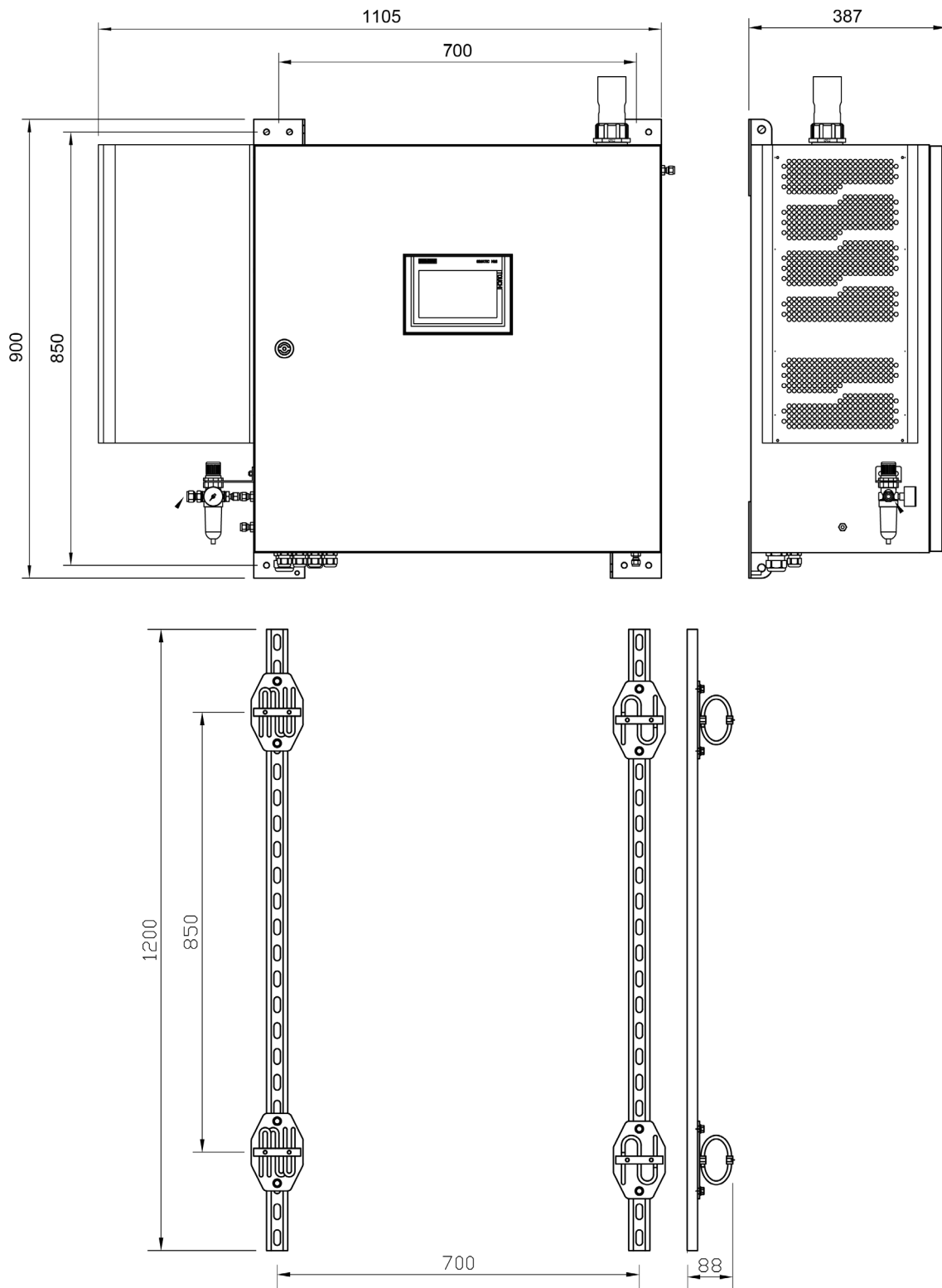

Figure 11 SCC and anchor rails with dampers, outline dimensions

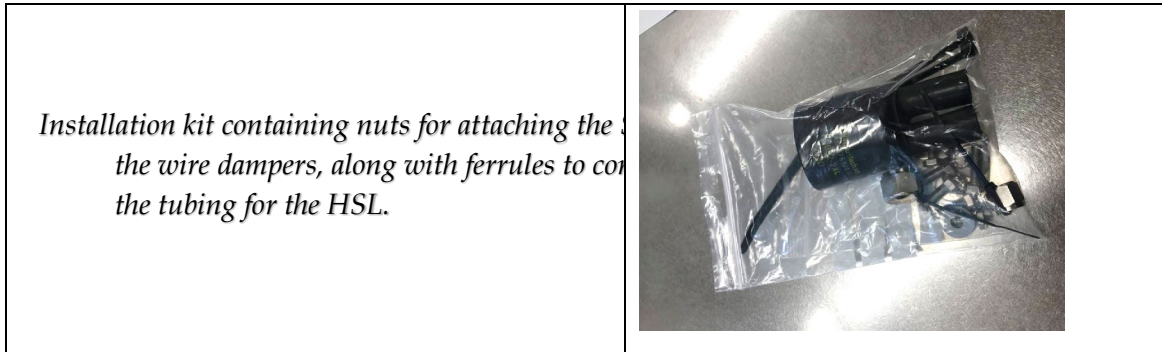

Figure 12 Compact installation kit located in the SCC

Find a suitable and stable location for the SCC. The SCC must be mounted on ship's structural beams. To ensure maintenance access, make sure that the SCC is installed with adequate spacing in all directions.

Caution Do not install the SCC onto the stack!

- 1) Prepare the installation framework (not NAAS supply) by welding steel support for the SCC on the ship's casing.
- 2) Mount the two anchor rails (with dampeners) to the framework. Refer to Figure 18. It is recommended to use minimum 6 x M10 bolts (not included) with nuts, three on each of the vertical support frame bars. The upper bolt on each support bar shall be mounted above the lifting lugs. The arrangement should be fixed using flat washers and external tooth locks.

Note that the wire damper on the left rail has double coils.

- 3) Lift the SCC cabinet onto the prepared framework using the two lifting lugs. Refer to Figure 18. Fasten the cabinet in the wire damper with 8 x M6 bolts and fasteners from the ferrule kit. The dampeners can be adjusted in height to compensate for the weight of the SCC.

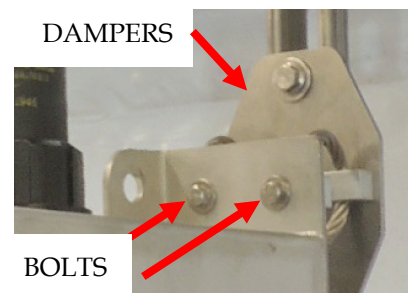

Note

The SCC requires instrument air supply to operate. The air supply pressure shall be 6 to 8 barg (90 to 120 psig). Air supply is provided by the ship. Refer to technical specifications on instrument air in chapter 5.10.

- 4) Connect instrument air supplied by the ship to nozzle N1 using a 10 mm outer diameter flexible tube or hose. DO NOT USE A RIDGID PIPE CONNECTION. The cabinet must be able to move freely on the wire dampers. Refer to Figure 20. Use the 10 mm nut set included in the SCC installation kit. The instrument air supply must be oil-free and free of particulate matter. The dew point must be less than -17°C (-1.4°F).

Note *If required, install an absorbing chemical unit to the instrument air header upstream the SCC. This will prevent traces of oil entering the system.*

Note *If the air supply contains moisture, install an air dryer unit to the instrument air header upstream the SCC.*



Figure 13 SCC inlets/outlets

- N1: Sample outlet (atmospheric vent)
 N2: Instrument air inlet (ship supply)
 N4: Calibration gas inlet

- 5) Connect calibration span gas to nozzle N4 using a 6 mm outer diameter PFA/PTFE tube.
- 6) Cable entrances to the analyser system are through cable glands at the left-hand bottom of the SCC. Connect power supply at the dedicated terminals inside the SCC box (to the circuit breaker).
- 7) Connect TCP/IP (LAN) signals to the ship's vessel control system at the dedicated terminals inside the SCC.
- 8) Ensure that the internal signal cables are properly fastened to the analyser module.

7.4.1 Remove plugs

At delivery, sample out, drain, instrument air and calibration in are plugged to prevent ingress of dust. Refer to Figure 21 Remove these plugs, marked red in the figure below, before start-up. Make sure to vent to ventilated area.

Caution *Remove plugs to avoid build-up of pressure in the SCC and thereby destroying the analyser.*

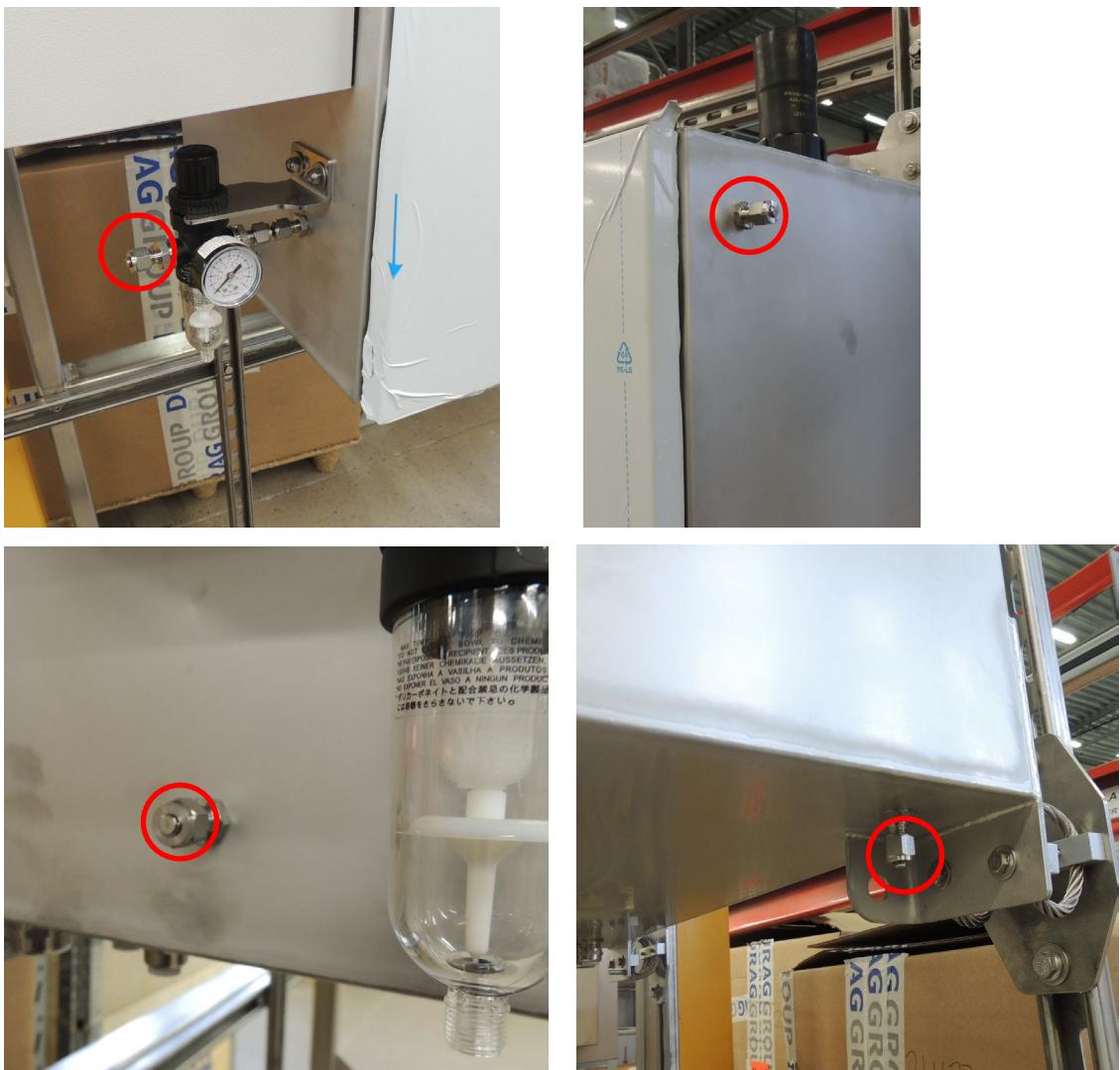

Figure 14 *Plugs on SCC to be removed before start-up*

7.4.2 Signal Exchange list

Request the following document:

→ 50118-D212 *Signal Exchange list*

8 Installation checklist

After the installation has been performed and before SCC is brought into operation for the first time, the checklist described in this chapter must be completed to confirm a correct installation.

It is recommended to set aside time at the end of the installation phase specifically for these tests.

All results from the tests and any remarks to the product or the test results shall be recorded by hand in the accompanying tables.

The installation checklist shall be signed by the installation contractor when completed. This chapter shall then be printed or scanned and be returned to Norsk Analyse prior to commissioning.

Note *Return a scanned copy of the Installation checklist with results and if applicable remarks to Norsk Analyse after installation. Send to service@norskanalyse.com and write the following in the subject field:*

ShipCEMS installation checklist, Project number: 15XXX

Warranty does not apply unless the scanned copy of the Installation checklist is returned to Norsk Analyse.

	Action	Acceptance criteria	Result	Remark
1.	Check that all units have been delivered. Units shall be handled and installed in accordance with GA and details drawings	All units delivered and installed in accordance with GA and details drawings.	<input type="checkbox"/> Accepted <input type="checkbox"/> Not accepted	
2.	Check that the units are not damaged.	No mechanical damages, scratches or dents shall be observed.	<input type="checkbox"/> Accepted <input type="checkbox"/> Not accepted	

	Action	Acceptance criteria	Result	Remark
3.	Check that each unit is accessible for operation and maintenance work.	Verify service access (SCC cabinet door can open completely, necessary access to internal modules, proper lightening etc.).	<input type="checkbox"/> Accepted <input type="checkbox"/> Not accepted	
4.	Check the SCC's vibration mounting.	Verify that the SCC are fastened using proper mounting bolts and tighten. Make sure that the cabinet can move freely on the wire dampers and is not restricted by any cables, tubes etc.	<input type="checkbox"/> Accepted <input type="checkbox"/> Not accepted	
5.	Check the sample probe.	Verify that the spool piece/counter flange is welded to the stack as specified (50118-1202). Verify that the sample probe flange is fastened using proper mounting bolts and tighten. Verify that the probe quill is correctly inserted. Verify that the ceramic filter is mounted and undamaged.	<input type="checkbox"/> Accepted <input type="checkbox"/> Not accepted	
6.	Check the external tubing.	Verify that calibration gas and instrument air is connected as specified. Make sure that the tubing is supported and protected from breakage.	<input type="checkbox"/> Accepted <input type="checkbox"/> Not accepted	

	Action	Acceptance criteria	Result	Remark
7.	Check instrument air.	Verify that instrument air is dry and oil free acc. to ISO 8573-1:2010 class 4.3.4.	<input type="checkbox"/> Accepted <input type="checkbox"/> Not accepted	
8.	Check vents. <hr/> Warning Make sure room is vented! <hr/>	Verify that the atmospheric vent is not restricted.	<input type="checkbox"/> Accepted <input type="checkbox"/> Not accepted	
9.	Check sample out and safety valve outlet on the SCC are vented. <hr/> Warning Make sure room is vented! <hr/>	Verify that plugs are removed.	<input type="checkbox"/> Accepted <input type="checkbox"/> Not accepted	
10.	Check the heated sample line.	Verify that the heated sample line is sufficiently supported, and that the minimum bending radius is adhered to.	<input type="checkbox"/> Accepted <input type="checkbox"/> Not accepted	
11.	Check the heated sample line.	Verify that there are no water traps.	<input type="checkbox"/> Accepted <input type="checkbox"/> Not accepted	
12.	Check for loose fittings.	Check tightness by hand.	<input type="checkbox"/> Accepted <input type="checkbox"/> Not accepted	
13.	Check the electrical cabling.	Verify that all power and signal cables are routed and terminated according to termination and wiring diagrams.	<input type="checkbox"/> Accepted <input type="checkbox"/> Not accepted	

	Action	Acceptance criteria	Result	Remark
14.	Check for loose wires.	Verify that all connections in junction boxes and internal terminal blocks are tight and secure.	<input type="checkbox"/> Accepted <input type="checkbox"/> Not accepted	
15.	Check electrical fuses.	Verify that all equipment is connected to its correct fuse. Verify correct current rating for all fuses.	<input type="checkbox"/> Accepted <input type="checkbox"/> Not accepted	

To be filled in by installation contractor:

Installation contractor	
Ship name / hull no.	
Ship owner	
Checks performed by (date/sign)	
Checks verified by (date/sign)	

9 References

9.1 Drawings

The ShipCEMS drawings below are sent as separate files, prior to delivery.

DWG	Description	230V	120V
Mechanical drawings:			
50118-1001	SHIPCEMS COMPACT HOOK-UP LOCATIONS	X	
50118-1003	SHIPCEMS COMPACT GENERAL ARRANGEMENT	X	
50118-1004	SHIPCEMS COMPACT WIRE DAMPERS ON UNISTRUT	X	X
50118-1202	GENERAL ARRANGEMENT SAMPLE PROBE	X	X
	FLANGES		
System drawings:			
50118-3001	SYSTEM DIAGRAM ANALYSER CABINET GAS FLOW	X	
Electrical drawings:			
50118-5001	TERMINATION DRAWING - OVERVIEW	X	
50118-5002	TERMINATION DIAGRAM POWER DISTRIBUTION	X	
50118-5003	TERMINATION DIAGRAM SIGNAL DISTRIBUTION	X	
50118-5005	TERMINATION DIAGRAM SAMPLE PROBE	X	
50118-5006	OPTION: TERMINATION DIAGRAM CONDENSATE DRAIN TANK ALARM - (OPTION)	X	

Block diagrams:			
50118-6001	SYSTEM BLOCK DIAGRAM P&ID DISTRIBUTION OVERVIEW	X	X
50118-6002	SYSTEM BLOCK DIAGRAM SIGNAL AND POWER DISTRIBUTION OVERVIEW	X	X
Network map			
50118-8201	NETWORK MAP, ShipCEMS Compact (SCC)	X	X

9.2 Documents

DWG	Description	230V	120V
50118-D21	SHIPCEMS COMPACT USER MANUAL	X	X
50118-D212	SHIPCEMS COMPACT SIGNAL EXCHANGE LIST	X	X

10 Installation overview

The overviews on the three following pages are extracts from the termination drawings below as well as fieldbus specification

The extracts should be considered as generic examples.

- [50118-5001] – *TERMINATION DRAWING - OVERVIEW SYSTEM 230VAC STANDARD*
- [50118-5002] – *TERMINATION DIAGRAM 230/120VAC & 24VDC POWER DISTRIBUTION ANALYSER CABINET*
- [50118-5003] – *TERMINATION DIAGRAM SIGNAL PLC/WITH MODBUS TCP/IP ANALYSER CABINET*
- [50118-5005] – *TERMINATION DIAGRAM SAMPLE PROBE*

Note *Always follow the latest revision of the drawing!*

© Norsk Analyse

