



## User Manual

# ShipCEMS Continuous Emission Measurement System



This page is intentionally left blank!



## User Manual

# ShipCEMS Continuous Emission Measurement System

*The purpose of this user manual is to provide the descriptions and procedures required to operate and maintain the ShipCEMS Continuous Emission Monitoring System in a safe and efficient manner. This system is designed for analysis of carbon and sulphur dioxides in wet marine exhaust gas.*

**Revision status**

Revision	Date	Prepared	Checked	Approved
Rev. 09	21.01.2019	ALI	MBA	TESA
Rev. 10	27.02.2019	ALI	MBA	TESA
Rev. 11	04.06.2019	ALI	MBA	TESA
Rev. 12	14.08.2019	ALI	MBA	TESA
Rev. 13	20.12.2019	ALI	MBA	TESA

**Document history**

Revision	Reason for issue
Rev. 09	New parameters in U6 to reduce startup time after power stop. Norsk Analyse logo and part no. Additional span gas mixture. More type approvals. Higher power consumption on SCS due to heater.
Rev. 10	Class NK added to type approvals.
Rev. 11	Cleaning drip tray drain added.
Rev. 12	Prelim. New sample filter 133615 (was 122234). Clarification standard quill. General updates.
Rev. 13	Ref for flow adjustment for calibration, new type approvals, change IP address, checking fans updated.

**Copyright**

© Norsk Analyse

No part of this document may be reproduced, copied, modified or translated in any form or by any means, without the prior written approval from Norsk Analyse.

**Important**

Before using the equipment, read all instructions thoroughly and follow all precautions and warnings contained within this document. Improper use may cause personal injury and/or damage to the equipment and may void the warranty. Norsk Analyse disclaims any responsibility for damage or injury caused by improper installation, use or maintenance of the equipment.

## Table of contents

<b>1</b>	<b>INTRODUCTION.....</b>	<b>10</b>
1.1	Purpose .....	10
1.2	Scope of supply.....	11
1.3	Contact details .....	11
<b>2</b>	<b>GENERAL SAFETY RULES .....</b>	<b>12</b>
2.1	High voltage.....	12
2.2	Hazardous components.....	12
2.3	Heavy equipment.....	12
<b>3</b>	<b>SYSTEM DESCRIPTION .....</b>	<b>13</b>
3.1	Main purpose .....	13
3.2	Sample probe .....	13
3.3	Heated sample line.....	14
3.4	Sample conditioning system, SCS.....	14
3.5	Sample line between cabinets.....	16
3.6	Analyser cabinet, AC.....	16
3.7	Calibration gas.....	18
3.8	Power supply .....	19
3.9	Instrument air supply .....	19
3.9.1	Air filter unit .....	20
3.9.2	Air dryer unit.....	20
3.10	External interfaces.....	21
3.10.1	Standard version.....	21
3.10.2	Interface unit (SC-IU) (option).....	21
<b>4</b>	<b>FUNCTIONAL DESCRIPTION .....</b>	<b>22</b>
4.1	Overview .....	22
4.2	Sample probe and heated sample line.....	23
4.3	Sample conditioning system, SCS.....	24
4.4	Analyser system .....	25
4.4.1	Interface unit, option (SC-IU) .....	26
4.5	Back-purge .....	27
4.5.1	When should back-purge be activated? .....	27

<b>5</b>	<b>OPERATION .....</b>	<b>28</b>
5.1	User interface .....	28
5.2	Modes of operation .....	29
5.2.1	Automatic mode .....	29
5.2.2	Manual mode .....	30
5.2.2.1	LOGO display screen.....	30
5.2.2.2	LOGO display function buttons.....	32
5.3	Operational procedures.....	33
5.3.1	Flow adjustment .....	33
5.3.1.1	Flow adjustment with back-purge activated.....	33
5.3.1.2	Flow adjustment .....	34
5.3.2	Calibration.....	37
5.3.2.1	Flow adjustment for analyser calibration .....	39
5.3.3	Changing calibration interval on the analyser module .....	40
5.3.4	Changing measuring range on the analyser module .....	40
5.3.5	Changing temperature controller settings.....	41
5.3.6	Changing fieldbus address in optional interface unit (SC-IU) .....	41
5.4	Controlled Shutdown .....	42
5.4.1	Start-up after controlled Shutdown.....	42
5.4.2	Maintenance .....	42
5.5	Change IP address in WAGO PLC (AC).....	43
<b>6</b>	<b>TROUBLESHOOTING .....</b>	<b>50</b>
6.1	Troubleshooting philosophy.....	50
6.2	Signals .....	51
6.2.1	Output signals on standard ShipCEMS .....	51
6.2.2	Status signals on Interface unit (SC-IU) using fieldbus .....	51
6.3	Alarms, LOGO unit.....	52
6.4	Information messages, LOGO unit.....	53
6.5	Moisture alarms.....	54
6.5.1	Adjust sensitivity of moisture sensor .....	55
6.6	General troubleshooting procedure.....	57
6.7	Troubleshooting procedures.....	57
6.7.1	Analyser fault.....	57

6.7.1.1	Read log .....	57
6.7.1.2	Delete log.....	58
6.7.2	Visual check, analyser system .....	58
6.7.3	Visual check, SCS.....	59
6.7.4	Functional test, SCS.....	59
6.7.5	Alarm test, SCS .....	59
<b>7</b>	<b>MAINTENANCE .....</b>	<b>60</b>
7.1	Maintenance philosophy .....	60
7.2	Maintenance schedule .....	60
7.2.1	Daily routine .....	61
7.2.2	Weekly routine.....	61
7.2.3	Bi-weekly routine .....	62
7.2.4	Monthly routine.....	62
7.2.5	Routine every six months.....	63
7.2.6	Yearly routine .....	63
7.2.7	Routine every two years.....	64
7.2.8	Routine every three years.....	64
7.2.9	Routine every four years .....	64
7.3	Maintenance procedures .....	65
7.3.1	Replacing or dismantling of internal parts in the analyser module.....	65
7.3.2	Cleaning cabinet exterior and surfaces .....	65
7.3.3	Replacing sample probe filter element.....	66
7.3.4	Replacing sample gas filter element II-type .....	67
7.3.5	Cleaning the drip tray drain .....	68
7.3.5.1	Preventive measures .....	68
7.3.5.2	Cleaning the drip tray drain if water is collected on tray.....	69
7.3.6	Install or replace the calibration gas cylinder.....	70
7.3.7	Emptying the liquid collection tube .....	71
7.3.8	Cleaning T-union.....	71
7.3.9	Replacing dryer tubes (sample gas dryer) .....	72
7.3.10	Particle filter in air filter unit .....	74
7.3.11	Oil absorbing filter in air filter unit.....	74
7.3.12	Replace condense trap .....	75

7.3.13	Replace demister filling – only demister quills.....	76
7.3.14	Cleaning heated sample line.....	77
7.3.14.1	Clean the sample tube.....	77
7.3.14.2	Connect to the spare sample tube .....	77
7.3.15	Leak test.....	78
7.3.15.1	Entire sample line.....	78
7.3.15.2	SCS.....	78
7.3.16	Cleaning of analyser module.....	78
7.3.16.1	HOTSWAP – quick change of analyser module .....	78
7.3.17	Service air dryer.....	79
7.3.18	Replace air cooler fan.....	79
7.3.19	Clean the heatsinks with compressed air.....	80
<b>8</b>	<b>SPARE PARTS LISTS.....</b>	<b>81</b>
8.1	Analyser system .....	81
8.2	Sample conditioning system, SCS.....	87
8.3	Sample probe .....	91
8.4	Calibration gas.....	92
<b>9</b>	<b>TECHNICAL SPECIFICATIONS.....</b>	<b>93</b>
9.1	Environmental requirements.....	93
9.2	Type approvals .....	93
9.3	Measuring range.....	93
9.4	Physical dimensions.....	94
9.5	Materials .....	94
9.6	Ingress protection.....	95
9.7	Maximum temperature SCS and AC.....	95
9.8	Power supply .....	95
9.9	Power consumption .....	95
9.10	Calibration gas (span).....	96
9.11	Instrument air .....	96
<b>10</b>	<b>DRAWING REFERENCES .....</b>	<b>97</b>

## Acronyms and abbreviations

AC	Analyser Cabinet
Back flush	Refer to Back-purge
Back-purge	Cleaning of probe by flushing instrument air through
CEMS	Continuous Emissions Monitoring System
CO <sub>2</sub>	Carbon dioxide
DWG	Drawing
EGCS	Exhaust Gas Cleaning System (scrubber)
GA	General Arrangement (Drawing)
N <sub>2</sub>	Nitrogen
PFA	Perfluoroalkoxy alkane (plastic tube material)
PLC	Programmable Logic Controller
PTFE	Polytetrafluoroethylene (plastic tube material)
SCS	Sample Conditioning System
SO <sub>2</sub>	Sulphur dioxide
SP	Sample probe

## Admonitions

---

<b>Note</b>	<i>Text set off in this manner presents clarifying information or specific instructions relevant to the immediate instruction.</i>
<b>Caution</b>	<i>Text set off in this manner provides a warning notice that failure to follow the directions in this caution can result in damage to equipment.</i>
<b>Warning</b>	<i>Text set off in this manner provides a warning notice that failure to follow the directions in this warning can result in bodily harm or loss of life and/or extensive damage to equipment.</i>
<b>DANGER</b>	<b>TEXT SET OFF IN THIS MANNER PROVIDES A WARNING NOTICE THAT FAILURE TO FOLLOW THE DIRECTIONS IN THIS WARNING WILL RESULT IN BODILY HARM OR LOSS OF LIFE AND/OR EXTENSIVE DAMAGE TO EQUIPMENT.</b>

---

# 1 Introduction

## 1.1 Purpose

The purpose of this user manual is to provide the descriptions and procedures required to operate and maintain the Continuous Emission Monitoring System (ShipCEMS) in a safe and efficient manner.

A thorough understanding of system functions and controls is necessary to optimise overall performance. Careful study of the information in this manual is highly recommended, preferably while exploring the system's various functions.

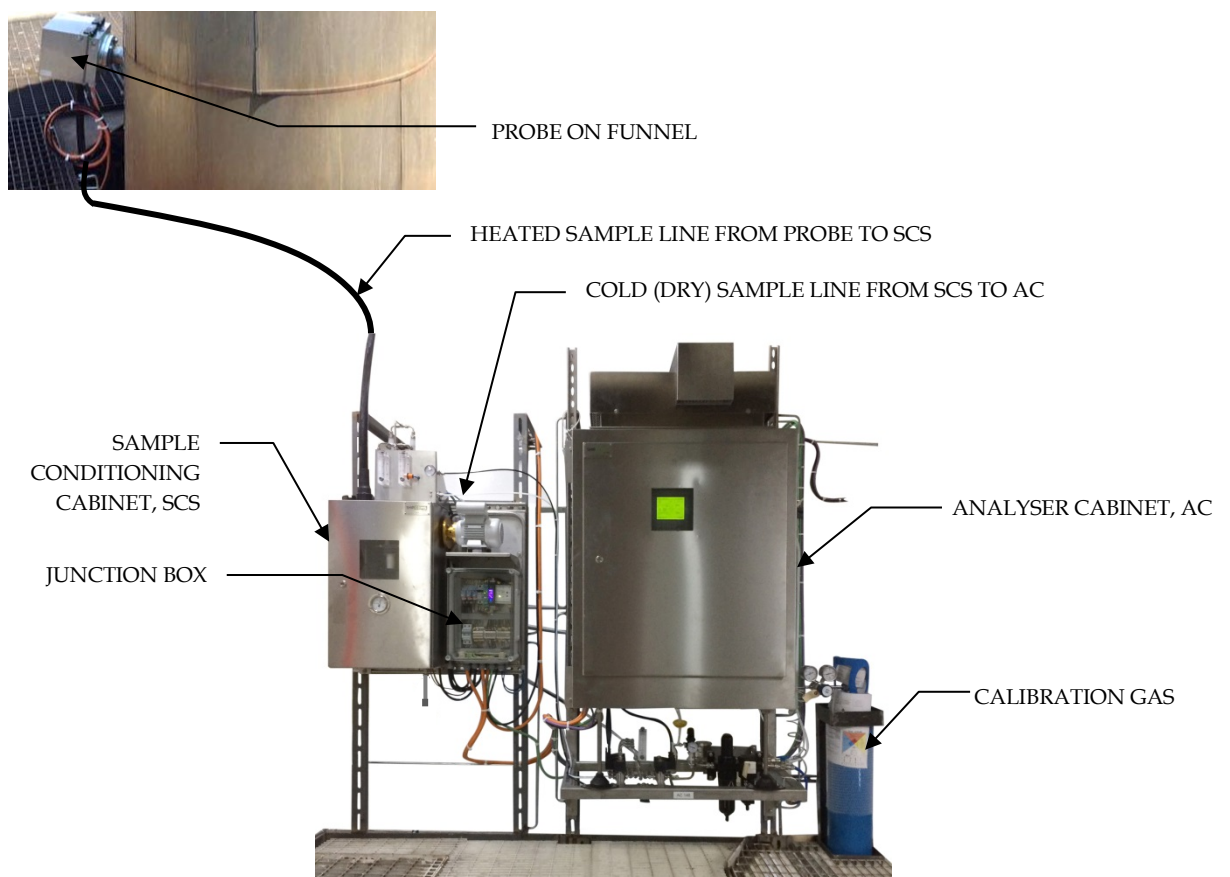

Figure 1 ShipCEMS main parts

## 1.2 Scope of supply

The ShipCEMS consists of the following main units:

- Analyser System cabinet
- Sample Conditioning System cabinet(s)  
- for 1 – 4 streams
- Heated sample probe(s)
- Heated sample line, approximately 10 metres (per sample probe)  
- for 1 – 4 streams
- Optional calibration gases
- Optional air dryer and mounting kit
- Optional air compressor

---

*Note*                      *Equipment provided locally by the installation contractor or by local dealers is not described in this manual.*

*Note*                      *Most of this manual is written as there is one SCS (singular), but there can be up to four SCS to every analyser cabinet (AC).*

---

## 1.3 Contact details

For enquiries related to sales, service, support, maintenance and spare parts, please contact us at:

Norsk Analyse  
P.O. Box 2313, 3103 Tønsberg, Norway  
[www.shipcems.com](http://www.shipcems.com)

Phone: +47 3337 5100  
Fax:    +47 3337 5149

Support:                      [support@norskanalyse.com](mailto:support@norskanalyse.com)

Service:                      [service@norskanalyse.com](mailto:service@norskanalyse.com)

Spare parts:                      [vimex@norskanalyse.com](mailto:vimex@norskanalyse.com)

## 2 General safety rules

Safety precautions must always be followed during installation, operation and maintenance of the system. Personnel shall be sufficiently qualified, and proper caution shall be taken to avoid injuries or damage to life, health, environment, equipment and property.

### 2.1 High voltage

---

**Warning**     *ShipCEMS operates at a potentially lethal AC voltage.*

---

Always switch off all power before installation or maintenance. Adhere to safety precautions and instructions as directed by company policy. For safety reasons during troubleshooting on the equipment with power ON, two persons must always be present.

Whenever installation or maintenance is carried out, it is essential that a first aid kit is available, and that personnel are familiar with the first aid instructions for electrical shock.

### 2.2 Hazardous components

The sample gas may contain trace amounts of hazardous components.

---

**Warning**     *Many toxic gases are colourless, odourless and non-irritating, and may overcome exposed persons without notice.*

---

Personnel should have a thorough knowledge and understanding of the physical properties and safety precautions for the relevant gas samples before operating the system. Gas inlets and outlets are hot in heated analyser systems. Skin contact may result in serious burns even for a long period after the equipment has been switched off.

### 2.3 Heavy equipment

The cabinets are heavy units. Do not open cabinet doors while in rough seas. Doors may suddenly swing open and cause damage or injury.

---

**Caution**     *During installation or replacement of larger units, appropriate safety clothing and certified lifting equipment must be used.*

---

## 3 System description

### 3.1 Main purpose

The main purpose of the ShipCEMS Continuous Emission Monitoring System is to analyse sulphur dioxide and carbon dioxide in wet marine exhaust gas.

ShipCEMS is designed and manufactured for the marine environment, hence ship movements, vibrations and temperature loadings are attended to during design of the system. The sample treatment technology selected is optimised for this specific trace analysis.

ShipCEMS is designed for unmonitored, continuous operation, but all system units may also be manually operated. The user interface is simple and intuitive, with a limited number of operations necessary to use the system.

Self-test diagnosis of analyser maintenance, analyser faults and so on are run periodically. If any test should fail, an error message is sent to the local LOGO display (inside analyser cabinet) and a hardwired alarm signal is also sent to the customer. If a potentially harmful fault occurs, appropriate actions will automatically be taken, for example by shutting down the sample gas pump.

### 3.2 Sample probe

The sample probe with its sample quill (the tube inserted into the exhaust funnel) is installed to extract a representative sample from the exhaust gas of the ship engine. If several engines or combustion processes onboard are to be monitored, one sample probe must be installed per scrubber.

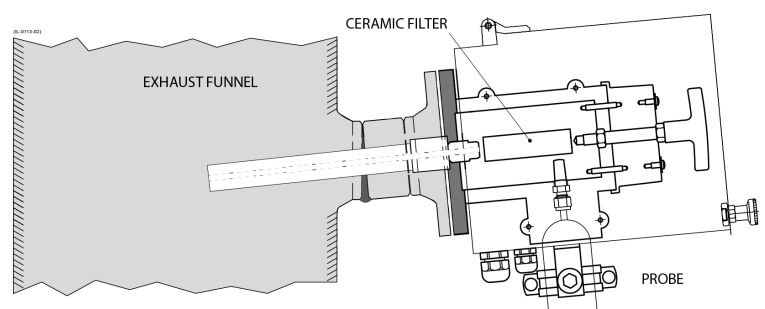

The sample probe is installed onto a connection flange mounted on the exhaust funnel. It is equipped with either a DIN flange DN 65, PN 6, or JIS flange 10K DN65. Other sizes may be delivered if required (including ASTM). The customer must provide the counter flange welded to the exhaust funnel. The quill is attached to the probe and length of the quill determines where in the funnel the sample is extracted from.

Some quills are equipped with demister to remove moisture from the sample gas. Refer to the spare part list in chapter 8.3 for an overview.

The probe is heated to make sure that the sample does not condense when it reaches the 3 micron ceramic filter for separation of dust and other larger particles. The temperature is self-regulating with a low temperature alarm. The sample probe can be equipped with a weather protection hood.

---

**Caution**      *It is important that the sample probe is installed to prevent water traps in the heated sample line. Refer to Installation manual.*

---

### 3.3      Heated sample line

The heated sample line consists of a pre-assembled tube bundle with its own electrical heat tracer cable. An aluminum jacket holds the heat cable and the sample tube together. A high-efficient insulation material is wound around the tracer and the sample tube, and a weather protective outer sheet covers the entire tube bundle. The tube bundle is designed for outdoor installations, but end seals must be used to avoid ingress of moisture.

The size of the tube bundle, the electrical heat tracer and the insulation thickness is based on ambient condition data and exhaust gas composition data.

The heated sample line must always be heated. This prevents condensation and any losses of trace components to be measured. It also avoids expensive and time-consuming maintenance in cleaning the SCS downstream.

In the event of heated sample line power failure, the sample line will cool down. The sample then condensates, allowing heavy soot particles to form and stick to the inner walls of the sample line, as well as contaminating the SCS.

Refer to chapter *Installation procedures* in the installation manual.

### 3.4      Sample conditioning system, SCS

The Sample Conditioning System, SCS, is enclosed by a specially designed cabinet. This cabinet is made of stainless steel SS316L and is mounted to a Unistrut wall frame.

The complete assembly is designed for mounting to a support welded on the ship casing. This support is prepared by the customer, and typically consists of two parallel angled steel bars.

There may be up to four SCS to every analyser cabinet. The main components of the SCS are:

- Heated cabinet
- Sample gas pump
- Sample gas filter
- Sample gas dryers
- Sensors for flow, temperature and moisture
- Junction box
- Flowmeters and regulator. Refer to Figure 8.

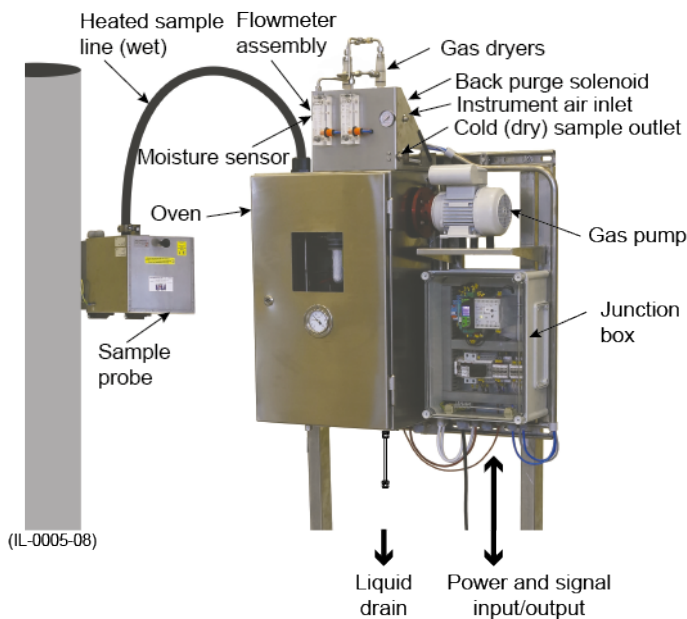

Figure 2 SCS, main units

The purpose of the SCS is to treat and dry the exhaust gas sample extracted by the sample probe via the heated sample line and send it to the analyser cabinet. This sample is wet when it enters, so the temperature needs to be kept above dew point. The sample may contain corrosive components.

The gas pump unit provides a continuous sample flow through the system. The pump converts the sample from suction to pressure mode and moves the sample through the gas dryer tubes.

The permeation dryer tubes are used to remove moisture from the sample by a counter flowing stream of dry instrument air.

The cabinet heater ensures that the heated SCS operates at +60°C to always keep the temperature above dew point. The design temperature of the SCS allows using standard components such as filter elements and a pump head of PFA Teflon.

The junction box contains the temperature controller and the moisture alarm units, as well as a protection switch, fuses, change-over relays and the terminals for 230 VAC power and interfacing I/O signals. The junction box has a connection point to activate the back-purge locally (without signal from SC-IU or signal between analyser cabinet and sample conditioning cabinet). 24 VDC is required to activate the back-purge locally.

SCS alarms are displayed on the LOGO display (located in the analyser cabinet) and it specifies in which SCS cabinet the alarm has occurred. Depending on system there may be up to four SCS cabinets connected to every analyser cabinet. Take action to stop the alarm in specified SCS cabinet. Refer to Figure 5 and Figure 6 for location of LOGO unit.

It is important to adjust flow on recycle gas that goes in a loop through dryer tubes and to adjust flow for dryer air that removes moisture coming from inside the dryer tubes.

---

**Caution**      *If sample is not properly dried and treated it can ruin the analyser!*

---

## 3.5 Sample line between cabinets

The dried sample is then transported from the SCS to the analyser system. As the sample now contains little water, and the dew point temperature is lower than the ambient temperature, PFA/PTFE tubing can be used to interconnect the cabinets.

However, if the ambient temperature is expected to fall below +5°C, it is recommended to use a heated sample line, for example the light heat traced version.

## 3.6 Analyser cabinet, AC

---

**Caution**      *Before the sample enters the analyser cabinet it must be properly treated and dry. Poorly treated sample might cause damage to the analyser!*

---

The analyser cabinet, AC, is enclosed by a specially designed cabinet. This cabinet is made of stainless steel SS316L and is mounted to a Unistrut wall frame with a lower support bracket.

The cabinet is standing on top of two compression cushions to minimise the effects of high gravitational forces when the ship is moving into heavy seas. The cabinet is supported on the rear of the wall frame by soft anti-vibration cushions to reduce the impact of horizontal vibrational movements.

The complete assembly is designed for mounting onto a support structure welded on the ship casing. This support structure is prepared by the customer, and typically consists of two parallel angled steel bars.

The cabinet is insulated with a high-efficient, flame retardant and non-water absorbing synthetic foam to reduce incident heat radiation from ambient conditions and to avoid losing cooled air.

The main components of the analyser cabinet are:

- Online analyser module for analysis of SO<sub>2</sub> and CO<sub>2</sub>
- LOGO PLC with display unit for alarm and auto calibration
- Peltier cabinet cooler system
- Solenoid valves for stream switching, validation and for analyser calibration
- 24 VDC power supply
- 48 VDC power supply (for Peltier cooler only)
- Terminals for power and signal interfaces
- Flowmeter and regulator
- Air filter station
- Optional interface unit (SC-IU)
- Optional air dryer

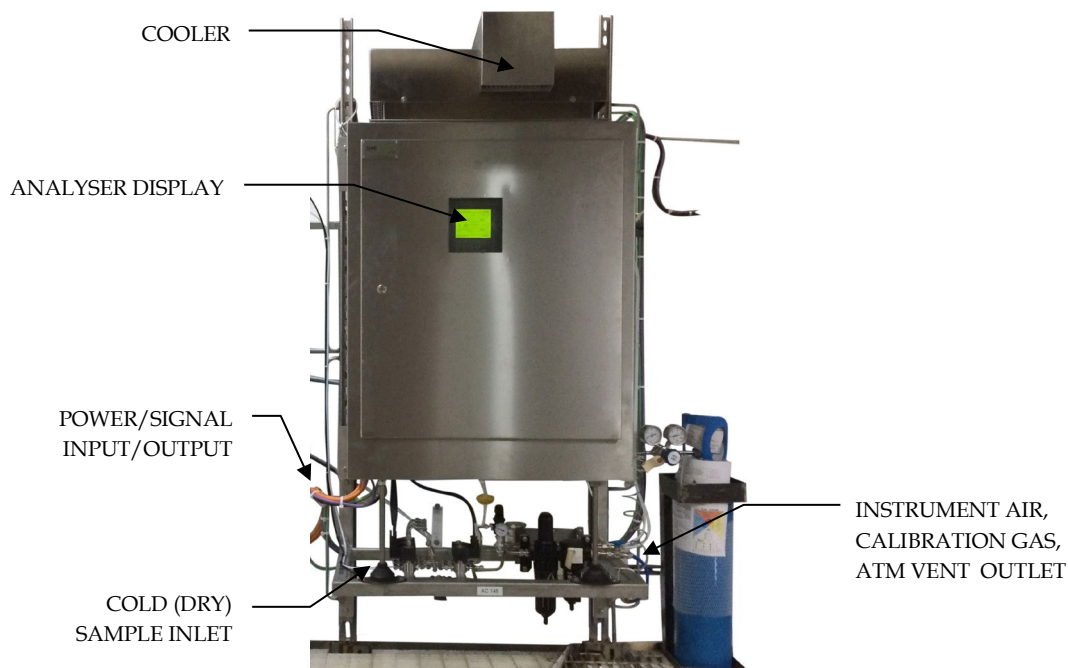

Figure 3 Analyser system, main units

The cabinet door allows access to the analyser and the PLC unit. The door is equipped with an inspection window to enable local measurement readings without opening the cabinet.

The cabinet can be cooled if required by the ambient conditions. The normal ambient temperature is defined as +5°C to +55°C. A Peltier element cooler with 195 W capacity is used to reduce the inside cabinet temperature to maximum +30°C. If the ambient temperature is even higher, a larger air conditioning unit will be used.

The inner cabinet temperature is monitored by a temperature switch set at +30°C. When activated, the temperature switch will power up the 48 VDC/6A power supply feeding the Peltier element. Circuit breaker is 10A. The normal current consumption after start-up <3 A. The current through the Peltier element will draw heat from the surface of one side and heat the opposite side. Both sides have heat exchanger fins mounted.

Both sides also have a separate fan installed. This will draw the internal hot air over the cooled fins for refrigeration and vice versa for the hot side of the element where ambient air is drawn by the hot fan to remove excess heat.

For multi-stream application, only the flowmeter for stream # 1 is adjusted. This serves as an indication for the other streams as well as for calibration gas and instrument air. Refer to chapter 5.3.1 for more information.

### 3.7 Calibration gas

Calibration gas is used for sensitivity verifications as well as calibrations. The 10 litres gas cylinder is the normal use for approx. 30 months.

---

*Note Other cylinders and gas mixtures can be ordered on request.*

---

The recommended calibration gas blends for SO<sub>2</sub>/CO<sub>2</sub> scrubber systems depending on application are:

Part no: 135030	Part no: 125621
<ul style="list-style-type: none"> <li>• 160 ppm SO<sub>2</sub></li> <li>• 8 mol% CO<sub>2</sub></li> <li>• Rest Nitrogen N<sub>2</sub></li> </ul>	<ul style="list-style-type: none"> <li>• 40 ppm SO<sub>2</sub></li> <li>• 8 mol% CO<sub>2</sub></li> <li>• Rest Nitrogen N<sub>2</sub></li> </ul>
Part no: 135142	
<ul style="list-style-type: none"> <li>• 160 ppm SO<sub>2</sub></li> <li>• 12 mol% CO<sub>2</sub></li> <li>• Rest Nitrogen N<sub>2</sub></li> </ul>	

- Other mixtures on request.

It is normally enough only to have one calibration cylinder onboard.

Note that instrument air supplied by the ship is used for zero calibration.

## 3.8 Power supply

The customer must provide a continuous power supply 230 VAC, 50/60 Hz two-phase. Each cabinet is protected using a main two-pole incoming fuse.

120 V can be provided as option.

---

*Note*                      *Equipment start-up after blackout or restart is only 1-2 minutes, when the system is warm.*

---

## 3.9 Instrument air supply

The customer must provide quality instrument air supply, with a water dew point of less than  $-17^{\circ}\text{C}$ , and with no oil and no particulate contaminants. This is vital for the SCS to function correctly. Also, low air quality cannot be used for zero gas verifications of the analyser. Absorbent chemical seals to avoid oil passing into the analyser system, must also be included.

Air requirements:

- Dry, oil-free according to ISO 8573-1:2010 [4: 3: 4] (@ outlet instrument air).

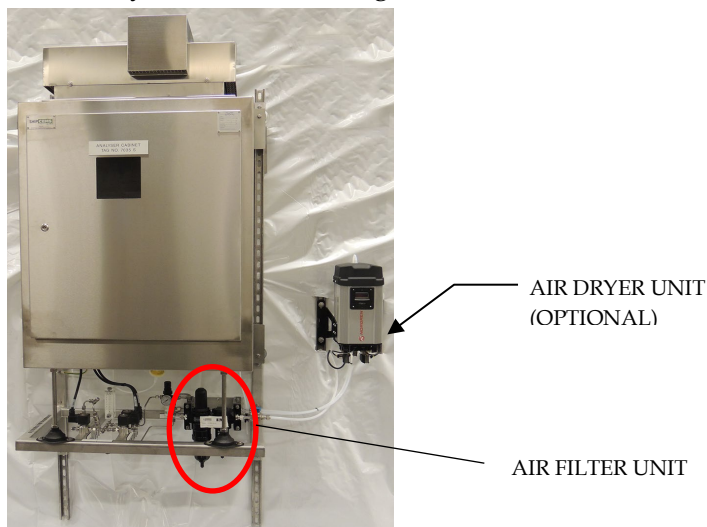

### 3.9.1 Air filter unit

The analyser cabinet is delivered with an air filter unit (SC-AF) for removal of particles, water and oil. The air filter unit is mounted just after instrument air inlet connection on the analyser cabinet frame.

### 3.9.2 Air dryer unit

If the instrument air on the vessel does not meet the air requirements above an optional air dryer unit can be installed. The air dryer unit is normally mounted next to the analyser cabinet.

Part no:	Material description
126414 (SC-AD)	ShipCEMS - Air dryer unit 1-2 streams
129047 (SC-ADH)	ShipCEMS - Air dryer unit 3-4 streams
131844	ShipCEMS - Air dryer unit Mounting Kit

## 3.10 External interfaces

Analyser readings of gas component values and system alarms generated by ShipCEMS are hardwired to the external customer monitoring and reporting systems.

Signal interfaces are located at the upper left-hand corner of the analyser cabinet.

If the customer needs to control multi stream switching for a multi-funnel application, there is a specific signal interface terminal for the LOGO PLC located at the upper right-hand corner of the analyser cabinet.

### 3.10.1 Standard version

The following signal interfaces are available:

- Analogue outputs
  - 1 x 4 – 20 mA for CO<sub>2</sub> measurements
  - 1 x 4 – 20 mA for SO<sub>2</sub> measurements
- Digital outputs
  - SCS common alarm (general fault)
  - AC alarm
  - Measurement valid
  - Maintenance in progress

The analogue signals from ShipCEMS are active and isolated outputs.

The digital signals open or close relays in the LOGO PLC according to the table below.

Signal	Signal type	Open relay	Closed relay
SCS common alarm	Alarm	Alarm or power off	No fault
Analyser failure	Alarm	Alarm or power off	No alarm or maintenance request from analyser
Measurement valid	Information message	Not valid or power off	Valid measurement
Maintenance in progress	Information message	No maintenance or power off	Maintenance or calibration in progress true

### 3.10.2 Interface unit (SC-IU) (option)

The interface unit uses Profibus or Modbus communication to communicate with Scrubber Automation System. For detail see:

→ *NA-E-SPC-068 ShipCEMS Fieldbus Specification*

# 4 Functional description

## 4.1 Overview

This chapter gives a brief description of the functional design of the analyser system. The flow of the gas sample is described from the exhaust gas sample point until the processed readings are presented to the customer's workstation.

ShipCEMS is designed to measure low values of carbon and sulphur dioxide components in wet marine exhaust gas. The exhaust gases are also normally dirty, with a high content of soot. Trace components can easily be lost in the sample treatment system before arriving at the analyser instrument, resulting in improper readings. The ShipCEMS design is therefore based on heated sample treatment to avoid these defects, hence measuring the true gas composition.

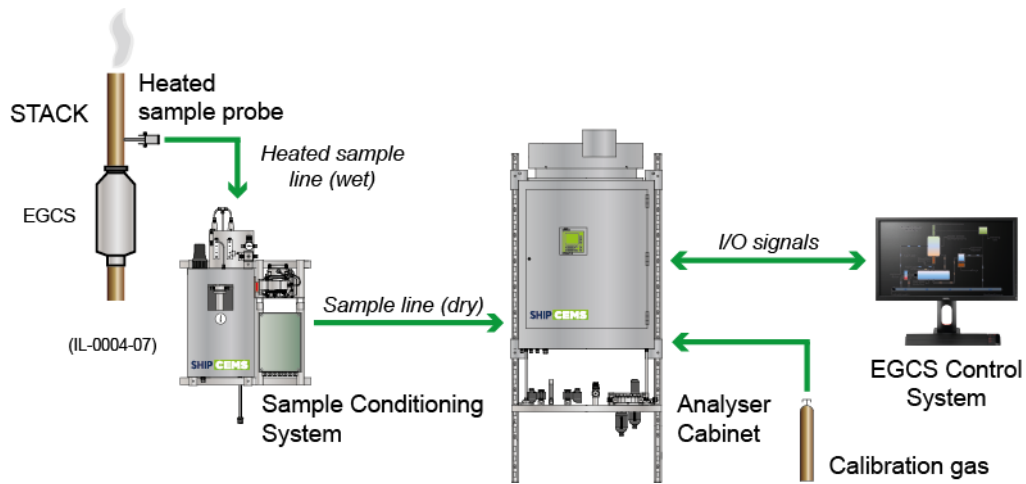

Figure 4 Block diagram for ShipCEMS analyser system

If the customer needs to control multi stream switching for applications with several exhaust funnels, one sample probe is provided for each of the exhaust funnel with a belonging sample conditioning cabinet and heated sample line. A maximum of four sample conditioning cabinets can be supported by one analyser cabinet.

For a full understanding of this functional description chapter, please examine the following system drawings in parallel:

- [3001] – SYSTEM DIAGRAM ANALYSER CABINET (AC)
- [3002] – SYSTEM DIAGRAM SAMPLE CONDITIONING SYSTEM (SCS)
- [5003] – TERMINATION DIAGRAM SIGNAL DISTRIBUTION / INTERFACE ANALYSER CABINET (AC)
- [6001] – SYSTEM BLOCK DIAGRAM P&ID DISTRIBUTION OVERVIEW
- [6002] – SYSTEM BLOCK DIAGRAM SIGNAL AND POWER DISTRIBUTION OVERVIEW

Note that labelling of all individual components described, for example needle valve NV-1, conforms to labels in the corresponding system drawing.

## 4.2 Sample probe and heated sample line

The sample probe (with quill) is installed to extract a representative sample from the exhaust gas.

The heated sample line requires 230 VAC power supply. A self-regulating heat tracer cable is used to set temperature above dew point to avoid condensation.

---

*Note*                      *In event of a power failure, the sample probe will cool down. If this occurs, a low temperature alarm output signal is generated and sent as an SCS Common Alarm to the analyser cabinet and the scrubber automation system.*

---

The alarm (visible on the LOGO display) will warn if wet and cold samples are extracted into the system. As a safety precaution, the sample gas pump is always stopped if the temperature is too low.

## 4.3 Sample conditioning system, SCS

The gas sample from the exhaust funnel enters the heated SCS, first passing through the filter assembly for removal of particulate matters. To ensure a continuous sample flow, gas pump is needed. The pump will convert the sample from suction to pressure mode and transport the sample through the gas dryer tubes.

Moisture is removed in the dryer tubes by a counter flowing stream of dry instrument air. (The air is harmless and is released in the SCS.)

The customer provides the instrument air inside the SCS for air circulation (according to **ISO 8573-1:2010 class 4.3.4**), which must have a low dew point and be free of oil. The necessary inlet air pressure of 1 barg is set by the pressure regulator, and the flow is set to approximately 10 l/min using needle valve NV-1 (in the SCS). The flow is monitored by flow indicator FI-2 (in the SCS).

---

*Note*                      *If the instrument air flow drops below set point, a low-level flow alarm is generated. This alarm will also shut down the gas pump.*

---

The partial pressure of water in the sample on one side of the membrane will drive the water molecules through the membrane to the counter flowing stream of low partial pressure air. The membrane is chemically treated with Nafion for polar water transmission only. There are no other trace component losses in the permeation tube dryer, except for small losses of ammonia, if present.

The dry sample on the outlet of the membrane dryer will be recycled to the inlet of the SCS. The flow is set to approx. 3 NI/min. since the pump capacity is approx. 5 NI/min, the excessing 2 NI/min will be transferred to the analyser. This means that the analyser always has a fresh sample close to the analyser.

The dry sample on the outlet of the membrane dryer will be recycled to the inlet of the SCS. The flow is set to approximately 5 NI/min using needle valve NV-2. This reduces the dew point, and hence reduces the temperature requirement for the heated SCS. The blend of incoming wet sample and the dried sample will allow the heated SCS to be operated at +60°C. The recycle flow is monitored by flow indicator FI-1(in the SCS).

To protect the system against moisture, a moisture sensor is installed downstream the gas dryers.

---

*Note*                      *If a moisture alarm is generated, the sample shut off valve will close. This will also lead to a low flow alarm from the analyser cabinet side.*

---

The system will then close the SCS sample outlet and run the sample in recycle mode until all moisture is removed. In case of large errors, the system can be cleaned using instrument air by a manual operation.

---

*Note*                      *The temperature inside the heated SCS is monitored. If the temperature drops below +55°C, a low temperature alarm is generated and sent as a SCS Common Alarm to the analyser cabinet and the scrubber automation system. This alarm will also shut down the gas pump.*

---

All alarms will generate a common SCS alarm hardwired to the analyser cabinet. These common alarms are also displayed in the LOGO display.

## 4.4            Analyser system

The dried gas sample will now enter the analyser system. Needle valve NV-2 (located in the SCS) is used to set the sample flow to the analyser to approximately 1 NI/min.

This can be monitored by flow meter FI-11 in the analyser cabinet, AC.

---

*Caution*                *Only adjust flow on the NV-2 in the SCS.  
Do not use the NV-1.1 in the analyser cabinet.*

---

After being processed by the analyser module, the sample is released to ambient air through the atmospheric vent.

For a multi-funnel application, one of the stream-switching solenoid valves must be opened by the LOGO PLC to allow a sample to enter. Up to four streams may be handled by the system, but only one sample will be analysed at a time. This is set by the Select Engine #1 (or #2, #3 or #4) signals controlled by scrubber automation system. For a single stream system, only Select Engine #1 will be used.

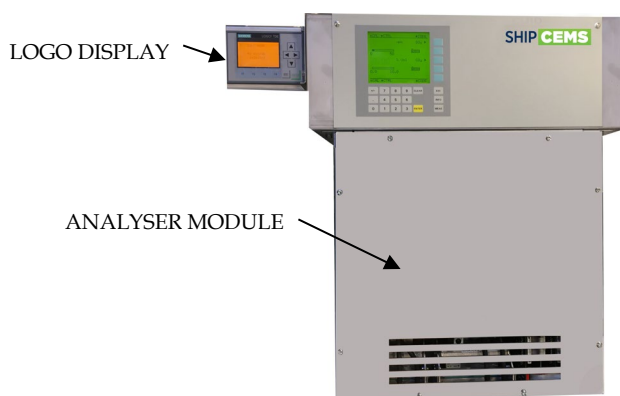

*display (inside analyser cabinet)*

The analyser cabinet includes both the analyser module and the LOGO PLC controller unit. Both instruments are supported by a specially designed bracket inside the cabinet.

The analyser module is a dual-channel analyser used to measure SO<sub>2</sub> and CO<sub>2</sub>. The analyser operates according to the infrared two-beam alternating light principle with double-layer detector and optical coupler.

*Figure 5            Analyser module and LOGO*

The measuring principle is based on the molecule-specific absorption of bands of infrared radiation, as the absorbed wavelengths are characteristic to the individual gases. The detector layers will record the level of absorption, which then will be converted into an electric signal by a flow sensor. The values recorded are continuously presented to the customer's external control and monitoring systems (scrubber automation system) by 4 - 20 mA analogue output signals for each gas component. For optional interface unit (SC-IU) the values recorded are presented by fieldbus communication.

The LOGO PLC is a simple programmable logic controller for control of stream valves, validation and calibration valves, as well as for calibration of the analyser. The unit will also warn if any alarm conditions occur, via its local display - the LOGO display - and remotely by hardwired signals to the scrubber automation system.

#### 4.4.1 Interface unit, option (SC-IU)

This PLC is an option for customers who want to connect systems using one modbus/profibus cable instead of several digital and analog cables. The interface unit converts ShipCEMS digital and analog signals to a protocol and thereby provides a fieldbus connection.

With the interface unit back-purge is controlled via PLC.

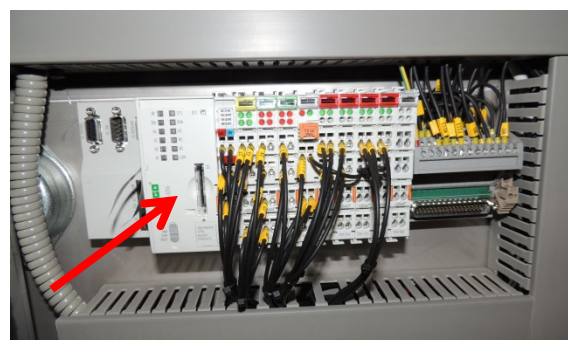

SC-IU option offers an intelligent control box for ShipCEMS system to facilitate system integration. SC-IU offers Profibus and Modbus as standard fieldbus connection, while others are available on request.

SC-IU will facilitate communication to/from Scrubber Automation System as it will automatically separate measured values into RAW values and individual stream values. SC-IU also automatically calculates the ratio  $SO_2/CO_2$ . This makes it much easier to generate emission reports directly from the ShipCEMS data.

Stream switching sequence for multi stream systems are controlled by SC-IU. Alarm signal will be transferred over fieldbus connection if IMO regulations cannot be met with respect to ratio limit and time limit for next sample.

SC-IU runs a webservice application which can be accessed by a standard internet browser. This is a very useful tool when troubleshooting the system. It can also easily connect to ship Scrubber Automation System for real time status and system overview.

For connection, refer to *Installation manual chapter 7.4.3* or the following document:

→ *NA-E-SPC-068-02 Fieldbus Connection (AC)*

## 4.5 Back-purge

Back-Purge is activated from scrubber automation system

Back-purge is installed on all systems. It is very important that back-purge is activated when scrubber is off or in cleaning mode. The reason for this is to protect the analyser unit from raw gas from the exhaust funnel. Back-purge can be either manual or automatic (SC-IU).

The back-purge solenoid valve is in the SCS cabinet.

Purging the line with air will reduce the need for maintenance of the probe as well as protect the system from raw gas. Instrument air is used as purge medium. The criteria for back-purge are set by the customer. The ShipCEMS system is back-purged as follows:

- **Standard (without SC-IU option):**

Without the SC-IU option the back-purge signal needs to be activated by scrubber automation system immediately-when scrubber is off or in cleaning mode.

Back-purge is activated in the SCS junction box, terminal X1-115 and X1-116.

- **SC-IU option:**

The signal for scrubber in operation from client is used by SC-IU to control this back-purge solenoid valve. Sample collection is then stopped, and instrument air is now allowed to flow upstream through the sample probe into the exhaust funnel.

The ShipCEMS system will activate back-purge automatically when the select engine signal is deactivated when using the interface option.

### 4.5.1 When should back-purge be activated?

- When scrubber is off (to prevent raw exhaust from entering the sample lines).
- When scrubber is ready – normally when temperature < 40-80°C.

---

*Note Lower temperatures require less frequent filter change and maintenance in general.*

---

- When scrubber is in cleaning mode/demisting.
- During demister cleaning, soot-blowing, nutshell cleaning, wash water cleaning and other cleaning of funnel.
- When the back-purge is activated when scrubber is in dry-mode i.e when scrubber not in operation (or engine not selected).

---

*Note Back-purge signal must be de-activated before “Select engine signal” from scrubber in operation is activated. Sampling can now start.*

---

# 5 Operation

---

*Note*            *The time from start-up to ready system is approx. 45 minutes.*

*Note*            *Start-up after power break (when the system is warm) is only 1-2 minutes.*

---

## 5.1 User interface

The operator can interact with ShipCEMS using the following external systems and instruments:

- Scrubber automation system
- Analyser module
- LOGO unit
- SC-IU webserver application (expert users, optional)

ShipCEMS will send analyser readings, alarms and information messages for remote monitoring on the scrubber automation system. It is the responsibility of the customer to configure the scrubber automation system, as this control system is not a part of the ShipCEMS delivery.

The analyser and the LOGO instruments in the analyser cabinet are operated using front panel displays and control buttons.

The analyser module is used for reading of real-time measurements, whilst the LOGO display is used for menu operation when running manual maintenance and calibration operations. The LOGO PLC is also responsible for sending alarm and information messages to the scrubber automation system.

Contact Norsk Analyse for information about advanced functions in the analyser module.

## 5.2 Modes of operation

### 5.2.1 Automatic mode

Under normal conditions, the ShipCEMS is designed to operate fully automatic.

Sample analysis is performed continuously. The measured values of SO<sub>2</sub> (in ppm) and CO<sub>2</sub> (in mol %) as well as the ratio are sent to the operator (scrubber automation system) as fieldbus variables.

---

*Note*                      *Automatic calibration in this context means that the system will control all solenoid valves and calibration cycle automatically. The automatic calibration cycle still needs to be started manually. See chapter 5.2.2 for details.*

---

During automatic calibration the digital signal (*Maintenance in progress*) is set high. This will notify the operator (scrubber automation system) that calibration is running.

---

*Caution*                      *Even though the system is in automatic mode, manual calibration is necessary to calibrate the analyser module. To be in compliance with the type approval certificate issued for this analyser, manual calibration needs to be performed every 30 days. Norsk Analyse recommends verification every two weeks to make sure the analyser is accurate at all time.*

---

## 5.2.2 Manual mode







Figure 6 LOGO display

The LOGO unit holds four front panel control buttons; F1 to F4 for manual operation. Compared to the previous model LOGO TDE has a colour display; yellow to signal status and red to signal more serious matters or when it is necessary to act.

### 5.2.2.1 LOGO display screen

**Caution** Act when LOGO display is red. Negligence can affect the analysis.

Screen	Description
	<p><b>IDLE MODE - No stream selected</b></p> <p>This mode signals that either...</p> <ul style="list-style-type: none"> <li>no stream has been selected for measurement. Select stream! "AC alarm" is suppressed</li> <li>or that scrubber is not running. In this case there is usually a communication error in the scrubber automation system.</li> </ul>
	<p><b>MAINTENANCE MODE - F1</b></p> <ul style="list-style-type: none"> <li>This mode signals that automatic calibration is running. PLC returns automatically to "IDLE MODE".</li> <li>Manual maintenance procedures (e.g. filter change). The operator presses F1 to start maintenance. Press F1 to exit and return to "IDLE MODE".</li> </ul> <p>Also refer to function buttons in chapter 5.2.2.2.</p>

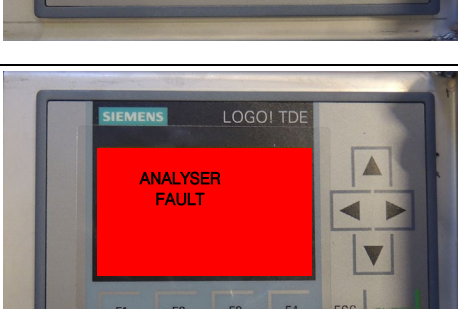
Screen	Description
	<p><b>SPAN CHECK - F2</b></p> <p>F2 starts span by opening the cal gas solenoid. Timer will display duration of span check. When analyser values are stable, compare results with the calibration gas certificate.</p> <p>Also refer to Function buttons in chapter 5.2.2.2.</p>
	<p><b>CALIBRATION MODE - F3</b></p> <p>F3 performs flow adjustment according to 5.3.1 before AUTO CAL.</p> <p>F3 starts automatic calibration cycle. Once the calibration cycle is started it cannot be stopped.</p> <p>If calibration fails analyser fault is triggered. (Successful calibration is not reported.)</p> <p>Also refer to function buttons in chapter 5.2.2.2.</p>
	<p><b>SERVICE MODE - F4</b></p> <p>F4 is used to control the solenoids manually. Refer to text below.</p> <p>Also refer to function buttons in chapter 5.2.2.2.</p>
	<p><b>ANALYSER FAULT</b></p> <p>This mode signals that the analyser is not working correctly.</p> <p>Refer to section 6.7.1 or contact Norsk Analyse.</p>

### 5.2.2.2 LOGO display function buttons

#### F1 - Maintenance mode

This button is used to send a message to the scrubber automation system that maintenance is performed on the system. In maintenance mode the Measurement valid signal will be suppressed. This will enable the operator to filter measurements when performing system maintenance.

Press F1 to enter maintenance mode.

Press F1 once more to exit maintenance mode.

---

*Note*                      *Function F1 should only be used when troubleshooting or rectifying the system.*

---

#### F2 - Span check

This button is used to perform a span check of the analyser module.

Use the F4 button on the LOGO display to check that flow is 1 l/min on span and air. If flow is not within range, perform flow adjustment according to chapter 5.3.1.

Press F2 to start span check. This will open for span gas to the analyser for two minutes.

Press F2 once more to stop span check. This can be done if the analyser reading stabilises before the two-minute period has elapsed.

If the deviation between the analyser reading and the calibration cylinder certificate is larger than 5 %, a calibration of the analyser should be performed. Refer to chapter 5.3.2.

#### F3 - Calibration mode

Prior to using the F3 button on the LOGO display, press the F4 button to check that flow is 1 l/min (F4) on span and air. If flow is not within range, perform flow adjustment according to chapter 5.3.1.

The F3 button is used to trigger automatic calibration. Once the button is pressed, the system will perform automatic calibration. When completed, the system will automatically return to its normal measuring mode.

#### F4 - Service mode

This button is used to control the solenoid valves manually. Press once to enter the service mode. Press F4 to toggle through the solenoid valves, opening them one by one. The complete cycle, ending with solenoid valve S6, must be toggled through before returning to the normal operational mode.

The following solenoid valves are available:

- S1 to S4 - Sample stream 1 to 4 to analyser system
- S5 - Calibration gas to analyser system
- S6 - Instrument air to analyser system

---

*Note*                      *Function F4 is dedicated to system testing and should only be accessed by advanced users.*

---

## 5.3 Operational procedures

As ShipCEMS is designed to operate fully automatic, only a limited number of procedures are applicable during normal system operation.

---

**Caution**      *Do not access the analyser module menu for other purposes than listed in the following, as unskilled operation may result in system malfunction or equipment damage.*

---

### 5.3.1 Flow adjustment

Depends on scenario:

- A. If ShipCEMS system is not running and back-purge is activated:  
Follow first instructions in chapter 5.3.1.1 and then instructions in chapter 5.3.1.2.
  
- B. Is scrubber, ShipCEMS system is running and back-purge is deactivated on all SCS?  
Follow instructions in chapter 5.3.1.2 (skip chapter 5.3.1.1).

#### 5.3.1.1 Flow adjustment with back-purge activated

Verify scenario A in chapter 5.3.1.

---

**Note**      *This start-up procedure is applicable when scrubber is off. This is to prevent false alarms and will set up the system to give correct measurement during analysing.*

---

When starting flow adjustment follow the steps below:

- 1) Make sure scrubbers are off and that back-purge is activated.
- 2) Turn off the power for the analyser cabinet and all SCS cabinets (two circuit breakers in the analyser cabinet and two circuit breakers SCS cabinet).
- 3) Disconnect the heated sample line from T-piece in all SCS cabinets. Refer to Figure 7.



Figure 7      *T-piece in the SCS cabinet*

- 4) Disconnect cable in SCS junction box from terminals X1-115 and X1-116 (back-purge activation signal).
- 5) Isolate the cables from X1-115 and X1-116 using tape or other safe material. Make sure that they are separate.

- 6) Switch on the two circuit breakers in the analyser cabinet and two circuit breakers SCS cabinet.
- 7) Perform a flow adjustment for the entire system according to chapter 5.3.1.2.
- 8) Startup adjustment is now completed.
- 9) Turn off power for the analyser cabinet and SCS cabinets in the junction box in the SCS (two circuit breakers for the analyser cabinet and two circuit breakers for SCS cabinet).
- 10) Reconnect the heated sample line to the T-piece in the SCS cabinet. Refer to Figure 7.
- 11) Reconnect the cable in SCS junction box to terminals X1-115 and X1-116 (back-purge activation signal).
- 12) Turn on the system by switching on the two circuit breakers in the analyser cabinet and two circuit breakers SCS cabinet.
- 13) Wait for the system to warm up. It takes approx. 45 min to 1.5 hours depending on climate and surrounding cooling.
- 14) Perform calibration. Refer to chapter 5.3.2.
- 15) System is ready for use and scrubber can be started.

### 5.3.1.2 Flow adjustment

Verify scenario B in chapter 5.3.1.

It is important that the flow settings are correctly adjusted to prevent flow alarm and damaging the analyser.

---

**Caution**      *Incorrect flow setting might damage the analyser.*

---

**Flowmeters** (refer to Figure 8 and Figure 9):

- On SCS: FI-1, Recycle gas:            3-4 l/min
- On SCS: FI-2, Dryer air:            Min. 10 l/min
- On AC: FI-11 (under cabinet):      1 l/min

**Regulators:**

- On SCS:                            1 barg
- On AC:                            0.5-1 barg, depending on sample gas flow from SCS
- On Gas cylinder:            0.3-0.6 barg, depending on sample gas flow from SCS

**Flow adjustment procedure:**

- 1) AC (analyser cabinet): Turn on the circuit breaker (item 2 and 4 on dwg 1003).
- 2) AC: Open valve, BV-1, on air supply (under AC). Refer to Figure 9.

- 3) SCS (sample conditioning system): Adjust air pressure regulator (for air supply) in Figure 8 to 1 barg.
- 4) SCS: Adjust flowmeter FI-2 Dryer air (right flowmeter) to minimum 10 l/min on all applicable SCS. Refer to Figure 8.
- 5) Wait for the system to warm up (approx. 30 min in room temperature).
- 6) AC: Press the F4 button on the LOGO display (PLC, item 14 on dwg 1003) until stream 1 is selected.
- 7) SCS: Adjust flowmeter FI-1 Recycle gas (left flowmeter on picture) to 3 l/min on stream 1. Refer to Figure 8.



Figure 8 Flowmeters and regulator on SCS

- 8) AC: Make adjustment on flowmeter, FI-11, under AC to approx. 1.0 l/min when stream 1 is selected. Refer to Figure 9.

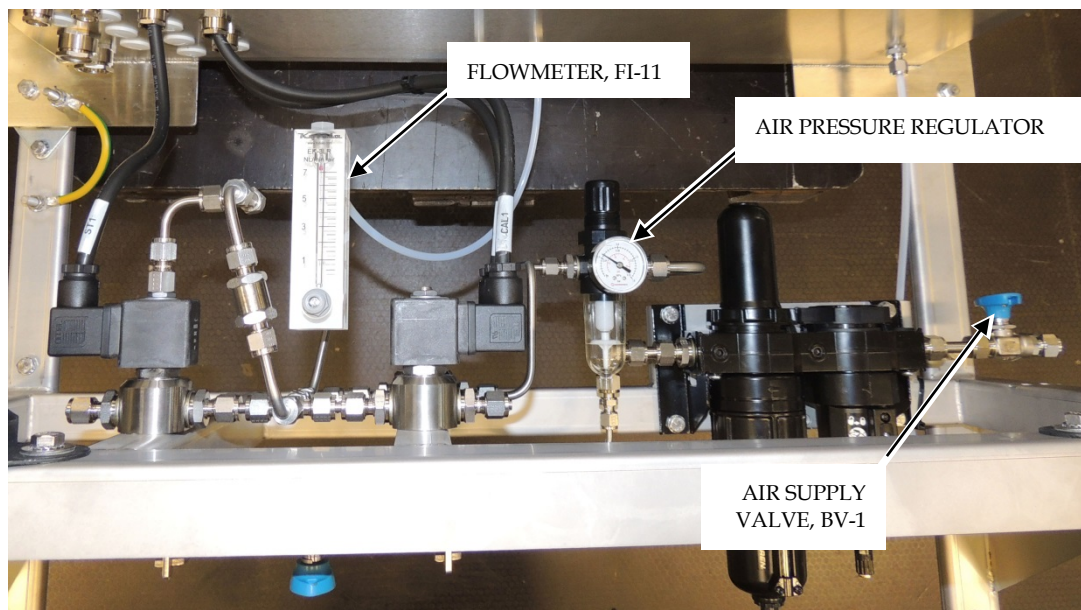

Figure 9 Flowmeter, regulator and air supply valve under AC

- 9) If stream 2 is installed:  
Press the F4 on the LOGO display until stream 2 is selected. Adjust the flowmeter **FI-1 (SCS)** on stream 2 so that flowmeter FI-11 (AC) is approx. 1.0 l/min.

---

**Caution**      *For streams 2-4 when installed:  
Do not adjust flowmeter FI-11 under AC!  
Adjust only the flowmeter FI-1 on the SCS.*

---

- 10) If stream 3 is installed:  
Press the F4 button on the LOGO display until stream 3 is selected.  
Adjust the flowmeter **FI-1 (SCS)** on stream 3 so that flowmeter FI-11 (AC) is approx. 1.0 l/min.
- 11) If stream 4 is installed:  
Press the F4 button on the LOGO display until stream 4 is selected.  
Adjust the flowmeter **FI-1 (SCS)** on stream 4 so that flowmeter FI-11 (AC) is approx. 1.0 l/min.
- 12) AC: Press F4 button on the LOGO display until *Air inlet* is selected.
- 13) AC: Adjust the air supply pressure regulator under AC (refer to Figure 9) until flowmeter, FI-11, under AC is 1.0 l/min.
- 14) Make sure the gas regulator (refer to Figure 10) is fully closed.  
(Fully turned counterclockwise.)

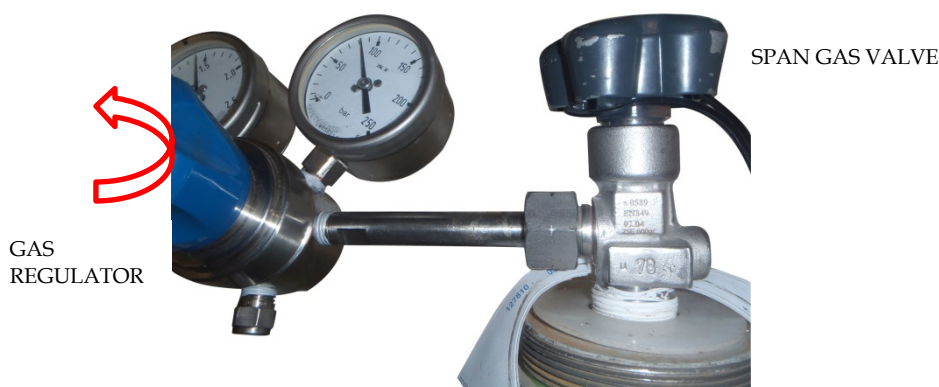

Figure 10      *Valve and regulator on span gas cylinder*

- 15) AC: Press F4 button until *Span inlet* is selected.
- 16) Open span gas valve on the cylinder and carefully open gas regulator (several turns clockwise) until flowmeter, FI-11, under AC (refer to Figure 10) shows 1.0 l/min.
- 17) Flow settings are completed.
- 18) Close both gas regulator and span gas valve.

## 5.3.2 Calibration

---

**Caution** *Even if the system is in automatic mode, manual calibration is necessary to calibrate the analyser module. To be in compliance with the type approval certificate issued for this analyser, the manual calibration needs to be performed every 30 days. Norsk Analyse recommends verification every two weeks to make sure the analyser is accurate at all time.*

---

The standard ShipCEMS system analyses SO<sub>2</sub> and CO<sub>2</sub>. Over time the analyser may drift and subsequently present slightly incorrect values of SO<sub>2</sub> and CO<sub>2</sub> content. Therefore, the analyser may need calibration.

### ZERO CALIBRATION:

- During zero calibration for SO<sub>2</sub>, a reference gas with no SO<sub>2</sub> (e.g. instrument air) is used to make a new zero reference for the analyser. (Enter 0ppm into the analyser.)
- During "zero" calibration for CO<sub>2</sub>, a reference gas with only 0.04% CO<sub>2</sub> (instrument air) is used to make a new "zero" reference for the analyser. (Enter 0.04 into the analyser.)

The analyser module is zero calibrated using instrument air supplied through analyser cabinet inlet nozzle N5.

During calibration, the streaming solenoid valve will be closed and will stop sample gas, whilst simultaneously opening the zero gas solenoid valve. Both solenoid valves are controlled by the LOGO PLC. (Check the calibration gas blend on the cylinder and enter values into the PLC.)

### SPAN CALIBRATION:

- During span calibration for SO<sub>2</sub> and CO<sub>2</sub>, a reference gas with a mixture of SO<sub>2</sub> and CO<sub>2</sub> (calibration gas from the cylinder) is used to make a new span reference for the analyser. (Enter blend concentration from the calibration gas cylinder into the analyser.)

The analyser module is span calibrated using span gas supplied through analyser cabinet inlet nozzle N6. During calibration, the streaming solenoid valve will be closed, stopping sample gas, whilst simultaneously opening the span solenoid valve. Both solenoid valves are controlled by the LOGO PLC.

## CALIBRATION PROCEDURE:

- 1) Make sure flow adjustments are carried out according to 5.3.2.1.
- 2) Press the F3 button on LOGO display to start the auto-calibration procedure below:

### **Zero calibration:**

- 3) **Prior to** zero calibration the solenoid valve for instrument air will open and the analyser will be purged with air for two minutes for stable reading. Purging is performed automatically.
- 4) When readings are stable the zero calibration is performed.
- 5) Solenoid valve for instrument air will close and span calibration will start.

### **Span calibration:**

- 6) Prior to span calibration the solenoid valve for span gas will open and the analyser will be purged with span gas for two minutes for stable reading. Purging is performed automatically.
- 7) When readings are stable, the span calibration is performed.
- 8) After span calibration is performed the solenoid valve will close and the system goes automatically back to its prior mode (e.g. measuring or idle mode).
- 9) Close span gas valve on the cylinder.

---

*Note*                      *Purging is performed to achieve stable measurements before calibration.  
A complete calibration procedure takes approx. four minutes.*

---

The system is designed to operate fully automatic, so the LOGO PLC will control the solenoid valves automatically. It is however possible to manually control the solenoid valves with function F4 service mode. Refer to chapter 5.2.2.

### 5.3.2.1 Flow adjustment for analyser calibration

- 1) AC: Press F4 button on the LOGO display until *Air inlet* is selected.
- 2) AC: Adjust the air supply pressure regulator under AC until flowmeter, FI-11, under AC is 1.0 l/min.

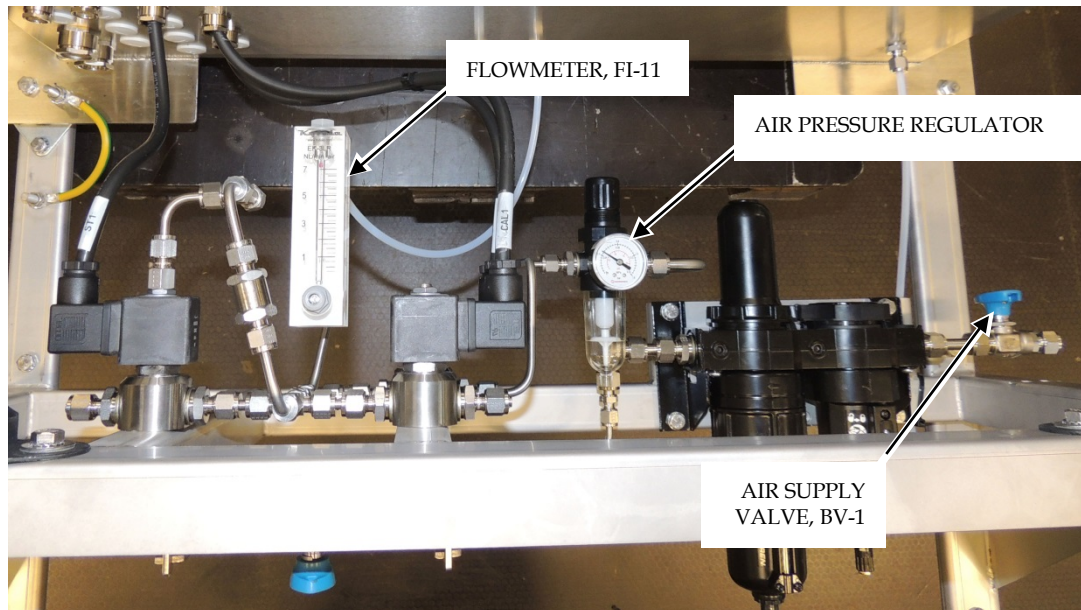

- 3) AC: Press F4 button until Span inlet is selected.
- 4) Make sure the gas regulator (refer to figure below) is fully closed. (Fully turned counterclockwise.)

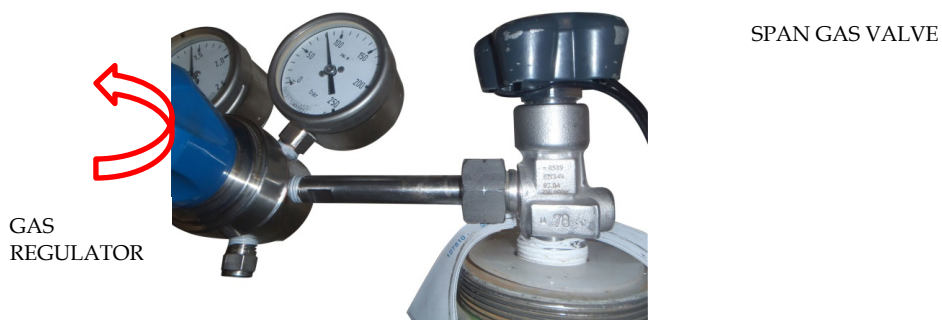

- 5) Open span gas valve on the cylinder and carefully open gas regulator (several turns clockwise) until flowmeter, FI-11, under AC (refer to figure above) shows 1.0 l/min.
- 6) Flow settings are completed.

### 5.3.3 Changing calibration interval on the analyser module

At delivery automatic start of calibration is switched off. It is easily activated, but Norsk Analyse recommends manual calibration. If necessary, contact Norsk Analyse for further guidance on how to activate this function.

---

*Note*      *If automatic start of calibration cycle is activated, it is very important that calibration gas bottle always is open. The system should be checked at least once a week to make sure all pressures are OK and that there is no leakage from calibration gas cylinder.*

---

### 5.3.4 Changing measuring range on the analyser module

---

*Note*      *If range is changed from default setting it will require optional SC-IU to be programmed accordingly as well. Always consult Norsk Analyse before making any changes to the measuring range.*

---

ShipCEMS is delivered with a default measuring range for conversion of the gas components measured (in ppm or vol%) to 4-20mA signals that are transmitted by either analog or fieldbus communication to scrubber automation system.

Note that when setting a higher range, the accuracy of the readings will be lower, and vice versa.

- 1) Enter function code 40 for SO<sub>2</sub> or CO<sub>2</sub> on the analyser module to change the range selection to correct measuring range.

If correct measuring range is not listed (MR1 - MR4) go to the next step.

- 2) Enter function code 41 to define measuring range (MR1 - MR4) for SO<sub>2</sub> or CO<sub>2</sub>.
- 3) Enter the correct measuring range.

SO<sub>2</sub>: Either 0-50 vpm or 0-200 vpm (same range for MR1 - MR4)

CO<sub>2</sub>: 0 to 10% or 0 to 15% (same range for MR1 - MR4)



### 5.3.5 Changing temperature controller settings

The temperature controller is used to control both the heater relay (#1) and the gas pump relay (#2). It is mounted inside the SCS junction box (left of the moisture sensor).

The default relay temperature settings are as follows:

- Heater relay
  - Temperature set point SP1=60.0°C
  - Hysteresis HYS1=1.0°C
- Gas pump relay
  - Temperature set point SP2=55.0°C
  - Hysteresis HYS2=1.0°C

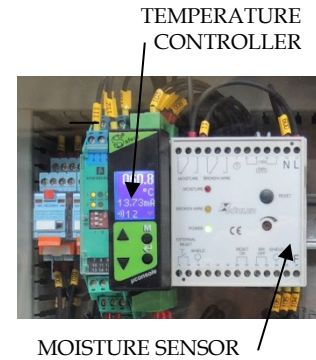

The temperature controller settings are programmed from Norsk Analyse and are normally not changed.

### 5.3.6 Changing fieldbus address in optional interface unit (SC-IU)

For connection, refer to *Installation manual chapter 7.4.3* or the following document:

→ *NA-E-SPC-068 Fieldbus Connection (AC)*.

## 5.4 Controlled Shutdown

**Caution**     *Make sure Back-purge is running when scrubber is turned off!*

When the scrubber is not running for a period, it is very important that back-purge is activated. For systems with SC-IU back-purge is automatically turned on, but for analog system back-purge is activated manually.

If the ShipCEMS system is not used for a longer period back-purge must still run, but other parts of the sample conditioning cabinet and the whole analyser cabinet can be turned off.

### Shut down part of sample conditioning cabinet:

- 1) Turn off pump by using MS-1.  
Back-purge must run to protect the system.

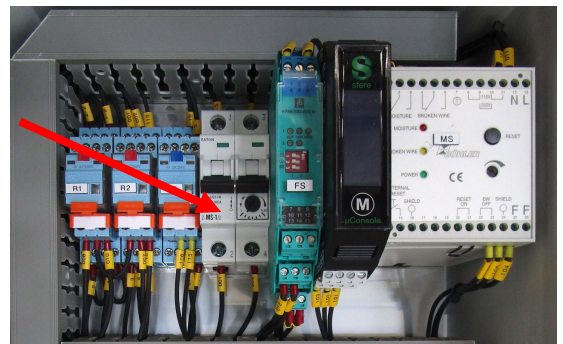

### Shut down analyser cabinet:

- 1) Turn off cabinet by using main switch.

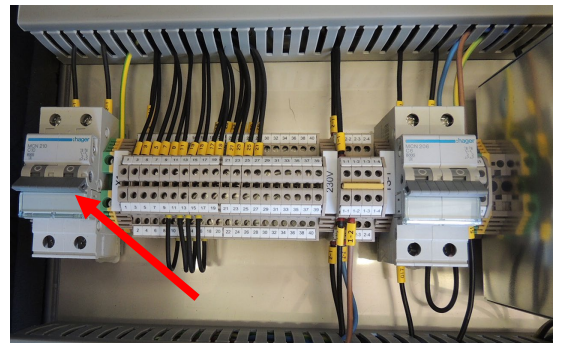

### 5.4.1 Start-up after controlled Shutdown

Start the analyser by the main switch in the analyser cabinet and the MS-1 in the sample conditioning cabinet. The system will resume the old settings.

The time from start-up to ready system is approx. 45 minutes.

### 5.4.2 Maintenance

Since back-purge is running, perform maintenance on air filter unit, particle filter and oil absorbing filter according to regular maintenance schedule.

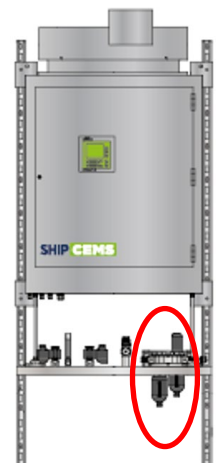

## 5.5 Change IP address in WAGO PLC (AC)

The PC and the PLC must be located within the same subnet. The instruction below shows how to change the IP address in SI-IU/WAGO PLC (AC).

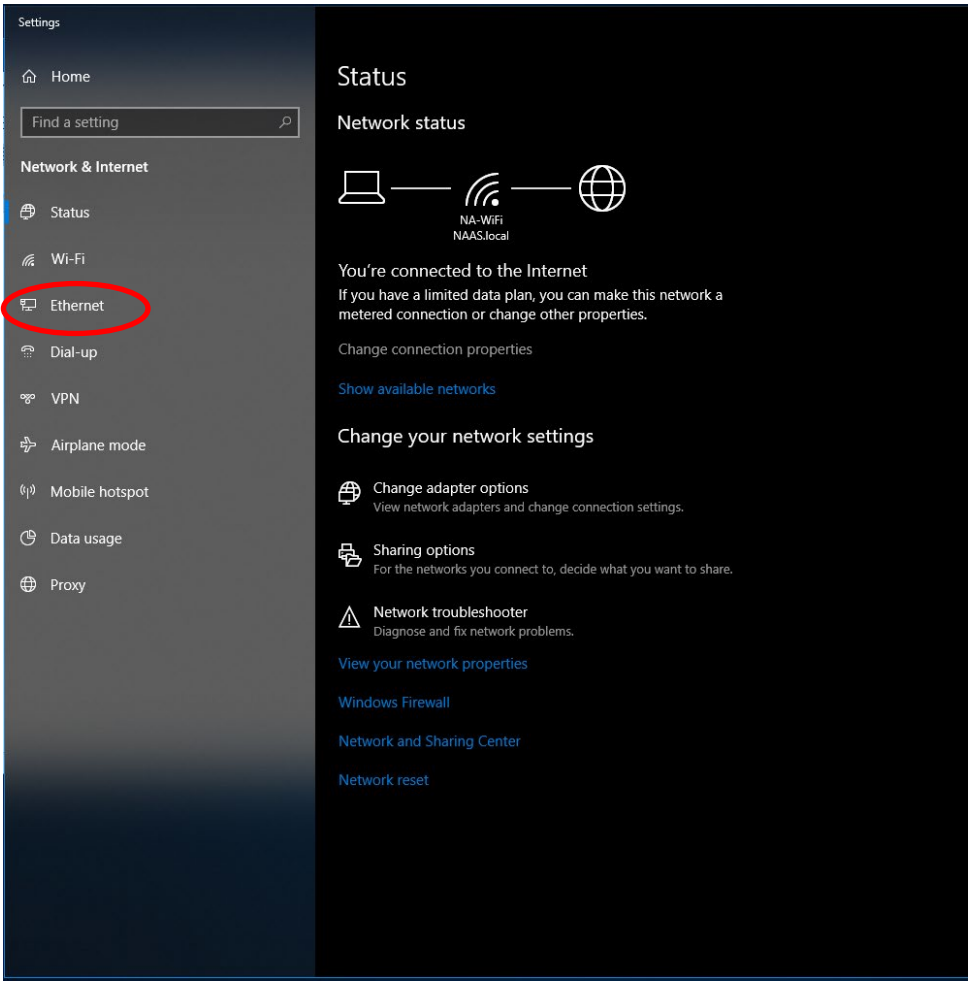
Step	Description	Sign
1	<p>Find the fixed IP address on the computer.</p> <p>Go to Settings&gt;Network &amp; Internet.</p> <p>Select <i>Ethernet</i>.</p> 	

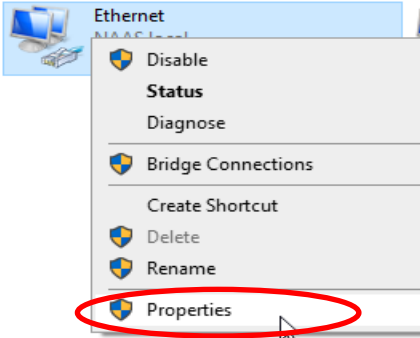
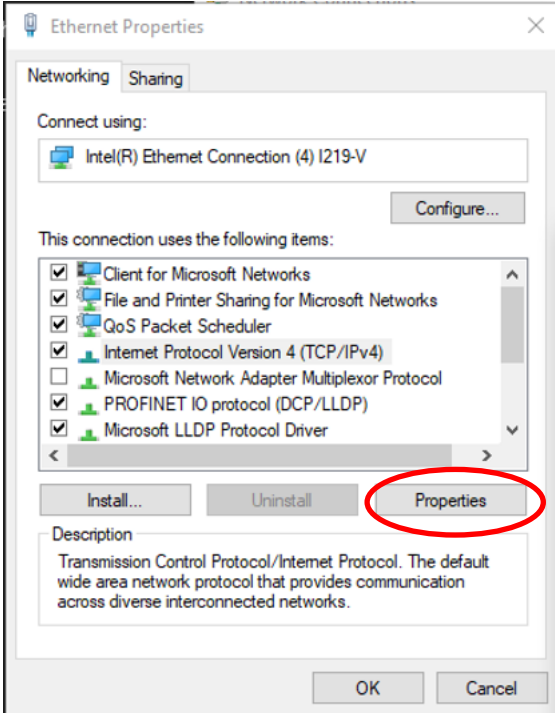
Step	Description	Sign
2	<p>Select <i>Change adapter options</i>.</p> 	
3	<p>Right click on Ethernet and select <i>Properties</i>.</p> 	
4	<p>Select <i>Properties</i> and OK.</p> 	

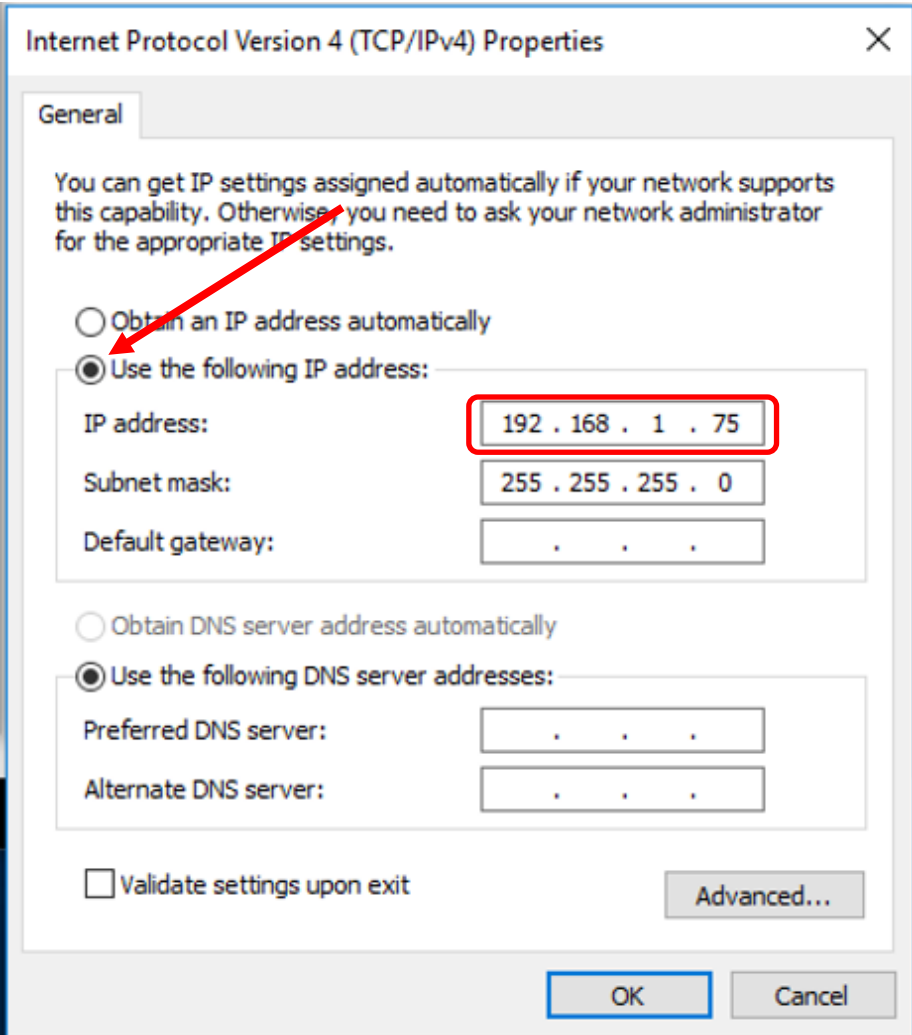
Step	Description	Sign
5	<p>a) Select <i>Use the following IP address</i>.</p> <p>b) The marked filed is empty. Enter <b>192.168.1.75</b>.</p> <p>c) Make sure that the subnet mask is 255.255.255.0.</p> <p>d) Click OK.</p> 	

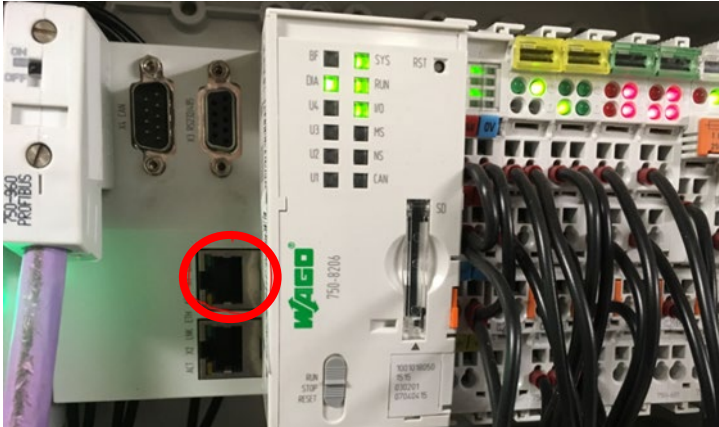
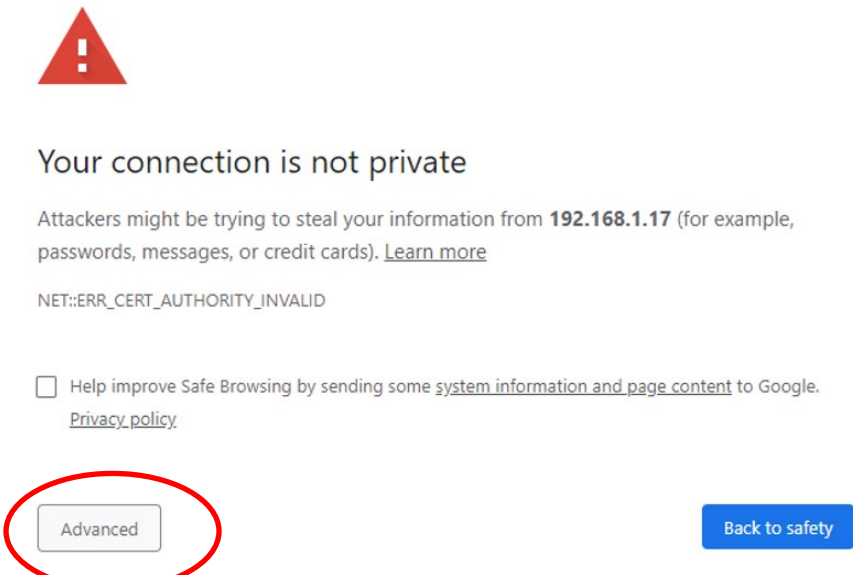
Step	Description	Sign
6	<p>Connect the ethernet cable from the laptop to port 1.</p> 	
7	<p>Open Firefox or Chrome browser. Enter "https://192.168.1.17/wbm/". Agree to continue even though the computer recommends you not to.</p> <hr/> <p><i>Note</i>            <i>It will most likely not work using Internet Explorer.</i></p> <p><i>Note</i>            <i>Disconnect client cable, if connected, to avoid potential IP-conflict on network.</i></p>	
8	<p>Select <i>Advanced</i>.</p> 	

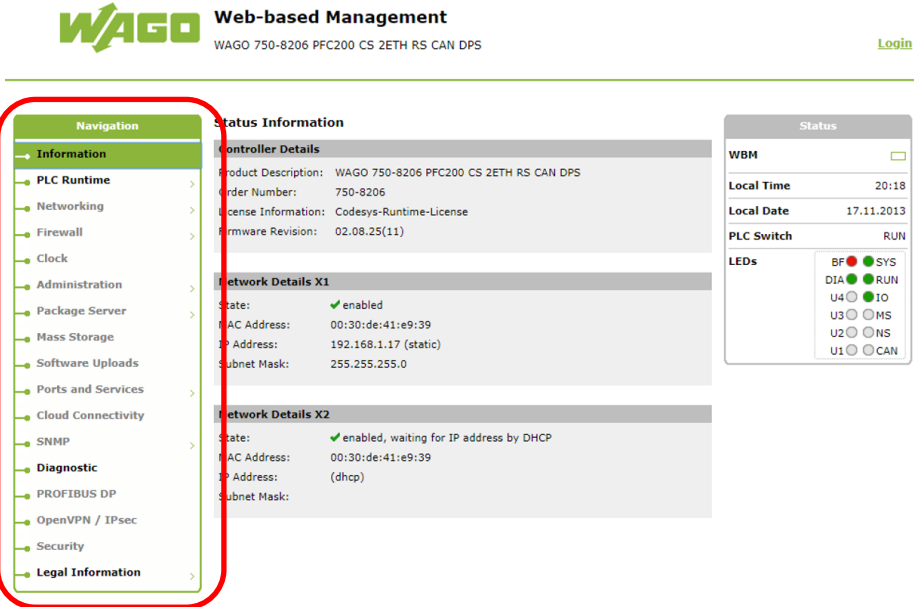
Step	Description	Sign
9	<p>Select <i>Proceed to 192.168.1.17 (unsafe)</i>.</p>  <p><b>Your connection is not private</b></p> <p>Attackers might be trying to steal your information from <b>192.168.1.17</b> (for example, passwords, messages, or credit cards). <a href="#">Learn more</a></p> <p>NET::ERR_CERT_AUTHORITY_INVALID</p> <p><input type="checkbox"/> Help improve Safe Browsing by sending some <a href="#">system information and page content</a> to Google. <a href="#">Privacy policy</a></p> <p><input type="button" value="Hide advanced"/> <input type="button" value="Back to safety"/></p> <p>This server could not prove that it is <b>192.168.1.17</b>; its security certificate is not trusted by your computer's operating system. This may be caused by a misconfiguration or an attacker intercepting your connection.</p> <p><a href="#">Proceed to 192.168.1.17 (unsafe)</a></p>	
10	<p>Wago web page opens up. Click anywhere in the marked field to get to the login.</p> 	

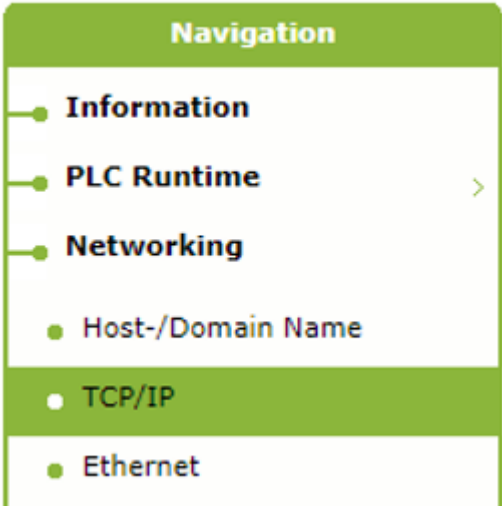
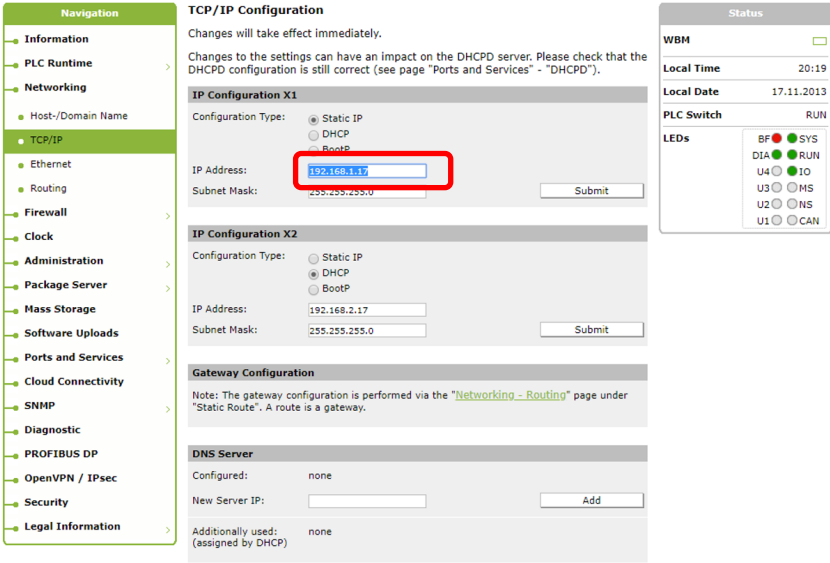
Step	Description	Sign
11	Login: Admin Password: wago	
12	Select <i>Navigation</i> and then <i>TCP/IP</i> . 	
13	The marked field has the following IP address: <i>192.168.1.17</i> 	
14	Enter the new IP address: <hr/>	

Step	Description	Sign
15	<p>Select <i>Submit</i>. (You will be logged out).</p>	
16	<p>Login with new IP address to verify successful IP address change:</p> <hr/> <p>Open Firefox or Chrome browser. Enter "https://xxx.xxx.xxx.xxx/wbm/".</p>	

# 6 Troubleshooting

## 6.1 Troubleshooting philosophy

ShipCEMS can recognise system irregularities and will send messages accordingly. These messages can be sorted in two categories:

- Alarms
- Information messages

---

*Caution*      *Alarms must be attended to immediately, as these indicate system faults that may be harmful to the equipment.*

---

Information messages need not influence the measuring ability of the analyser at the time they occur. It is however recommended to carry out remedial measures in order to guarantee reliable measurements.

All alarms and information messages are displayed on the screen of the LOGO display unit. Note that several messages may be present at a given time. The fault message of the highest priority order is then displayed on top. The LOGO UP/DOWN buttons must then be used to navigate to other messages present.

All messages will also be sent as a common digital alarm signal to the Scrubber Automation System.

Individual error messages, possible causes and actions to be taken are described in tables in chapter 6.2.2, 6.3 and 6.4.

## 6.2 Signals

### 6.2.1 Output signals on standard ShipCEMS

Description	Type
AC ALARM	Digital alarm
SCS ALARM (COMMON)	Digital alarm
MAINTENANCE IN PROGRESS	Digital information message
MEASUREMENT VALID	Digital information message
CO <sub>2</sub> VALUE	Analogue 4 - 20 mA
SO <sub>2</sub> VALUE	Analogue 4 - 20 mA

### 6.2.2 Status signals on Interface unit (SC-IU) using fieldbus

Optional. Refer to the following document:

→ *NA-E-SPC-068 ShipCEMS Fieldbus Specification*

Description	Type	Meaning
AC Alarm	Alarm signal	1= System OK
SCS Alarm	Alarm Signal	1 = System OK
Maintenance in progress	Information signal	1 = Maintenance on system
Measurement valid	Information signal	1 = Measurement is currently valid
CO <sub>2</sub> _RAW	Measured value	Actual measured value from system
SO <sub>2</sub> _RAW	Measured value	Actual measured value from system
CO <sub>2</sub> _Stream1..4	Measured value	Actual measured value from system
SO <sub>2</sub> _Stream1..4	Measured value	Actual measured value from system

---

*Note*      *IF SC\_IU is installed: Fieldbus variables "Gas component" \_RAW values are always updated according to analyser readings. "Gas component" \_STREAM1..4 values only updates for corresponding stream and when measurement is valid.*

---

## 6.3 Alarms, LOGO unit

Refer to Figure 6 for location of LOGO unit inside the AC.

Display message	Possible cause	Action
FUNCTION CONTROL U6	Alarm message from analyser module (resulting from internal function control).  Normally displayed when in warm-up mode or when analyser settings have been changed.	Check message on analyser display.  Press the MEAS button to return to measurement mode.  Contact Norsk Analyse for more information.
LOW FLOW U6	Alarm message from analyser module.  There is no sample flow to the analyser.  Note that a low flow alarm is activated when the scrubber is shut down and the system is automatically set to idle mode.	Check analyser's integrated flow meter.  Perform visual check to locate the fault.  If T-union is clogged rinse or replace T-union. Refer to chapter 7.3.7.
MAINTENANCE REQUEST U6	Maintenance request from analyser module.  Possible fault with automatic calibration or other internal analyser processes.	Check request message on analyser display.  Check filters in case these are contaminated.  Refer to read log in section 6.7.1.1. Record analyser's error log and contact Norsk Analyse for further actions.
SCS ALARM #1 (#2, #3 and #4)	General alarm from sample conditioning system(s).  Fault with sample conditioning system no. 1 to 4 respectively.  This alarm will occur when SCS or probe is not heated to set point.	Access the relevant SCS cabinet (up to four cabinets for multi-funnel applications).  Perform visual check, functional test and alarm test as required to locate the fault.

## 6.4 Information messages, LOGO unit

Refer to Figure 6 for location of LOGO unit inside the AC.

Display message	Possible cause
AIR INLET OPEN	Manual opening of solenoid valve for instrument air (function F4)
AUTO CALIBRATING	Calibration mode is entered (function F3)
CALIBRATION IN PROGRESS U6	Automatic calibration of analyser module is performed
MAINTENANCE MODE	Maintenance mode is entered (function F1)
MEASURING STREAM #1, #2, #3 and #4	Normal operation
SAMPLE #1, #2, #3 and #4 VALID	Normal operation
IDLE MODE	No stream is selected for measurement.
SERVICE MODE	Service mode is entered (function F4)
SPAN CHECK	Span check of analyser module is performed (function F2)
SPAN INLET OPEN	Manual opening of solenoid valve for calibration gas (function F4)
STREAM #1, #2, #3 and #4) OPEN	Manual opening of solenoid valve for sample from SCS (function F4)

## 6.5 Moisture alarms

The red moisture alarm indicator can be turned on during the process but is turned off once the sample is completely dry.

During moisture alarm the sample outlet valve is closed and the sample goes in a loop until the sample is dry.

If the alarm remains, perform the measures listed in the table below. If the alarm persists, contact Norsk Analyse.

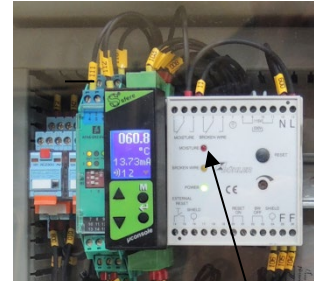

MOISTURE SENSOR  
ALARM INDICATOR

Display message	Possible cause	Action
Alarm indicator is lit up. Refer to figure above.	Visually check if there is water in the bottom of the sample gas filter element.  Refer to 0 for pictures.	Refer to 0 to remove the glass cup and empty the water. Replace the glass cup.  Check if the alarm is turned off after approx. 5 minutes.
Alarm indicator is lit up. Refer to figure above.	Dryer tubes could be worn and need replacement.	Refer to 7.3.9 to replace the dryer tubes.  Contact Norsk Analyse for support.

### 6.5.1 Adjust sensitivity of moisture sensor

**Caution** *To prevent risk of damage to equipment and/or malfunction of system, it is absolutely crucial that the sensitivity of the moisture sensor is adjusted during start-up.*

It is crucial to ensure proper functionality and to prevent possible damage to the ShipCEMS system that moisture sensor sensitivity is set to a proper level. This must be done at actual installation during commissioning to ensure sensitivity matches dew point of available instrument air.

Prior to adjustment, the system should be fully functional and operational. Make absolutely sure there are no traces of moisture anywhere in the system. Check tubing and filter housing thoroughly.

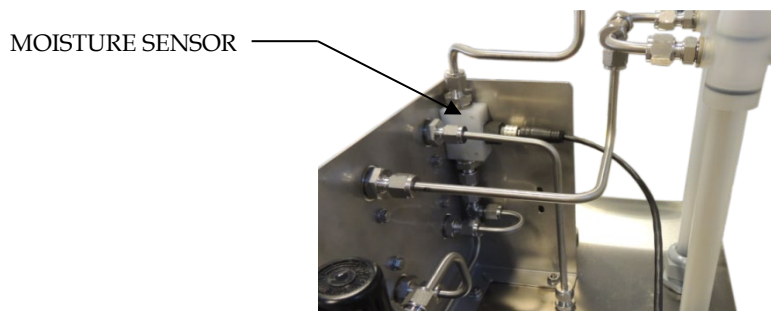

Figure 11 *Moisture sensor*

- 1) When scrubber is running and system is sampling, disconnect the heated sample line in SCS to make sure the sample is ambient air. Refer to Figure 12. Refer to Figure 1 for overview of installations.

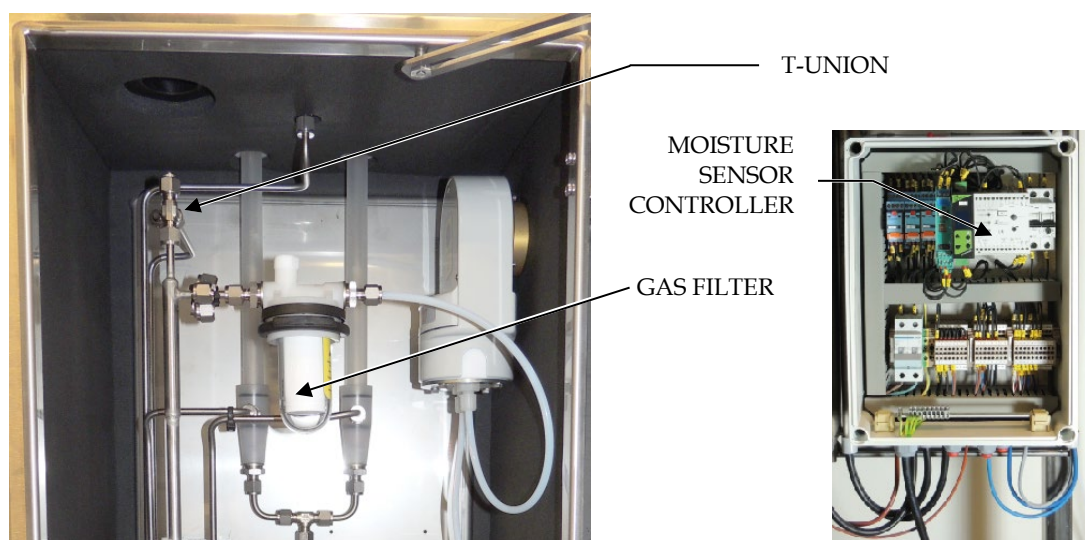

Figure 12 *Disconnect heated sample line to make the system analyse ambient air*

- 2) Locate moisture sensor controller. Refer to Figure 12.

- 3) Make sure bridge for "RESET ON" is removed. Refer to Figure 13.
- 4) Adjust potentiometer clockwise until moisture alarm is activated (red LED). Refer to Figure 13.
- 5) To adjust the moisture sensor against ambient air, reset the alarm and activate the set point by adjusting the potentiometer  $\frac{1}{4}$  turn counter clockwise. Refer to Figure 13. (The red LED is turned off.)

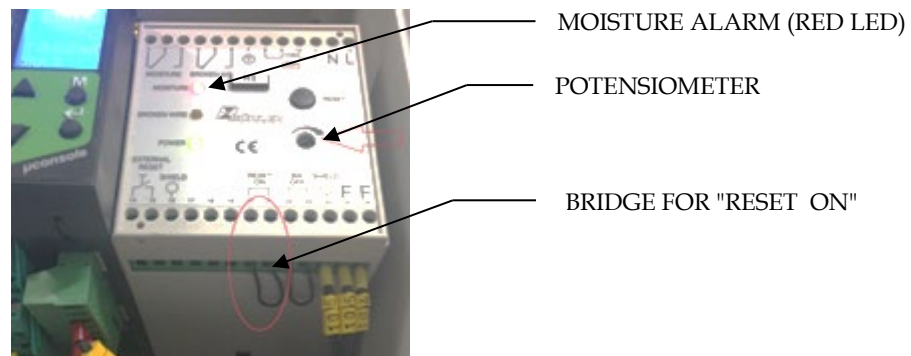

Figure 13 Moisture sensor controller

- 6) Re-connect heated sample line in SCS. Refer to Figure 12.
- 7) The sample conditioning cabinet is grounded by attachment on wall and junction box is grounded by the main power inlet. There is an extra earth stud (M8 x 30) under the cabinet if additional grounding of sample conditional cabinet is necessary.



## 6.6 General troubleshooting procedure

Troubleshooting may be complex and requires good knowledge of ShipCEMS. Onboard service personnel should therefore compile and update troubleshooting guidelines over time while gathering system experience.

The following procedure therefore indicates some check points that could be included in a troubleshooting routine when an alarm has been received.

If necessary, contact Norsk Analyse for further advice or for service request.

## 6.7 Troubleshooting procedures

### 6.7.1 Analyser fault

#### 6.7.1.1 Read log

- 1) Press function code 3 on the analyser module to read the log.
- 2) Select the channel to check the log for either SO<sub>2</sub> or CO<sub>2</sub>.
- 3) Enter code 111 and press enter.  
(The digits (111) are not visible on the screen.)
- 4) Scroll through the log pages to read the entire log and errors that have occurred.
- 5) Press ESC to exit.

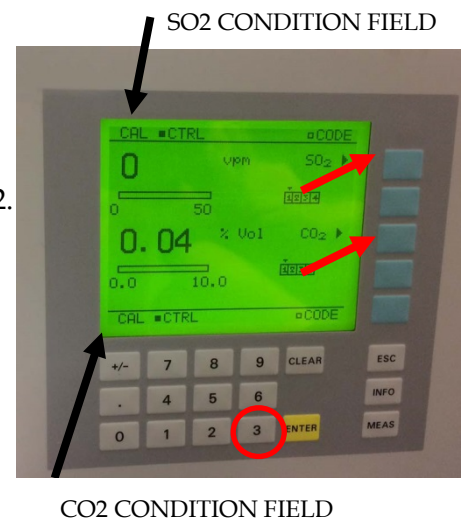

### 6.7.1.2 Delete log

For some specific alarms the analogue output will freeze and the analyser system stop working. To get operational again the log must be deleted.

---

**Caution**      *Save all log pages! Use camera or write it down!  
This is very important for support purposes.*

---

- 1) Take a picture of all the log pages.
- 2) Press function code 60 on the analyser unit.
- 3) Select the channel to delete, either SO<sub>2</sub> or CO<sub>2</sub>.
- 4) For CO<sub>2</sub>: Enter code 111 and press enter (for SO<sub>2</sub> no code is needed).  
(The digits (111) are not visible on the screen.)
- 5) Press “clear logbook”

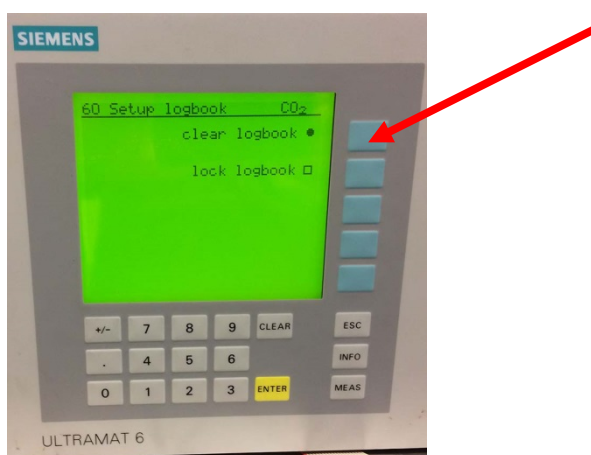

- 6) Press “MEAS” button once, wait 3 seconds and press “MEAS” button again.
- 7) Log is now deleted.

### 6.7.2 Visual check, analyser system

- 1) Check that the atmospheric vent is connected and that it is not restricted.
- 2) Check electrical wiring. Inspect the internal terminals for loose wires.
- 3) Check for correct mounting of the analyser module inside its vibration rack.
- 4) Verify that all equipment is connected to its correct fuse.
- 5) Verify correct current rating for all fuses.
- 6) Check for loose fittings. Check tightness by hand.
- 7) Check the vibration mounting for non-tightened bolts.

### 6.7.3 Visual check, SCS

- 1) Check electrical wiring. Inspect the junction box terminals for loose wires.
- 2) Verify that all equipment is connected to its correct fuse.
- 3) Verify correct current rating for all fuses.
- 4) Check filter quality by inspecting the filter housing and filter element.
- 5) Check for loose fittings. Check tightness by hand.
- 6) Inspect the gas pump for any damage or for obstacles.

### 6.7.4 Functional test, SCS

- 1) Apply 230 VAC power to the cabinet.
- 2) Verify that the gas pump starts by manually activating relay R2.
- 3) Verify that the heater starts heating (up to maximum 60°C).
- 4) Close the cabinet door. This will test that the pump auto starts (at 55°C).
- 5) Verify that the heater stops heating when cabinet temperature reaches 60°C. Inspect at relay R1.

### 6.7.5 Alarm test, SCS

- 1) Moisture alarm: Generate a moisture alarm and verify that the sample shut off solenoid valve closes and that the flow to the analyser system drops. The flow in recycle loop should increase. No alarm is sent to the analyser system.
- 2) Temperature alarm: Open the cabinet door and verify that pump stops when the temperature drops below 55°C. An alarm shall be sent to the analyser system and the error be reported in LOGO display.
- 3) Probe sample temperature alarm: Cut power supply to the probe and let the probe temperature drop below operating temperature. Verify that the gas pump stops. An alarm shall be sent to the analyser system and the error be reported in LOGO display.
- 4) Dryer air flow alarm: Block for purge air. Verify that the gas pump stops. An alarm shall be sent to the analyser system and the error be reported in LOGO display.

# 7 Maintenance

## 7.1 Maintenance philosophy

The maintenance philosophy recommended by Norsk Analyse is:

- Maintenance should be carried out by skilled personnel. The maintenance should include the following:
  - Calibrations and validations
  - Functional tests
- Replacement of faulty parts should be limited to the replaceable units recommended in the spare part list.

Whenever a faulty unit has been replaced, the unserviceable unit should be sent to Norsk Analyse, or an appointed dealer, for repair.

---

*Note*                      *Always follow the recommended maintenance of the different units. System performance and reliability may decline if these recommendations are not followed and may also render the guarantee void.*

---

## 7.2 Maintenance schedule

Maintenance routines must be performed regularly as stated in the following tables to ensure optimal performance and a long operational life of the system and its components.

The preventive maintenance program shall by defined time intervals guide the ShipCEMS technician through an inspection, repair and replacement program. This will enable ShipCEMS to be operational, to reduce the number of expected alarms, to eliminate the number of unexpected alarms and to measure correctly.

The proposed maintenance schedule must be accommodated to authoritative legislation and actual operational conditions. The customer should thus work out a local maintenance plan.

---

*Note*                      *The maintenance schedule indicates the maximum recommended intervals between which the various routines should be performed.*

---

### 7.2.1 Daily routine

Unit	Remarks
Heated sample line	Check temperature by hand. Sample tube should be noticeably warm at probe outlet and cabinet inlet.
All instruments	Check instrument displays for fault messages.
Filters	Check filters in SCS and probe.
Air dryer (optional)	<ul style="list-style-type: none"> <li>• Check and clean dryer. If red service light appears, request a dryer service kit (refer to chapter 7.3.17)</li> <li>• Check dew point sensor display (if installed). If the dewpoint is not maintained at <math>&lt;-30^{\circ}\text{C}</math> the reading on the display will alternate with "dewpoint alarm" every 5 seconds. The no-volt alarm will also activate.</li> </ul>

### 7.2.2 Weekly routine

Unit	Remarks
Cooler unit	Check that air inlet and outlet vents are free from sand, dust or other foreign matters.
Analyser module	<p>Check flow on span and air inlets by using the flowmeter mounted on lower support bracket of analyser cabinet. (LOGO Function F4). Normal flow is 1 to 1.0 l/min. Alarm if flow <math>&lt; 0.8</math> l/min.</p> <hr/> <p><i>Note</i>                      <i>Adjust flow using regulators</i>    <i>- not the flowmeter!</i></p> <hr/> <p>Refer to <i>Flow adjustment</i> in chapter 5.3.1. Use span check (LOGO function F2). Carry out calibration procedure (LOGO function F3) if readings differ from value on calibration gas bottle carry out. Intervals for span check may be extended if deviations are insignificant.</p>
SCS	Check for liquid in the liquid collection tube. Empty.
Air conditioner unit in analyser cabinet	Check both internal and external fans. Replace fans if they are not working. Air cooler Part no: [116603] Internal fan Part no: [134971] External fan Part no: TBA.

### 7.2.3 Bi-weekly routine

Unit	Remarks
Calibration	<p>Perform bi-weekly span check (LOGO function F2).</p> <p>If deviation is significant perform a calibration (LOGO function F3).</p> <p>Norsk Analyse recommends calibration every two weeks to make sure the analyser is accurate at all time. Intervals may be extended if the deviation is insignificant.</p>

### 7.2.4 Monthly routine

Unit	Remarks
Cabinet and unit exterior	Clean all surfaces.
Calibration	<p><b>MANDATORY MONTHLY!</b> (but bi-weekly is recommended by Norsk Analyse)</p> <p>To be in compliance with the type approval certificate issued for this analyser, manual calibration must be performed every 30 days.</p> <p>Perform calibration (LOGO function F3).</p> <p>Check expiration date on cylinder. Order new cylinder if pressure drops below 50 barg.</p>
Sample line inside cabinet	Check all tubing visually for condensation, contamination and leaks.
Sample probe filter	<p>Check for contamination and physical damage. Replace filter element if required.</p> <p>Part no: 122247.</p>
Sample gas filter	<p>Visual check for contamination and physical damage. Replace as required.</p> <p>May be replaced earlier if flow is reduced to such a level that alarms are active or if filter is contaminated.</p> <p>Part no: 133615.</p>
Particle filter in Air Filter Unit	<p>Check filter for contamination. Replace if required.</p> <p>Part no: 122233.</p>
Oil absorbing filter in Air Filter Unit	<p>Check filter for contamination. Replace if required.</p> <p>Part no: 122234.</p>

### 7.2.5 Routine every six months

Unit	Remarks
Sample probe filter	Replace filter element. Part no: 122247.
Sample gas filter	Replace filter element. May be replaced earlier if flow is reduced to such a level that alarms are active or if filter is contaminated. Part no: 133615.
Calibration gas cylinder	Check expiration date on cylinder. Order new cylinder if pressure drops below 50 barg
Drip tray drain	Clean the drip tray drain. Refer to 7.3.5.

### 7.2.6 Yearly routine

Unit	Remarks
Cabinet and units	Check bolts. Tighten if necessary
Heated sample line	Check for moisture and contaminations. Clean as required. Refer to 7.3.14.
Gas pump membrane	Check physical condition. Replace if required (*). Part no: 122244.
Solenoid valves	Perform functional test. Refer to 6.7.4. Perform leak test. Refer to 7.3.15.
Particle filter in air filter unit	Replace filter. Part no: 122233.
Oil absorbing filter in air filter unit	Replace filter. Part no: 122234.
Sample probe with demister	Replace filling on demister. Part no: 129961
Analyser condense trap	Replace condense trap. Refer to chapter 7.3.12. Part no: 128732
Air conditioner unit in analyser cabinet	Clean the heatsinks with compressed air.

Note (\*) - Membrane replacement shall be performed by personnel from Norsk Analyse, unless agreed otherwise between customer and Norsk Analyse.

### 7.2.7 Routine every two years

Unit	Remarks
Air dryer	Perform service every two years or 12000 hrs. Part no: 129792 (1-2 streams) Part no: 129794 (3-4 streams)

### 7.2.8 Routine every three years

Unit	Remarks
Gas pump maintenance kit	Replace spare parts. Part no: 122242
Calibration gas cylinder	Replace cylinder. Order from Norsk Analyse. Part no: 135030 Part no: 125621 Part no: 135142
Dryer tubes (sample gas dryer)	Replace dryer tubes. Refer to chapter 7.3.9. Part no: 122235

### 7.2.9 Routine every four years

Unit	Remarks
Air dryer	Perform service every four years or 24000 hrs. Part no: 134827 (1-2 streams) Part no: 134831 (3-4 streams)

## 7.3 Maintenance procedures

### 7.3.1 Replacing or dismantling of internal parts in the analyser module

The analyser module is a sensitive device. Replacing or dismantling serviceable parts inside the unit can only be performed by service personnel authorised by Norsk Analyse.

---

*Caution*     *If this is not followed, the warranty will no longer be valid.*

---

### 7.3.2 Cleaning cabinet exterior and surfaces

- 1) Clean the exterior of cabinets and other surfaces with a sponge or cloth soaked in water contained cleansing agent.
- 2) Wipe down all surfaces afterward with a clean, damp cloth to remove the detergent.

---

*Note*     *The surface of screen display areas must only be cleaned using a slight pressure to prevent damage to the thin foil.*

*Note*     *Make sure that water does not enter the analyser or other units when cleaning.*

---

- 3) If necessary, dust may be removed from the interior of cabinets by carefully using a compressed air gun.

### 7.3.3 Replacing sample probe filter element

**Part no: 122247**

The sample probe contains a filter element made of an inert ceramic material. The filter element is passive and does not add or absorb any of the trace components to be measured. It is not necessary to shut off power during filter replacement.

- 1) Open the protective shield to access the sample probe.
- 2) Turn the probe handle 90 degrees counterclockwise and pull the handle with the filter straight out.

---

**Warning**      *Avoid touching hot parts of the sample probe, including the filter element.*

---

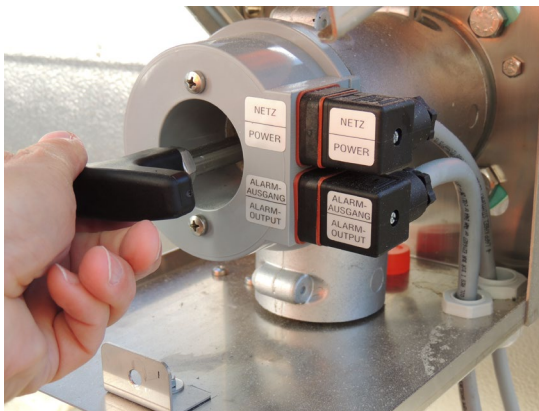

- 3) Replace filter according to steps below:
  - a) Replace filter if it is discoloured right through.
  - b) Lubricate and change O-rings.
  - c) Lubricate the internal O-ring on the filter with lubrication delivered with the filter.

---

**Caution**      *Do not drop the filter to ground, as the unit is sensitive to shock loads.*

---

- 4) Reinsert the handle with the cleaned or replaced filter and turn the handle 90 degrees clockwise to fasten.

### 7.3.4 Replacing sample gas filter element II-type

Refer to general arrangement drawings [1801].

**Part no: 133615**

The SCS cabinet contains a filter element. The filter element is passive and does not add or absorb any of the trace components to be measured.

If a moisture alarm has been activated, the filter must always be attended to.

- 1) Open the cabinet to access the filter.
- 2) Visually check for moisture or contamination in the glass container and surrounding tubing.
- 3) Wait until the pump has stopped to avoid pressure in plastic cup.
- 4) Open the filter housing by pulling out the plastic locking ring.
- 5) Pull the glass cup holding the filter straight down. It is only pushed up onto the element holder.

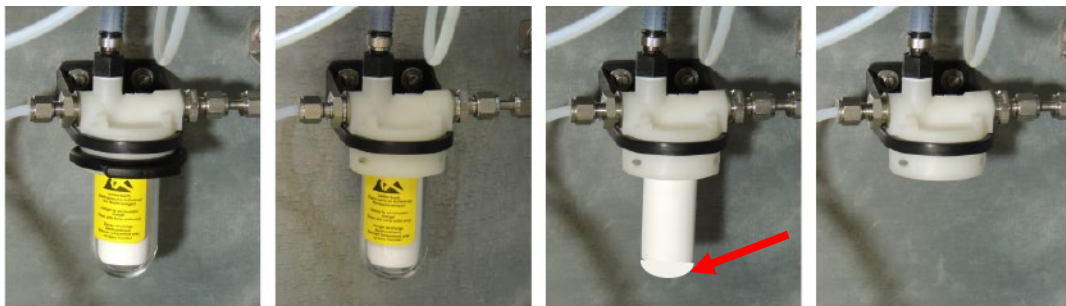
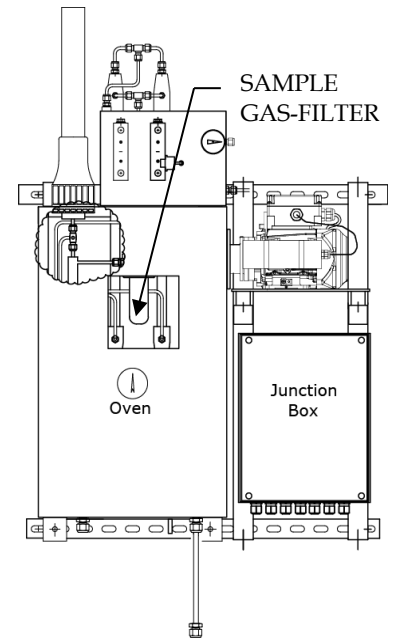

- 6) Unscrew the spacer pin (red arrow) and replace the filter element.
- 7) Make sure that the top of the filter element seals in the top
- 8) Reassemble the sample gas filter unit.

It is not necessary to shut off power during filter replacement. The SCS will reheat, and then the pump will restart when the cabinet temperature reaches +55°C.

### 7.3.5 Cleaning the drip tray drain

In analyser cabinet, AC:

*Note Always keep the cabinet doors of the closed to prevent dust and dirt from entering.*

#### 7.3.5.1 Preventive measures

*Caution Make sure water is not collected on drip tray! The procedure below might splash water over analyser and other sensitive equipment. If there is water on the drip tray refer to the following chapter.*

Use instrument air and blow the drain hose clean. Put the compressed air gun in the end of the drain hose and rinse hose. Refer to figure.

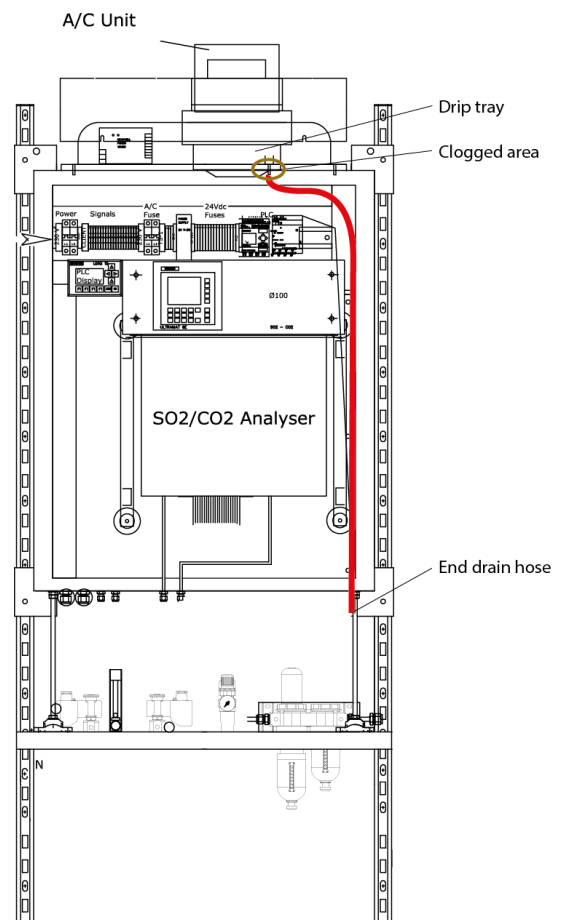

### 7.3.5.2 Cleaning the drip tray drain if water is collected on tray

- 1) Turn off power for the analyser cabinet.

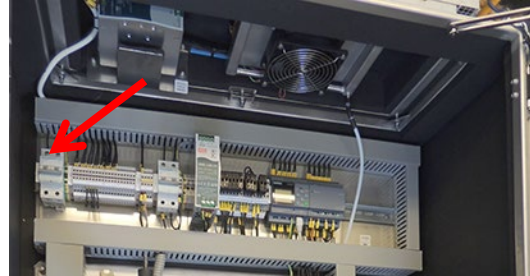

- 2) Disconnect hose from drip tray.

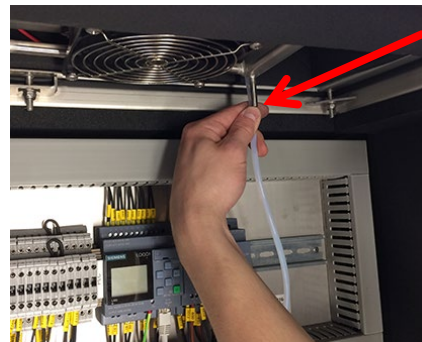

- 3) Clean drip tray drain using e.g. a screw driver.

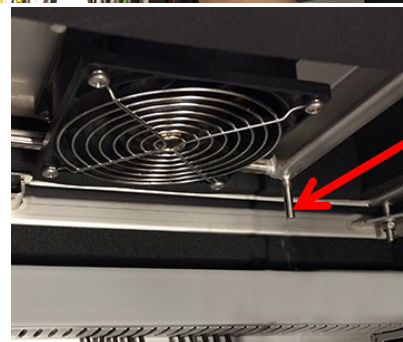

- 4) Point the disconnected hose away from cabinet and use compressed air to rinse the drain hose.

---

**Caution**    *Make sure water is not splashing inside the cabinet.*

---

- 5) Attach hose to drip tray drain. Refer to step 2.
- 6) Turn on power. Refer to step 1.

### 7.3.6 Install or replace the calibration gas cylinder

Part no: **135030:** 160 ppm SO<sub>2</sub>, 8 mol% CO<sub>2</sub>, Rest N<sub>2</sub>  
**125621:** 40 ppm SO<sub>2</sub>, 8 mol% CO<sub>2</sub>, Rest N<sub>2</sub>  
**135142:** 160 ppm SO<sub>2</sub>, 12 mol% CO<sub>2</sub>, Rest N<sub>2</sub>

When the calibration gas cylinder is replaced, it is necessary to perform a recalibration of the analyser module afterwards.

- 1) Ensure that the solenoid valve controlling flow from the gas cylinder is closed. When the system is in normal operational mode, this valve will be closed. If not, use the LOGO to close the valve.
- 2) Ensure that the gas cylinder's outlet valve is firmly shut.
- 3) Unscrew the regulator fittings.
- 4) Remove all mechanical fasteners.

**Caution**      *Never allow gas cylinders to fall.*

**Caution**      *Keep caps on while moving gas cylinders.*

- 5) Replace the gas cylinder and ensure that the new cylinder is properly fastened.

Use function number 22 on the analyser module to adjust correct set points for span and gas calibration. Refer to manufacturer's documentation for menu guidance. Pass code for analyser module (level 1): 111

**Enter calibration cylinder values into the analyser:**

**For SO<sub>2</sub>:**

Insert Zero set point 0.00 vpm.

Insert MR1-MR4 set point according to values for SO<sub>2</sub> concentration found on the cylinder.

SO<sub>2</sub>: .....

**For CO<sub>2</sub>:**

Enter function code 22. Insert Zero set point 0.04 vpm.

Insert MR1-MR4 set point according to values for CO<sub>2</sub> concentration found on the cylinder.

CO<sub>2</sub>: .....

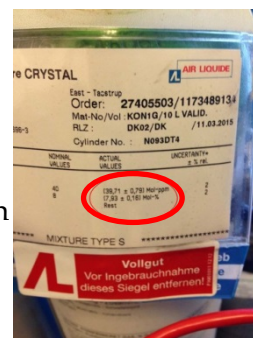

Adjust the regulator on the new gas cylinder for correct flow to the analyser system.

- a) Press F4 on the LOGO to open span inlet (in order to adjust regulator on gas cylinder).
- b) Perform flow adjustment according to chapter 5.3.1.
- c) Use the LOGO to enter Calibration mode (F3 button). Activate the necessary solenoid valves to allow instrument air and calibration gas to flow through the system.

### 7.3.7 Emptying the liquid collection tube

- 1) Check if liquid is collected in the tube.
- 2) Empty if applicable

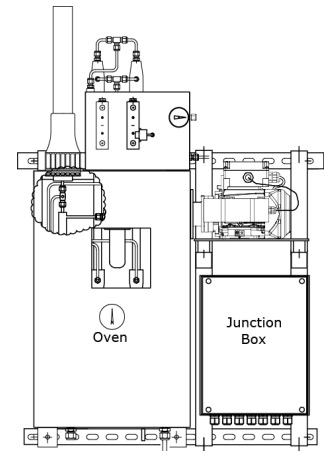

LIQUID COLLECTION TUBE

### 7.3.8 Cleaning T-union

In Sample Conditioning System, SCS:  
A clogged T-union can reduce the sample flow.

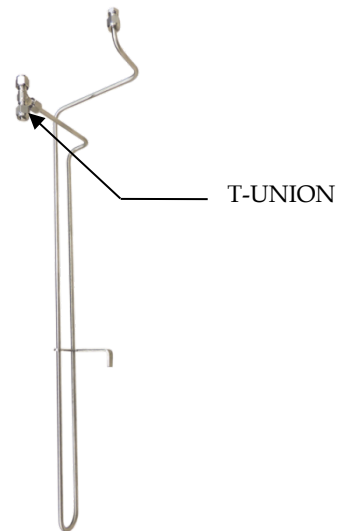
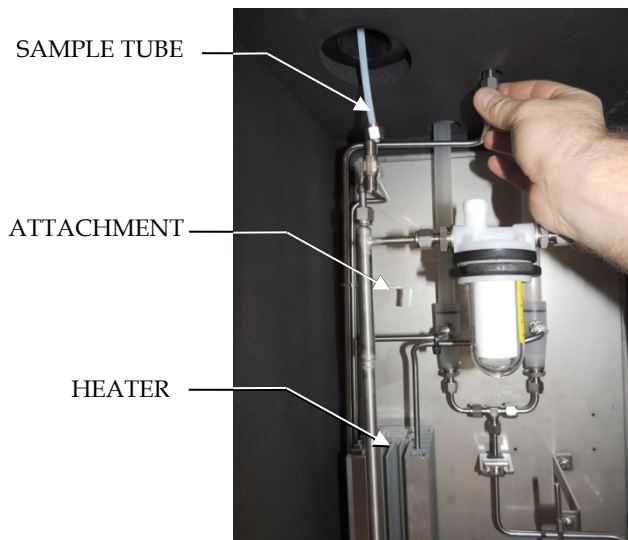

- 3) Disconnect the sample tube from the T-union.
- 4) Use adjustable spanner and combination spanner 14 mm and disconnect the T-union.
- 5) Check for trail of oil and water.
- 6) Clean the T-union.
- 7) Connect the T-union and the sample tube.

### 7.3.9 Replacing dryer tubes (sample gas dryer)

In Sample Conditioning System, SCS:



---

**Caution** *Dryer tubes are modified to fit ShipCEMS. Always order dryer tubes from Norsk Analyse.*

---

**Part no: 122235**

- 1) Moisture alarm can also be activated, when dryer tubes are worn.
- 2) Turn off main fuse in SCS cabinet junction box.
- 3) Replace dryer tubes by disconnecting fittings on upper and lower dryer tube holder.

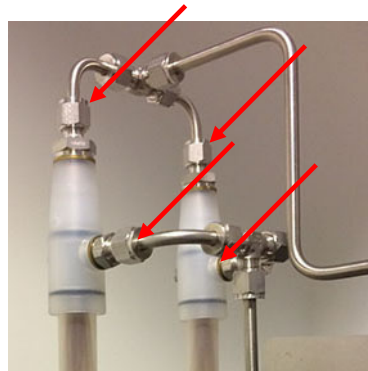
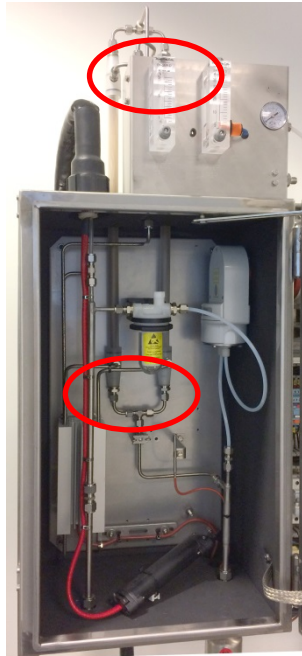

- 4) Remove the set screw on upper dryer tube holders (located on top of the cabinet).

*Note Removing the old dryer tube holders need not extra care. BUT! Removing holder on the new dryer tubes require extra care! If not, the delicate element inside can be broken and otherwise destroyed!*

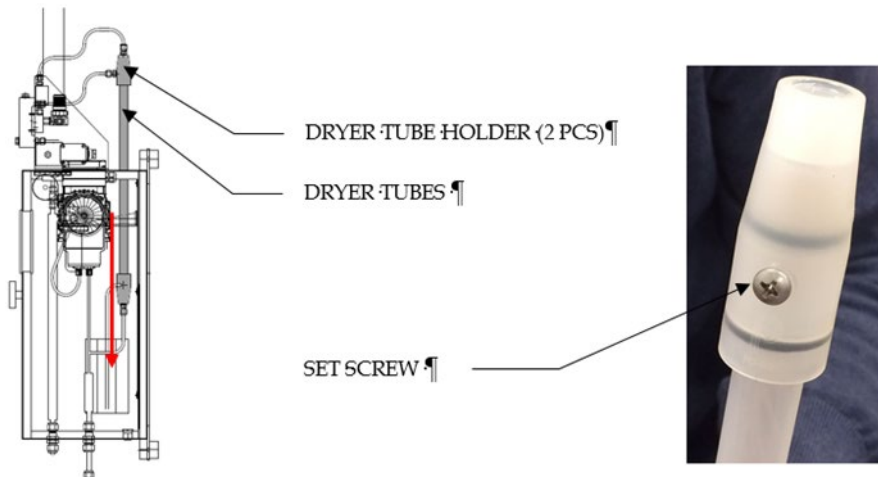

- 5) Loosen the top nut on cable gland.
- 6) Push the dryer tubes through the cable glands into the cabinet.



**Mounting new dryer tubes:**

- 7) Important! Carefully remove the top dryer tube holders on the two new dryer tubes (otherwise they cannot enter the cable gland). **DO NOT PULL!** Remove by pushing a blunt object (e.g. pen) through the holder and thereby pushing the tube from the holder.
- 8) Enter through the cable glands and install the new dryer tubes in reverse order.
- 9) Perform flow adjustment once dryer tubes are installed. Refer to 5.3.1.1 or 5.3.1.2.



### 7.3.10 Particle filter in air filter unit

**Part no: 122233**

The filter is mounted under the analyser cabinet. Refer to Figure 14.

Refer to chapter 7.2 for maintenance schedule.

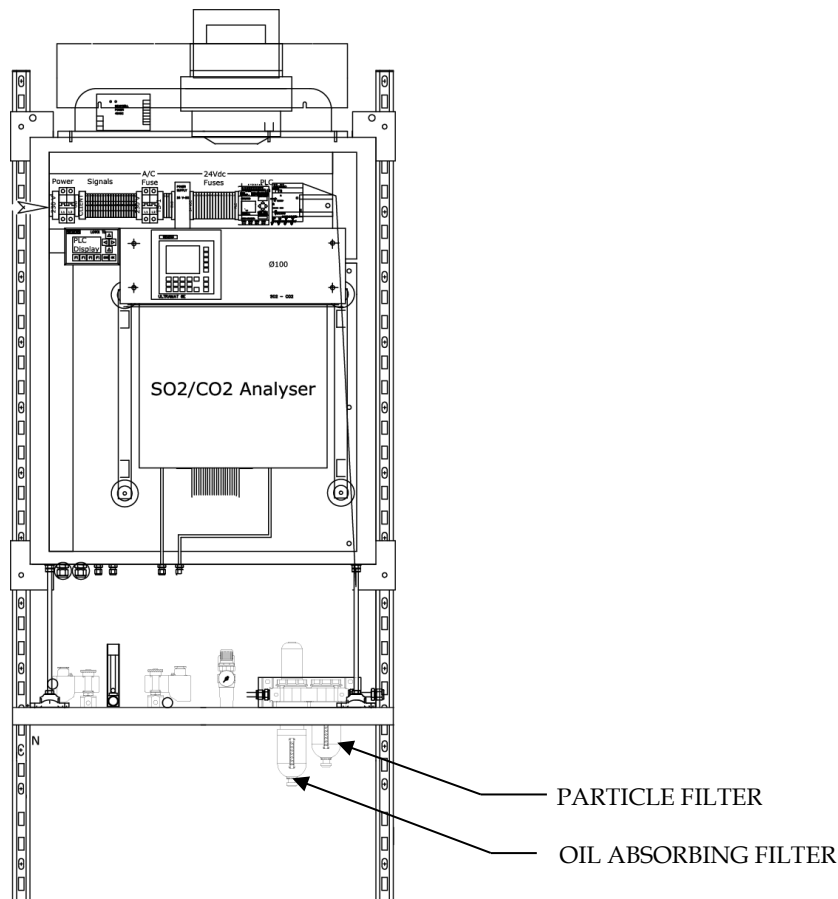

Figure 14 Particle and oil absorbing filter on filter unit

### 7.3.11 Oil absorbing filter in air filter unit

**Part no: 122234**

The filter is mounted under the analyser cabinet. Refer to Figure 14.

Refer to chapter 7.2 for maintenance schedule.

### 7.3.12 Replace condense trap

**Part no: 128732**

The condense trap is located inside the analyser cabinet.  
The function of the trap is to protect the analyser from moisture by removing any moisture that might have passed the sample conditioning phase.



ANALYSER CABINET

1) Press F4 on LOGO display and select “Air inlet open”.

2) Assemble the filter unit and tighten the connections.

For later maintenance:  
Write current date on the yellow label.  
Leave the label on the filter.



3) Make sure the yellow label on the filter unit is facing upwards.

Install the filter unit, starting with the top.

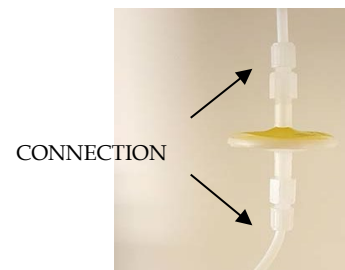

4) Tighten the connections and make sure that the filter unit is somewhat vertical.

5) Perform a flow adjustment according to chapter 5.3.1 before any sampling or calibration.

### 7.3.13 Replace demister filling - only demister quills

**Part no:** 129961 ShipCEMS - Demister Filling (3 pcs.) for 25 mm quills  
134087 (ShipCEMS - Demister filling Hastelloy C (3 pcs.) for 36 mm quills

Request the following data sheet for guidance.

→ NA-E-DSH-083 NA ShipCEMS Sample Quill Selection Chart

This is only applicable if a demister quill is installed. The standard quill does not need demister filling. Refer to figure in chapter 3.2.

After a year approximately the demister filling is used up. Replace more often if there is no filling at all left when replacing.

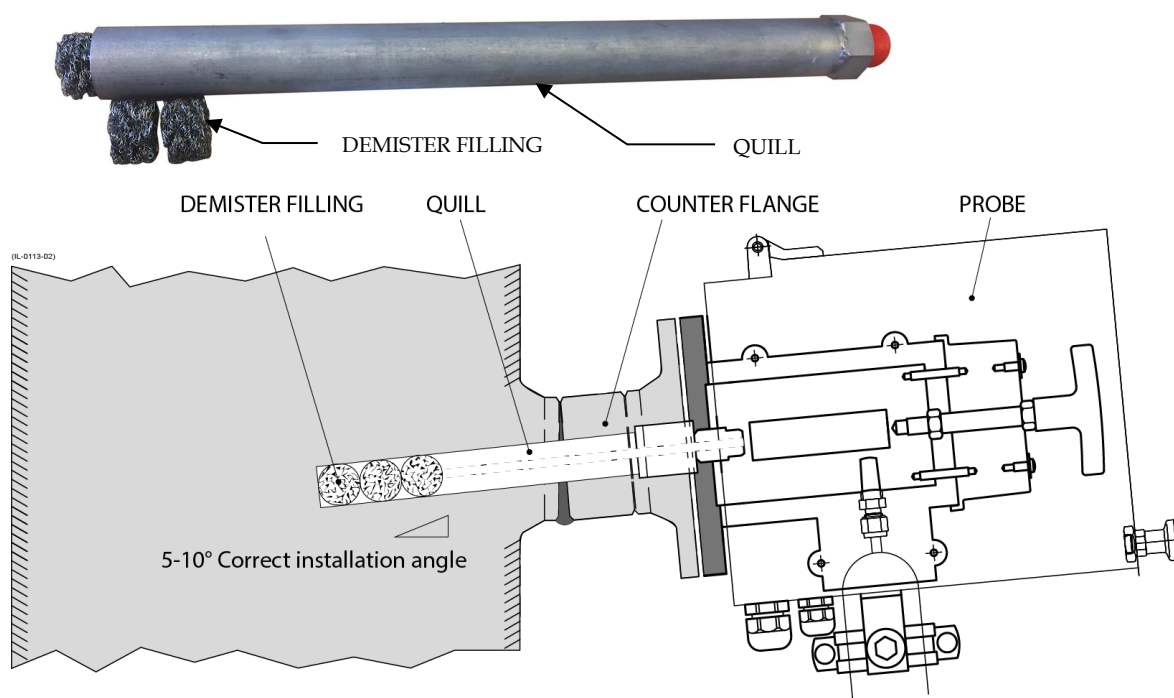

- 1) Detach the heated sample line from the probe.
- 2) Disconnect the probe from the flange using the four screws.
- 3) Pull the probe and the whole quill from the funnel.
- 4) Replace/insert new demister filling, one or all three "cushions".  
The filling should be in the tip of the quill and no distance between.
- 5) Remount the probe and heated sample line in reverse order.

### 7.3.14 Cleaning heated sample line

The tube inside the heated sample line can get dirty. If a flow alarm occurs and the sample line is clogged, there are two ways to solve the problem:

- Clean the sample tube that is connected.
- Connect to the spare sample tube.

#### 7.3.14.1 Clean the sample tube

- 1) Disconnect the sample line in the T-piece in the SCS. Refer to Figure 7 on 33.
- 2) Remove the mounting bracket on probe.
- 3) Disconnect sample tube from the sample outlet of the probe at the fitting.
- 4) Start from the SCS and use instrument air to clean the tube.
- 5) Connect sample line in both ends.

#### 7.3.14.2 Connect to the spare sample tube

---

*Note*                      *Make sure fittings are available.*

---

- 1) Refer to installation manual chapter *Installation procedures*.
- 2) Remove the mounting bracket on probe.
- 3) Disconnect the sample tube from the sample outlet of the probe at the fitting.
- 4) Seal the old sample tube in both ends.
- 5) Connect spare sample tube to the sample outlet of the probe using new fitting.
- 6) Mount the mounting bracket.
- 7) In the SCS; switch to the spare sample tube using new fitting.

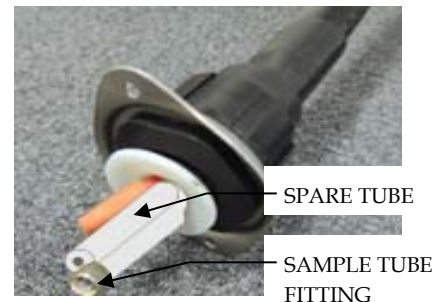

### 7.3.15 Leak test

#### 7.3.15.1 Entire sample line

---

*Note* Perform test on each stream. Contact Norsk Analyse for further instructions.

*Note* We recommend Norsk Analyse personnel to perform leak test during annual service.

---

#### 7.3.15.2 SCS

---

*Note* Perform test on each SCS.

---

- 1) Block sample outlet on the SCS.
- 2) Make sure that back-purge solenoid valve is closed (deactivated).
- 3) Read and print down the set flow:  
..... (l/min)
- 4) Adjust flowmeter for recycle air to maximum flow.  
Read and print down the recirculated flow:  
..... (>4.0 l/min)
- 5) This is a measure of pump capacity in correlation to what it should be and that there is no leakage on the push side of the pump.
- 6) Reset the flow to value in step 3).

### 7.3.16 Cleaning of analyser module

#### **Exterior:**

The front panels and doors can be washed. Clean using a sponge or cloth soaked in water contained cleansing agent. The surface of the display area in particular must only be cleaned using a slight pressure to prevent damage to the thin foil. Make sure that no water enters the analyser when cleaning.

#### **Interior:**

If necessary, the inside can be carefully blown out using instrument air gun after opening up the analyser.

#### 7.3.16.1 HOTSWAP - quick change of analyser module

In case of defect analyser module, Norsk Analyse has a hotswap program to minimise the down period. Contact Norsk Analyse service department. A new analyser module together with a step-by step instruction will be sent within days. The old analyser is then returned to Norsk Analyse.

### 7.3.17 Service air dryer

The air dryer is optional.

- Every 12,000 hrs or 24 months.
- Every 24,000 hrs or 48 months.

Request service kit and service instructions (*NA-E-INS-079 ShipCEMS Optional Air Dryer Maintenance Instructions*).

The optional air dryer needs to be serviced according to table:



Streams	Interval	Part no.
1-2 streams	2-years kit	129792
1-2 streams	4-years kit	134827
3-4 streams	2-years kit	129794
3-4 streams	4-years kit	134831

### 7.3.18 Replace air cooler fan

**Caution** *Neglect to turn off cabinet and replace air cooler unit can seriously damage the analyser module!*

Air cooler Part no: [116603]  
 Internal fan Part no: [134971]  
 External fan Part no: TBA.

If the fans in the air cooler unit does not work; follow the procedure;

- 1) Turn immediately off the analyser cabinet using main fuse.

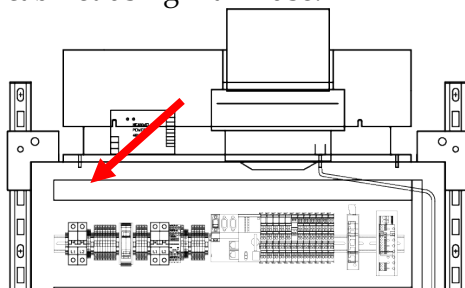

- 2) Request instruction and change fan/fans.
- 3) Turn on main fuse.

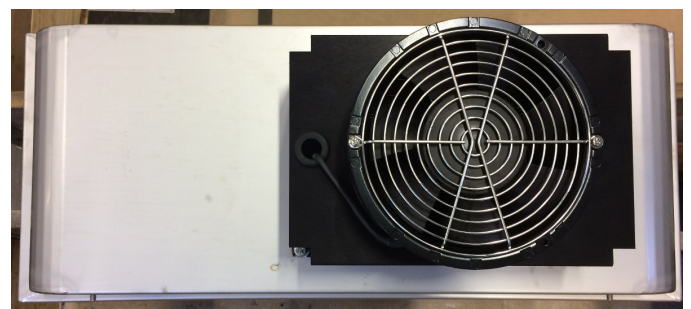

### 7.3.19 Clean the heatsinks with compressed air

Dust and dirt accumulate on the heatsinks in the air cooler.

- 1) Turn immediately off the analyser cabinet using main fuse. Refer to picture in previous chapter.
- 2) Disconnect the white cable and the drain hose.

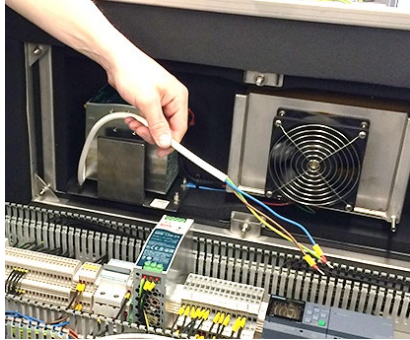

- 3) Remove the top by removing 4x fasteners.

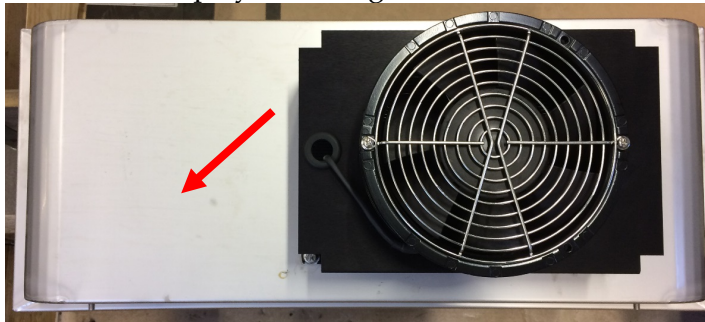

- 4) Place the unit upside down on a table.

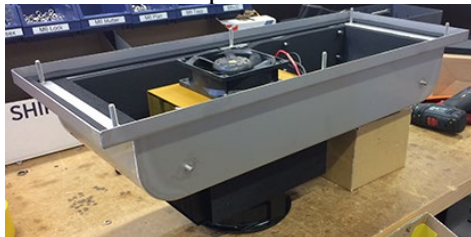

- 5) Remove the air cooler and rinse the heatsinks with compressed air.

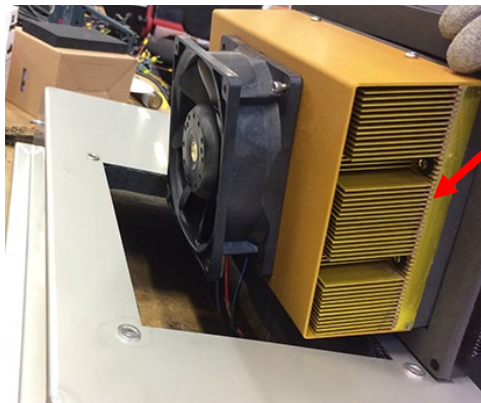







- 6) Remount the assembly in reverse order.

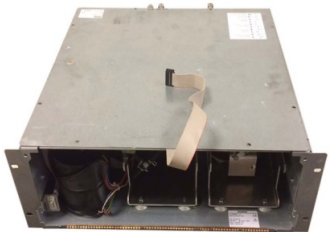



# 8 Spare parts lists



## 8.1 Analyser system





Note that item numbers refer to general arrangement drawing [1002] and [1802].



Item no.	Description	Part no.	
Drawings [1003]			
1	ShipCEMS - Analyser hotswap 110VAC ShipCEMS - Analyser hotswap 230VAC	129748 125239	
N/A	<ul style="list-style-type: none"> <li>ShipCEMS AM 230V fuse, 1A - 250 V (10ea) (120V)</li> </ul>	123581  (122225)	
2	ShipCEMS AC Main Automatic fuse 10A	125198	



Item no.	Description	Part no.	
3	ShipCEMS Automatic fuse A/C 6A	124744	
5	ShipCEMS LOGO Power supply (24V) (same for LOGO TD and LOGO TDE)	123526	
6	ShipCEMS Cooler Power supply (48V)	123525	
7	<p>ShipCEMS Cooler Unit</p> <p>Parts inside:                      Air cooler Part no: [116603]                      Internal fan Part no: [134971]                      External fan Part no: TBA.</p>	125689	

Item no.	Description	Part no.	
8	ShipCEMS LOGO8 TDE complete with firmware	125942	
9	ShipCEMS Clean Air Filter	120404	
9.2	<ul style="list-style-type: none"> <li>ShipCEMS AF Particle Filter Kit</li> </ul>	122233	
9.1	<ul style="list-style-type: none"> <li>ShipCEMS AF Oil Absorber Filter Kit</li> </ul>	122234	

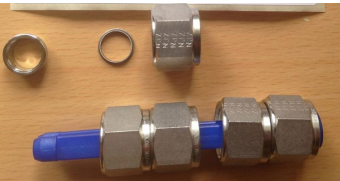
Item no.	Description	Part no.	
10	ShipCEMS Air Reduction Regulator	125423	 <p>A photograph of an air reduction regulator. It features a black top handle, a circular pressure gauge with a white face and black markings, and a clear cylindrical body with a white internal piston. The device is mounted on a wooden surface.</p>
11	ShipCEMS sample /calibration solenoid valve 2/2-24V	122232	 <p>A photograph of a solenoid valve. It has a black rectangular solenoid coil on top of a silver metal body. Two red-handled ports are visible on the side. The valve is shown next to its packaging, which includes a label with part number 122232 and description 'ShipCEMS reservoir solenoid valve 2/2-24VDC'.</p>
12	ShipCEMS sample flow indicator	122231	 <p>A photograph of a flow indicator. It is a clear plastic graduated cylinder with a white scale and a white piston. The scale is marked from 1 to 7 NL/min air. The device is shown next to its packaging, which includes a label with part number 122231 and description 'ShipCEMS sample flow indicator 0.5-7 NL/min'.</p>



Item no.	Description	Part no.	
13	ShipCEMS stream select solenoid valve 3/2-24V	122230	 <p>A photograph of a black solenoid valve with a stainless steel body and various ports. A white label is attached to the top, featuring a barcode and the following text: 'Artikelnr. 122230', 'Stückzahl 500824 (AC-14)', 'Varenavn ShipCEMS stream select solenoid valve 3/2-24VDC'.</p>
15	ShipCEMS (AC) fuse 2A - 250 V (10ea)	123572	 <p>A photograph of ten small, cylindrical fuses in their original packaging. A white label is attached to the front, featuring a barcode and the following text: 'Artikelnr. 123572', 'Stückzahl 500966 (AC-24)', 'Varenavn ShipCEMS (AC) fuse 2A - 250 V (10ea)'.</p>
(16)	ShipCEMS Interface Unit (optional)	125704	 <p>A photograph of a white electronic interface unit with a dense array of multi-colored connectors and cables plugged into it.</p>
N/A	ShipCEMS Back-purge kit	120037	 <p>A photograph of various components for a back-purge kit, including a long metal tube, a black cable, a blue connector, and several small metal fittings and tools.</p>
17	Analyser condense trap w/adapter	128732	 <p>A photograph of a white plastic condense trap with a white adapter. A white label is attached to the top, featuring a barcode and the following text: 'Artikelnr. 128732', 'Stückzahl 501288 (AC-27)', 'Varenavn ShipCEMS Analyser condensate trap'.</p>

Item no.	Description	Part no.		
N/A	ShipCEMS - Air Dryer Service kits	Se table	 	
	Streams	Interval		Part no.
	1-2 streams	2-years kit		129792
	1-2 streams	4-years kit		134827
	3-4 streams	2-years kit		129794
3-4 streams	4-years kit	134831		
N/A	ShipCEMS - 6 mm Nuts & Ferrule Connect. (10 ea)	123512		
N/A	ShipCEMS - 10mm Nuts & Ferrule Connect. (5 ea)	123513		
N/A	ShipCEMS - AM pressure switch	122228		
N/A	ShipCEMS - AC cabinet temp. Thermostat	125691		



Item no.	Description	Part no.	
N/A	ShipCEMS - Damper Analyse Module	125698	 4 X
4	ShipCEMS - Pressure relief valve	127346	

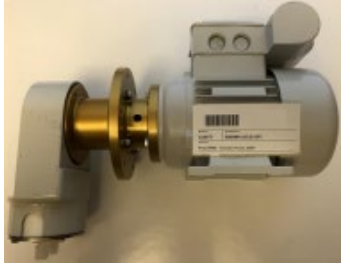

## 8.2 Sample conditioning system, SCS



Note that item numbers refer to general arrangement drawings [1801] and [1802].

Item no.	Description	Part no.	
Drawings [1801]			
19	ShipCEMS sample gas dryer	122235	
20	ShipCEMS sample shut off solenoid valve 2/2-230V (120V)	122236 (127594)	
22	ShipCEMS Sample pump 230V (120V)	123977 (124901)	

Item no.	Description	Part no.	
N/A	Pump - Bellow PTFE with set screw.	122244	
25	ShipCEMS Temp. Gauge door	125697	
21	ShipCEMS sample gas filter, package (5ea)	133615	
23	ShipCEMS - Sample flow indicator with alarm 2-36 NL/min	122238	
24	ShipCEMS - Bypass flow indicator 1-9 NL/min	122239	





Item no.	Description	Part no.	
26	ShipCEMS - Pressure regulator - Dryer air (0-10bar)	125690	
27	ShipCEMS - Moisture Sensor	123515	
N/A	ShipCEMS - Flow alarm transmitter	122932	
Drawings [1802]			
28	ShipCEMS - 500W Heater SCS	131628	

Item no.	Description	Part no.	
29	ShipCEMS - Temperature element	131627	
31	ShipCEMS - Pump maintenance kit	122242	
32	ShipCEMS Relay 5A (R1 / R2) 230 V (120V)	122241 (127598)	
34	ShipCEMS - SCS Flow alarm Controller 230V	125694	

Item no.	Description	Part no.	
35	ShipCEMS - SCS Temp. Controller incl.display (w.Program)	125693	
36	ShipCEMS - Controller moisture detector	124900	



### 8.3 Sample probe

Refer to general arrangement drawing [1202].

Item no.	Description	Part no.	
N/A	ShipCEMS sample probe filter element	122247	
A	ShipCEMS - Sample probe quill, SS316 L=1000mm (Ø12mm)	122246	
B	ShipCEMS - Sample probe quill Hastelloy L=1000mm (Ø12mm)	123979	
C	ShipCEMS - Sample probe quill, Hastelloy L = 500 mm (Ø12mm)	122248	
D	ShipCEMS - Sample probe quill w. demister Hastelloy L=500mm (Ø25mm)	129965	

Item no.	Description	Part no.	
E	ShipCEMS - Sample probe quill w. demister Hastelloy L=1000mm (Ø25mm)	135020	
F	ShipCEMS - Sample probe quill w. demister SS316Ti L=500mm (Ø36mm)	129964	
	ShipCEMS - Demister filling Hastelloy C (3 pcs.) (filling for 129965 and 135020)	134087	
N/A	ShipCEMS - Demister Filling (3 pcs.) (filling for 129964)	129961	
N/A	ShipCEMS - Probe Cap for termination (HOT)	129544	
N/A	ShipCEMS - Flange Gasket	133946	
N/A	ShipCEMS - SP temperature switch	122249	

## 8.4 Calibration gas

Item no.	Description	Part no.	
N/A	ShipCEMS-Cal. gas 40ppm SO <sub>2</sub> , 8%CO <sub>2</sub> 10L. incl. box	125621	
N/A	ShipCEMS - Calibration gas SO <sub>2</sub> 160ppm / CO <sub>2</sub> 8% 10L 36M	135030	
N/A	ShipCEMS - Calibration gas SO <sub>2</sub> 160ppm / CO <sub>2</sub> 12% 10L 36M	135142	

# 9 Technical specifications

## 9.1 Environmental requirements

ShipCEMS is designed to comply with:

- IACS E10 - Test Specification for Type Approval
- IEC 60945 - Maritime navigation and radio communication equipment and systems – General requirements – Methods of testing and required test results
- IEC 60529 - Degrees of Protection Provided by Enclosures (IP Code)

## 9.2 Type approvals

ShipCEMS is designed in accordance with the requirements of:

- DNV GL (Certificate no. TAA0000107)
- Lloyd's Register (Certificate no. TA19/20023)
- Bureau Veritas (Certificate no. 42658/A0 BV)
- ABS (Certificate no. 15-HS1356772-PDA)
- Rina Services (Certificate no. MAC085618XG)
- Class NK (Certificate no. TA18198M)
- KRS Pending (Certificate no. CPH39948-AC001)
- CCS Pending (Certificate no. GB19PTB00008)

## 9.3 Measuring range

Item	Specification
SO <sub>2</sub>	0.1% Sulphur cap: 0-50 ppm 0.5% Sulphur cap: 0-200 ppm (0-50 ppm to 0-1000 ppm)
CO <sub>2</sub>	0-10 mol% (0-5 mol% to 0-15 mol%)
Others on request	

## 9.4 Physical dimensions

Item	Specification
Analyser system cabinet Dimensions (WxDxH) Weight	800 x 400 x 1000 mm (31 ½" x 15 ¾" x 39 ½") 143 kg (315 lbs.)
Sample conditioning system cabinet Dimensions (WxDxH) Weight	400 x 300 x 700 mm (15 ¾" x 12" x 27 ½") 52 kg (115 lbs.)
Heated sample probe Probe length Quill length Flange diameter Weight	254 mm (10") 1 m (40") 160 mm (DIN DN 65 PN 6) 10 kg (22 lbs.)
Sample probe counter flange Dimensions	DIN flange DN 65, PN 6, or JIS flange 10K DN65 (or other customer specific)
Heated sample line (wet) Diameter Weight	37 mm (1 7/16") 1.2 kg/m (0.4 lbs./ft)

## 9.5 Materials

Item	Specification
Cabinets	SS316L
Tubing	PFA/PTFE
Fittings	SS316L
Heated sample probe quill	SS316L
Heated sample probe counter flange	SS316L (or customer specific)

## 9.6 Ingress protection

- IP44

## 9.7 Maximum temperature SCS and AC

The maximum ambient temperature in sample conditioning cabinet and analyser cabinet is 55°C.

## 9.8 Power supply

Item	Specification
Power from ship switchboard	230V, 2-phase, 50/60 Hz Option: 110V, 2-phase, 50/60 Hz
Power cable specifications	230V: 2 x 2.5 mm <sup>2</sup> + PE 110V: 2 x 4 mm <sup>2</sup> + PE

## 9.9 Power consumption

Item	Specification
Analyser cabinet	590 W
Sample conditioning system	690W
Heated sample probe	350 W
Heated sample line (wet)	67 W/m
Sample line (dry)	Non heated if ambient temperature > +5°C 15 W/m if ambient temperature < +5°C

## 9.10 Calibration gas (span)

Item	Specification
Gas composition <i>Standard specifications. Other gas compositions may be ordered on request.</i>	40 ppm SO <sub>2</sub> 8 mol% CO <sub>2</sub> Rest Nitrogen N <sub>2</sub>  Or  160 ppm SO <sub>2</sub> 8 mol% CO <sub>2</sub> Rest Nitrogen N <sub>2</sub>  Or  160 ppm SO <sub>2</sub> 12 mol% CO <sub>2</sub> Rest Nitrogen N <sub>2</sub>
Cylinder size	10 litre (typical)
Cylinder pressure	> 100 barg (> 1500 psig)
Consumption	5 litre / min / calibration

## 9.11 Instrument air

Item	Specification
Quality	Dry, oil-free according to <b>ISO 8573-1:2010 class 4.3.4</b>  Dew point: ≤ -17°C Particles per m <sup>3</sup> (1-5µm): ≤ 10 Total oil: 0.01 mg/m <sup>3</sup>
Consumption for each connected SCS (1 to max 4)	Minimum 15 NI/min (0.9 Nm <sup>3</sup> /hour) @ atmospheric pressure
Pressure range	6 to 8 barg (90 to 120 psig)
Dew point	<+3°C @ 8 barg minimum outlet pressure (lower than -17°C @ atmospheric pressure)

# 10 Drawing references

The ShipCEMS drawings given below are enclosed as separate files.

Note that [nnnn] is used as number identification for standard product drawings, but this is subject to change when specified by contract.

DWG	Description	ShipCEMS standard (230V)	Other options	120V
<b>Mechanical drawings:</b>				
1001	GENERAL ARRANGEMENT DRAWING ANALYSER CABINET (AC) EXTERNAL VIEW - STANDARD	X		X
1003	GENERAL ARRANGEMENT DRAWING ANALYSER CABINET (AC) INTERNAL VIEW - STANDARD	X		X
1202	GENERAL ARRANGEMENT DRAWING SAMPLE PROBE (SP)	X		X
1801	GENERAL ARRANGEMENT DRAWING SAMPLE CONDITIONING SYSTEM EXTERNAL VIEW, HOOK UP DETAILS	X		X
1901	GENERAL ARRANGEMENT DRAWING EMERGENCY STOP, OPTIONAL		X	
1903	GENERAL ARRANGEMENT DRAWING GAS DRYER, OPTIONAL		X	
<b>System drawings:</b>				
3001	SYSTEM DIAGRAM ANALYSER CABINET (AC)	X		X
3002	SYSTEM DIAGRAM SAMPLE CONDITIONING SYSTEM (SCS)	X		X
3003	SYSTEM DIAGRAM ANALYSER CABINET (AC) GAS DRYER, OPTIONAL		X	

DWG	Description	ShipCEMS standard (230V)	Other options	120V
<b>Electrical drawings:</b>				
5001	TERMINATION DRAWING - OVERVIEW ShipCEMS SYSTEM 230VAC STANDARD	X		X
5002	TERMINATION DIAGRAM 230VAC & 24/48DC POWER DISTRIBUTION ANALYSER CABINET (AC)	X		X
5003	TERMINATION DIAGRAM SIGNAL DISTRIBUTION / INTERFACE ANALYSER CABINET (AC)	X		X
5004	TERMINATION DIAGRAM SAMPLE CONDITIONING SYSTEM (SCS)	X		X
5005	TERMINATION DIAGRAM SAMPLE PROBE (SP)	X		X
<b>Block diagrams:</b>				
6001	SYSTEM BLOCK DIAGRAM P&ID DISTRIBUTION OVERVIEW	X		X
6002	SYSTEM BLOCK DIAGRAM SIGNAL AND POWER DISTRIBUTION OVERVIEW	X		X



© Norsk Analyse

